

Déjà-vu — design Naoto Fukasawa, 2007



Sometimes normality can be the fruit of a lengthy process of study and refining. This is what happened in the case of Déjà-Vu, a stool whose forms give a reassuring sense of familiarity, inspired as they are by the classic wooden stool, but actually produced using a D-shaped extruded aluminium profile. This solution was devised by designer Naoto Fukasawa together with Magis, to create a versatile, light and durable item of furniture. Available in three finishes (polished or black

or white painted aluminium) and in three different heights, ready to meet the endless different requirements of the living, office and contract worlds, Déjà-vu does not demand a constant place in the limelight, and yet its discreet presence is always appreciated, be it alone or together with the seat and table from the same family.



Designer in Magis

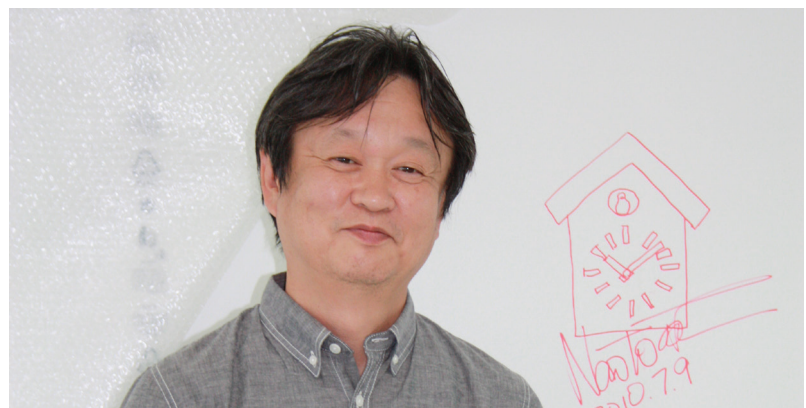

Déjà-vu — design Naoto Fukasawa, 2007
Technical Sheet

Tables

Material: legs in extruded aluminium polished or painted. Tops in HPL.

Magis logo is stamped on each product of our collection vouching for their originality.

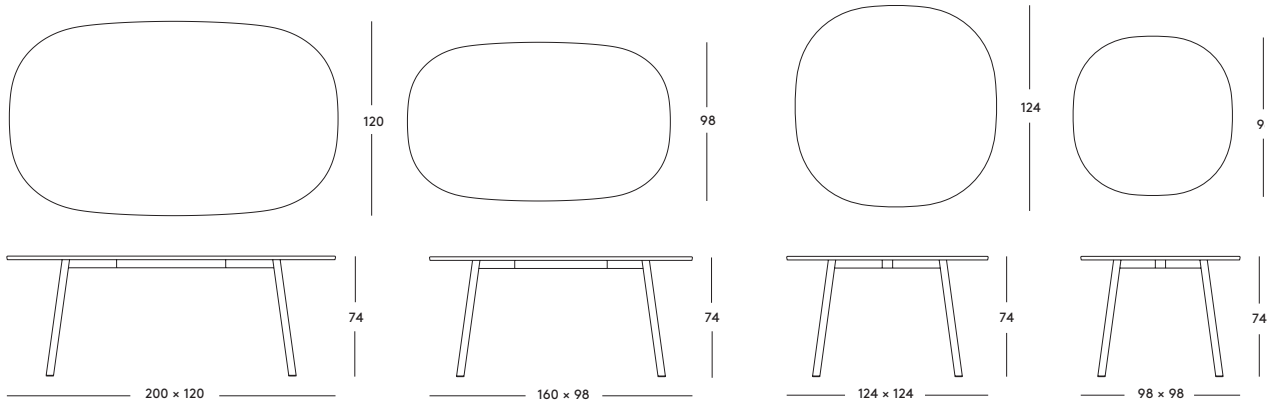

Finish
Frame: Polished Aluminium
Top: White 8500

Finish
Frame: Black 5130
Top: Black 8510

FATIGUE, LOAD AND IMPACT TESTS

ANSI/BIFMA X5.5-2008



magisdesign.com

The information included in this product sheet are based on the last data in our current pricelist. Magis reserves the right to modify the products without notice.

Designer



Naoto Fukasawa

To design shape is to give form to values that people tacitly share and wish for. Naoto Fukasawa visually captures these values and draws their exact outline. His ability to visualize the unseen outlines of things is not easily worded and described, nonetheless, people are immediately convinced of his ability when they experience his design.

Fukasawa's notions and expressions in approaching the essential values of things through design transcend borders and domains, and his thoughts are well respected internationally.

