

# MY

22

TABLES

 *friulsedie*  
MADE IN ITALY



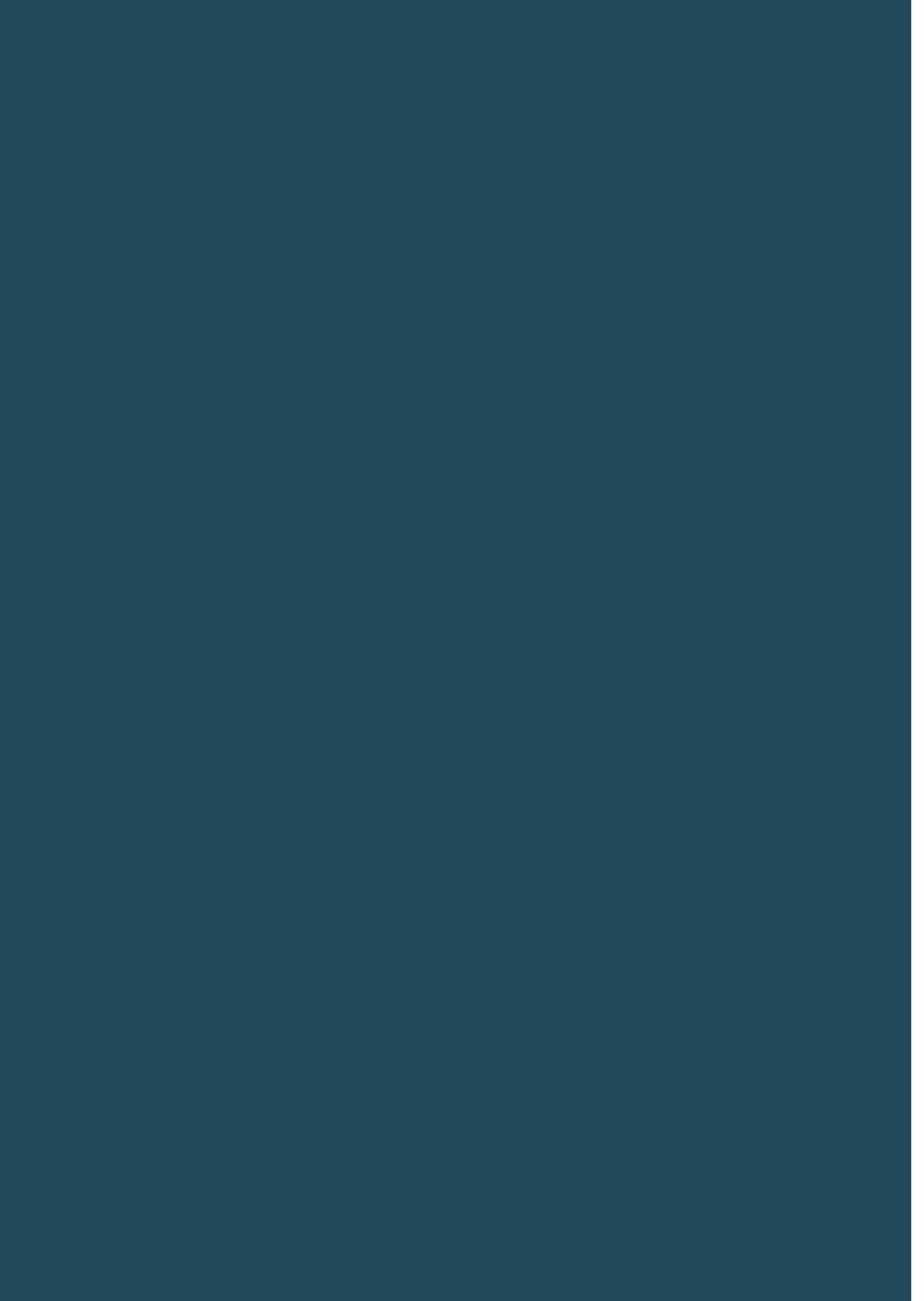

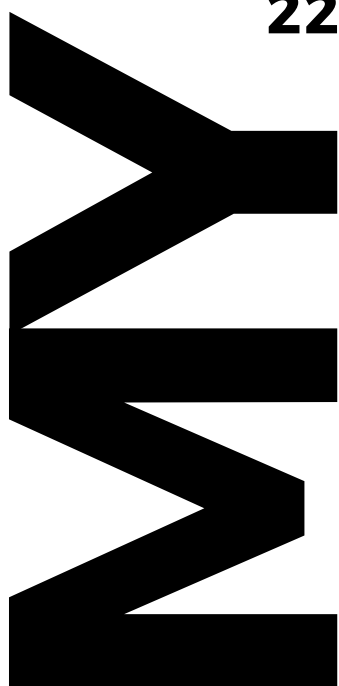

## TABLES

***Dedichiamo questo lavoro a Giuliano Dalmasson, nostro riferimento e guida negli anni.***

***Proseguiamo il cammino che ha tracciato, con la sua stessa visione concreta e ottimista.***



*We dedicate this work to Giuliano Dalmasson, our reference and guide over the years.*

*We follow his path, with the same pragmatism and optimism.*





# Tutto quello che trovate in ciascun prodotto Friulsedie arriva da lontano.

TUTTO QUELLO CHE TROVATE IN CIASCUN PRODOTTO FRIULSEDIE ARRIVA DA LONTANO. NEL TEMPO, PERCHÉ L'AZIENDA HA UNA STORIA ULTRACENTENARIA NEL SETTORE DEL DESIGN E PRODUZIONE DI ARREDAMENTI. NELLO SPAZIO, PERCHÉ LE PRIME CREAZIONI DI FRIULSEDIE HANNO VISTO LA LUCE IN UN CONTESTO CHE, PARTITO DAL CUORE DEL FRIULI, HA PORTATO NEL MONDO INTERO L'ARTE DI REINVENTARE L'OGGETTO-SEDIA, PER ESTENDERE POI LA MEDESIMA ATTENZIONE AL SUO NATURALE COMPLEMENTO: IL TAVOLO. OGGI FRIULSEDIE È UNA REALTÀ AZIENDALE CONSOLIDATA CHE PROGETTA E PRODUCE AUTONOMAMENTE INTERE COLLEZIONI DI TAVOLI, SEDIE E SGABELLI DI DESIGN E ALTISSIMA QUALITÀ, PROPONENDO MAGNIFICHE POSSIBILITÀ DI PERSONALIZZAZIONE, CURANDO OGNI MOMENTO DEL PROCESSO PRODUTTIVO: DAL CONCEPT ALLA SELEZIONE DEI MATERIALI, CON UN IMPORTANTE RIGUARDO PER L'IMPRONTA AMBIENTALE DI TUTTO IL CICLO VITALE DEI PROPRI ARTICOLI. LA COMPLESSITÀ DEL CONTEMPORANEO È IL PERNO DEL NOSTRO LAVORO. ABBIAMO UNA PASSIONE PER LA COSTANTE RICERCA DI NUOVE TECNOLOGIE CHE POSSANO RENDERE SEMPRE PIÙ CONFORTEVOLE E AGILE IL VIVERE QUOTIDIANO, E LA RACCONTIAMO NON SOLO ATTRAVERSO LE SCELTE DI PRODUZIONE, MA ANCHE CON UNA RINNOVATA CURA DEL SERVIZIO DI VENDITA E ASSISTENZA AI NOSTRI CLIENTI. PERCHÉ IL VOSTRO TEMPO È UN BENE PREZIOSO E PER NOI ANCHE QUESTO È UN VALORE DA PRESERVARE. TUTTO QUELLO CHE TROVATE IN CIASCUN PRODOTTO FRIULSEDIE, APPUNTO, ARRIVA DA LONTANO. PER ESSERVI MOLTO VICINO OGNI VOLTA CHE DESIDERATE.

EVERYTHING YOU FIND IN EACH FRIULSEDIE PRODUCT COMES FROM AFAR. FAR IN TIME, BECAUSE OUR COMPANY HAS OVER A HUNDRED YEARS OF HISTORY IN THE DESIGN AND FURNISHING SECTOR. FAR IN SPACE, BECAUSE FRIULSEDIE FIRST CREATIONS WERE BORN IN A CONTEXT THAT, STARTING FROM THE HEART OF FRIULI, HAS BROUGHT THE ART OF REINVENTING THE OBJECT-CHAIR INTO THE WHOLE WORLD, TO THEN EXTEND THE SAME ATTENTION TO ITS NATURAL COMPLEMENT: THE TABLE. TODAY FRIULSEDIE IS A CONSOLIDATED COMPANY THAT INDEPENDENTLY DESIGNS AND PRODUCES ENTIRE COLLECTIONS OF TABLES, CHAIRS AND STOOLS OF DESIGN AND HIGH QUALITY, OFFERING INFINITE POSSIBILITIES OF CUSTOMIZATION WITH PARTICULAR ATTENTION TO EVERY PHASE OF THE PRODUCTION PROCESS: FROM THE CONCEPTION TO THE SELECTION OF MATERIALS, WITH AN IMPORTANT REGARD TO THE ENVIRONMENTAL FOOTPRINT OF THE ENTIRE LIFE CYCLE OF ITS ITEMS. THE COMPLEXITY OF THE CONTEMPORARY IS THE PIVOT OF OUR WORK. WE HAVE A PASSION FOR A CONSTANT SEARCH OF NEW TECHNOLOGIES THAT CAN MAKE DAILY LIVING MORE AND MORE COMFORTABLE AND AGILE, WHICH WE PROVE NOT ONLY THROUGH PRODUCTION CHOICES BUT ALSO WITH A RENEWED ATTENTION TO SALES AND CUSTOMER SERVICE. BECAUSE YOUR TIME IS PRECIOUS AND FOR US THIS IS A VALUE TO PRESERVE, TOO. EVERYTHING YOU FIND IN EACH FRIULSEDIE PRODUCT, IN FACT, COMES FROM AFAR. TO BE VERY CLOSE TO YOU WHENEVER YOU WANT.



## COLLEZIONE ELITE

Elite collection



**ATLANTE T70**  
pag. 54-73



**BOSTON T50**  
pag. 74-99



**COSMO T72**  
pag. 22-53



**ECLIPSE T56**  
pag. 8-21



**MIKADO T74**  
pag. 138-151



**MODUS T63**  
pag. 152-169



**OSAKA T73**  
pag. 122-137



**PORTLAND T55**  
pag. 100-121

## COLLEZIONE EXTENSA

Extensa collection



**DENVER T52**  
pag. 186-203



**LEVANTE T54**  
pag. 172-185



**MEMPHIS T51**  
pag. 218-227



**PEGASO T53**  
pag. 204-217

## COLLEZIONE INFINITY

Infinity collection



**CARTESIO T88**  
pag. 246-255



**DIAMOND T96**  
pag. 280-291



**MADISON T97**  
pag. 270-279



**MATRIX T78**  
pag. 256-269



**SPENCER T87**  
pag. 230-245



**VICTOR T86**  
pag. 292-303

## COLLEZIONE CLASS

Class collection



**GALILEO T93**  
pag. 306-323



**LEON T98**  
pag. 336-345



**ZENITH T91**  
pag. 324-335

## COLLEZIONE PLANET

Planet collection



**APOLLO T30**  
pag. 362-369



**GIOTTO T25**  
pag. 376-385



**RAFFAELLO T32**  
pag. 370-375



**SATURNO T31**  
pag. 348-355



**SIRIUS T33**  
pag. 356-361



# Il piano dell'orizzonte.

IL PIANO DELL'ORIZZONTE. SE SI PENSA A UN'IDEA DI ORIZZONTE C'È UN CHE DI IMPALPABILE, ED È SPONTANEO ALLARGARE LO SGUARDO FINO A DOVE L'OCCHIO PUÒ ARRIVARE. MA OCCORRE ANDARE OLTRE LA VISTA, PER PORTARE QUELLA STESSA IDEA IN UN AMBIENTE DEL QUOTIDIANO: IL CONCETTO DIVENTA MATERIA E SI DEVONO DEFINIRE LINEE, COLORI, MISURE. LA COLLEZIONE ELITE È UN'ESPRESSIONE DI ELEGANZA, ALTO DESIGN ED ELEMENTI DI GRANDE PREGIO. LE OLTRE DIECIMILA CONFIGURAZIONI POSSIBILI PER TAVOLI DI ELITE SI MOLTIPLICANO ULTERIORMENTE, PERCHÉ BASTA UN TOCCO LEGGERO PER ALLUNGARE IL PIANO SINO ALL'ORIZZONTE DELL'AMBIENTE, GRAZIE AI SOFISTICATI MECCANISMI DI APERTURA SYNCRO. I PIANI SUPERALLUNGABILI DI QUESTI TAVOLI ARRIVANO A MISURE CHE SEMBRANO OLTREPASSARE I LIMITI DELL'EQUILIBRIO, MENTRE LA FORZA DI CIASCUNA DELLE POSSIBILI GAMBE SORREGGE OGNI VOLTA TUTTO COME SE FOSSE LA COSA PIÙ SEMPLICE, PROPRIO COME IL MITO DI ATLANTE CHE REGGE IL MONDO. OGNI SCELTA DI QUESTA COLLEZIONE RAPPRESENTA IL MEGLIO DEL MADE IN ITALY IN ELEMENTI, MATERIALI E DESIGN. SCEGLIERE UN TAVOLO ELITE FRIULSEDIE È UN MODO PER RAPPRESENTARE UN UNIVERSO E MATERIALIZZARE UNA PERSONALISSIMA VISIONE DEL PROPRIO LIVING.

THE PLANE OF THE HORIZON. IF YOU ENVISAGE AN IDEA OF THE HORIZON THERE IS SOMETHING IMPALPABLE, AND IT IS NATURAL TO WIDEN YOUR GAZE AS FAR AS THE EYE CAN GO. BUT IT IS NECESSARY TO GO BEYOND SIGHT TO BRING THAT SAME IDEA INTO AN EVERYDAY ENVIRONMENT: THE CONCEPT BECOMES SUBSTANCE AND LINES, COLORS, AND MEASURES MUST BE DEFINED. THE ELITE COLLECTION IS AN EXPRESSION OF ELEGANCE, HIGH DESIGN AND ELEMENTS OF GREAT VALUE. MORE THAN TEN THOUSAND POSSIBLE CONFIGURATIONS FOR ELITE TABLES MULTIPLY FURTHER, AS A LIGHT TOUCH IS ENOUGH TO EXTEND THE TOP TO THE HORIZON OF THE ENVIRONMENT, THANKS TO THE SOPHISTICATED SYNCHRO-OPENING MECHANISMS. THE SUPER-EXTENDABLE TOPS OF THESE TABLES REACH SIZES THAT SEEM TO EXCEED THE BALANCE LIMIT, WHILE THE STRENGTH OF EACH OF THE POSSIBLE LEGS SUPPORTS EVERYTHING AS IF IT WAS THE SIMPLEST THING, JUST LIKE THE MYTH OF ATLAS WHO BEARS THE WORLD. EVERY CHOICE OF THIS COLLECTION REPRESENTS THE BEST OF MADE IN ITALY IN TERMS OF ELEMENTS, MATERIALS AND DESIGN. CHOOSING A FRIULSEDIE ELITE TABLE IS A WAY TO REPRESENT A UNIVERSE AND MATERIALIZE A VERY PERSONAL VISION OF ONE'S OWN LIVING.



COLLEZIONE



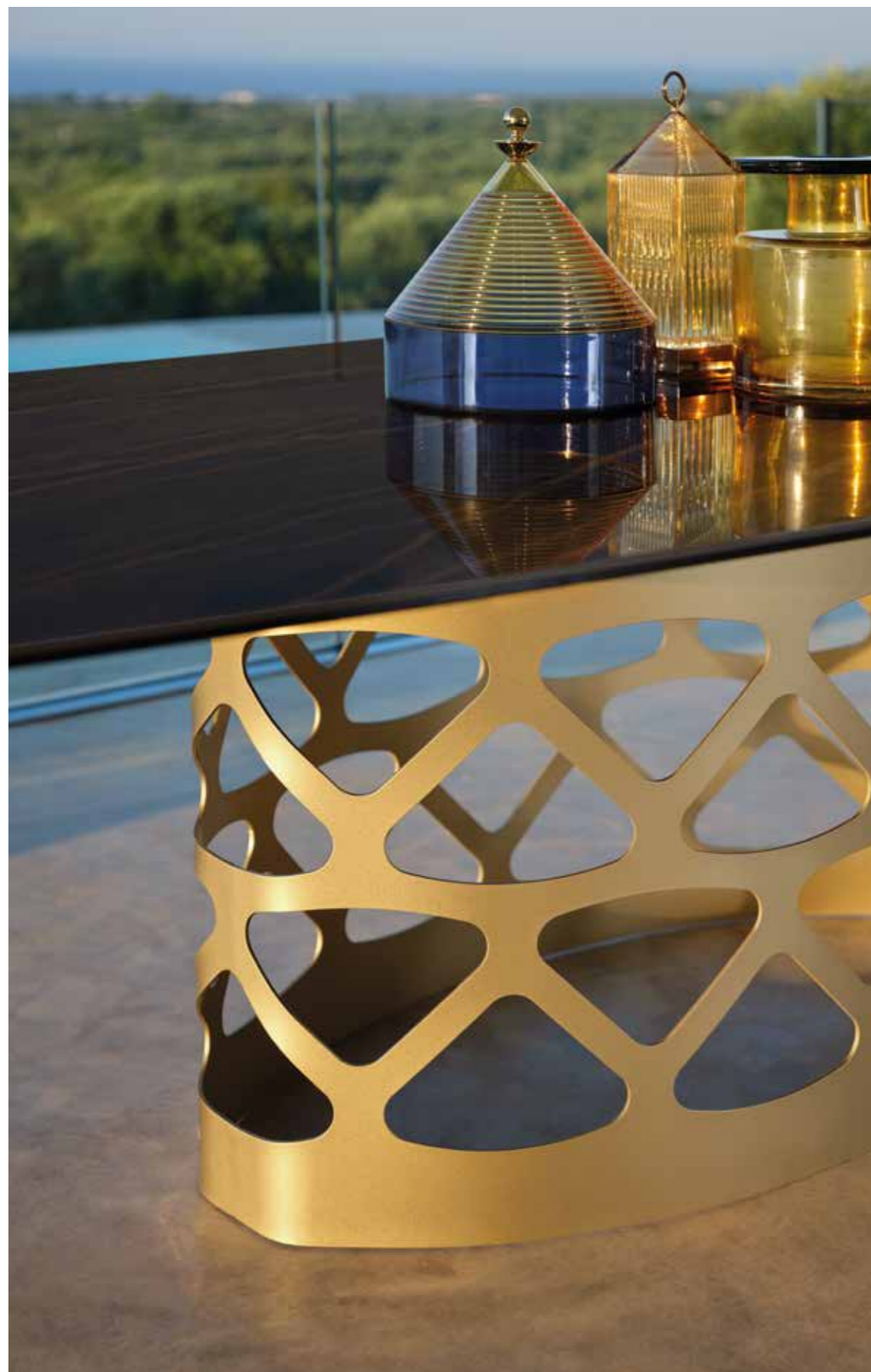

## ECLIPSE

Design Giuseppe Farinola

**Una presenza importante, quasi una corona perfetta grazie alla ricchezza della selezione di colori metallici che completano il fregio intagliato della sua base. È un tavolo concepito per suggellare lo status di un living di prestigio. I piani, di vetro o Ceramic, non fanno che esaltare ulteriormente quel magnetismo che fa di questo tavolo un unicum. Ad ECLIPSE non occorre altro che sé stesso: la sua presenza da sola rende necessari pochi altri dettagli per definire la scelta di stile.**

An important presence, almost a perfect crown thanks to the richness of the selection of metal colors that complete the carved frieze of its base. It is a table designed to seal the status of a prestigious living room. The tops, made of glass or Ceramic, enhance that magnetism that makes this table unique. ECLIPSE needs nothing but itself: its presence alone necessitates few other details to define the style choice.



## ECLIPSE T56

Tavolo Eclipse T56, fisso, metallo oro antico, piano sagomato 250x100 Ceramic Noir Desir lucido.  
Poltrona Olympia S117MC, metallo oro antico, tessuto Queens graphite.  
Eclipse table T56, fixed, antique gold metal, 250x100 glossy Noir Desir Ceramic shaped top.  
Olympia armchair S117MC, antique gold metal, graphite Queens fabric.





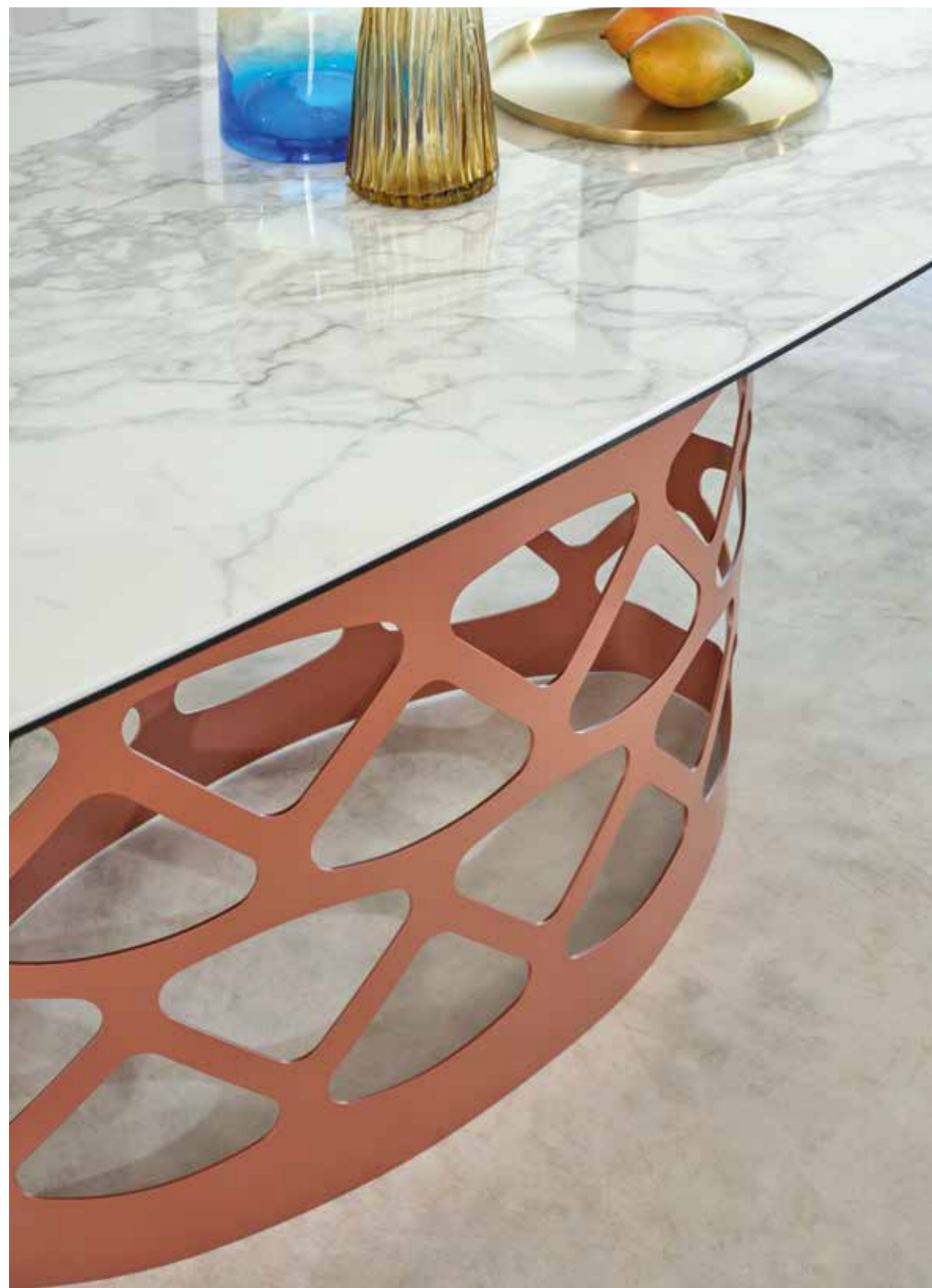

### ECLIPSE T56

Tavolo Eclipse T56, fisso, metallo oro rosa, piano sagomato 250x100 Ceramic Arabescato lucido.  
Eclipse table T56, fixed, rose gold metal, 250x100 glossy Arabesque Ceramic shaped top.

### ECLIPSE T56

Tavolo Eclipse T56, fisso, metallo oro rosa, piano sagomato 250x100 Ceramic Arabescato lucido.  
Poltrona Janis S165MC, metallo oro rosa, velluto dark blue.  
Eclipse table T56, fixed, rose gold metal, 250x100 glossy Arabesque Ceramic shaped top.  
Janis armchair S165MC, rose gold metal, dark blue velvet.







### ECLIPSE T56

Tavolo Eclipse T56, sagomato allungabile, metallo antracite, piano Ceramic Noir Desir lucido.  
Sedia Vanilla S167, metallo antracite, tessuto Victoria caramel.

Eclipse table T56, shaped extendable, anthracite metal, glossy Noir Desir Ceramic top.  
Vanilla chair S167, anthracite metal, caramel Victoria fabric.



## ECLIPSE T56

Tavolo Eclipse T56, fisso, piano sagomato 250x100 Ceramic Sahara Noir bocciardato.  
Sedia Vanilla S167, tessuto Victoria caramel, elephant, june bug, lizard green.

Eclipse table T56, fixed, 250x100 bush-hammered Sahara Noir Ceramic shaped top.  
Vanilla chair S167, caramel, elephant, june bug, lizard green Victoria fabric.





## ECLIPSE T56

Tavolo Eclipse T56, fisso, metallo ottone, piano sagomato 250x100 Ceramic Sahara Noir bocciardato.

Sedia Vanilla S167, metallo ottone, tessuto Victoria lizard green.

Eclipse table T56, fixed, brass metal, 250x100 bush-hammered Sahara Noir Ceramic shaped top.

Vanilla chair S167, brass metal, lizard green Victoria fabric.







### ECLIPSE T56

Tavolo Eclipse T56, fisso, metallo antracite, piano 250x100 Ceramic Noir Desir lucido.  
Eclipse table T56, fixed, anthracite metal, 250x100 glossy Noir Desir Ceramic shaped top.

### ECLIPSE T56

Allungabile full automatic / Full automatic extendable

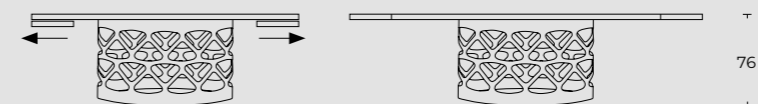

Allungabile automatico con allunghe laterali simmetriche. Piano in vetro spess. 12 mm.  
o Ceramic spess. 13 mm.

Automatically extendable with symmetrical side extensions. Glass top thk 12 mm  
or Ceramic top thk 13 mm.

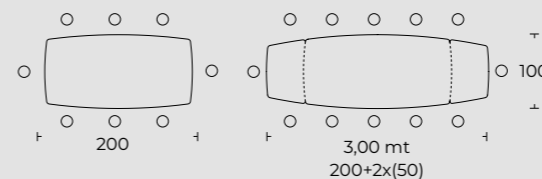

### ECLIPSE T56

Fisso / Fixed

Piano in vetro o ceramic o impiallacciato frassino.  
Glass, Ceramic or ash wood veneered top.

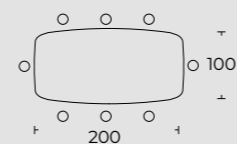
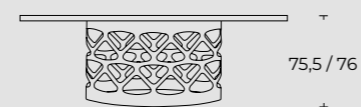

Piano sagomato in vetro sp. 12 mm, Ceramic sp. 13 mm.  
o impiallacciato in frassino spazzolato sp. 30 mm.  
Shaped top in glass thk 12 mm, ceramic thk 13 mm or  
brushed veneered ash wood thk 30 mm.

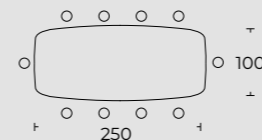

Piano sagomato in vetro sp. 12 mm, Ceramic sp. 13 mm.  
o impiallacciato in frassino spazzolato sp. 30 mm.  
Shaped top in glass thk 12 mm, ceramic thk 13 mm or  
brushed veneered ash wood thk 30 mm.

Per le finiture di gambe e piani vedere il campionario My Sample  
e indicazioni del Listino in vigore.

For the finishings of legs and tops see My Samples collection  
and indications of price list in effect at the time.





## COSMO

Design Giuseppe Farinola

Le quattro gambe del tavolo COSMO sono elementi che richiamano verso l'alto, quasi dei raggi traenti che sollevano ed elevano davvero verso un nuovo spazio. Il punto di contatto a terra, ampio e importante, diventa un volume che all'apparenza si assottiglia mano a mano che le gambe si avvicinano al cuore tecnologico del tavolo, quel meccanismo impercettibile che allunga il piano del tavolo ed espande il living ad orizzonti nuovi con raffinata leggerezza.

The four legs of the COSMO table are elements that almost recall upward rays that really lift and elevate to a new space. The contact point to the ground, broad and important, becomes a volume that apparently tapers off as the legs approach the technological heart of the table, that imperceptible mechanism that extends the top of the table and expands the living room to new horizons with refined lightness.



COSMO T72

Tavolo Cosmo T72, rettangolare allungabile, metallo bronzo spazzolato, piano Ceramic Noir Desir lucido.  
Sedia Alyssa S118, frassino tabacco RV.T24, lana antracite.  
Cosmo table T72, rectangular extendable, brushed bronze metal, glossy Noir Desir Ceramic top.  
Alyssa chair S118, tobacco ash wood RV.T24, anthracite wool.







### **COSMO T72**

**Tavolo Cosmo T72, rettangolare allungabile, metallo bronzo spazzolato, piano Ceramic Noir Desir lucido.**  
Cosmo table T72, rectangular extendable, brushed bronze metal, glossy Noir Desir Ceramic top.





## COSMO T72

Tavolo Cosmo T72, fisso, metallo bronzo spazzolato, piano scortecciato sp.45 mm in frassino noce canaletto RV.NC22. Sedia Lavinia S158FR, frassino noce canaletto RV.NC22, ecopelle Desert.  
Cosmo table T72, fixed, brushed bronze metal, debarked top thk 45mm top in Canaletto walnut ash wood RV.NC22. Lavinia chair S158FR, Canaletto walnut RV.NC22 ash wood, Desert leatherette.





## COSMO T72

**Tavolo Cosmo T72, sagomato allungabile, metallo oro rosa, piano vetro extrabianco lucido VXW.**  
**Poltrona Janis S165MC, metallo oro rosa, velluto brandy.**  
Cosmo table T72, shaped extendable, rose gold metal, glossy extrawhite VXW glass top.  
Janis armchair S165MC, rose gold metal, brandy velvet.



**COSMO T72**

**Tavolo Cosmo T72, sagomato allungabile, metallo oro rosa, piano vetro extrabianco lucido VXW.  
Poltrona Janis S165MC, metallo oro rosa, velluto brandy.**

Cosmo table T72, shaped extendable, rose gold metal, glossy extrawhite glass top VXW.  
Janis armchair S165MC, rose gold metal, brandy velvet.





### COSMO T72

Tavolo Cosmo T72, rettangolare allungabile, metallo antracite, piano Ceramic Sahara Noir bocciardato. Sedia Cleo S154FR e poltrona Demetra S155FR, frassino laccato nero, tessuto Victoria terracotta.  
 Cosmo table T72, rectangular extendable, anthracite metal, bush-hammered Sahara Noir Ceramic top. Cleo chair S154FR and Demetra armchair S155FR, black lacquered ash wood, terracotta Victoria fabric.







### **COSMO T72**

**Tavolo Cosmo T72, fisso, metallo bianco, piano sagomato 250x100 Ceramic Arabescato lucido.**

**Sedia Cleo S154MX, metallo bianco, lana grigio chiaro.**

Cosmo table T72, fixed, white metal, 250x100 glossy Arabesque Ceramic shaped top.

Cleo chair S154MX, white metal, light grey wool.





## COSMO T72

Tavolo Cosmo T72, allungabile syncro, metallo antracite, piano melaminico tavolato Royal Oak 988. Sedia Lavinia S158MC, metallo antracite, ecopelle antracite.  
Cosmo table T72, syncro extendable, anthracite metal, plank Royal oak 988 melamine top.  
Lavinia chair S158MT, anthracite metal, anthracite leatherette.



COSMO T72

Tavolo Cosmo T72, fisso, metallo oro spazzolato, piano sagomato 250x100 Ceramic Emperador lucido.  
Sedia Cleo S154FR, frassino Bruciato RV.B.71, velluto Louvre Mouse.  
Cosmo table T72, fixed, brushed golden metal, 250x100 glossy Emperador Ceramic shaped top.  
Cleo chair S154FR, burnt ash wood RV.B.71, Mouse Louvre velvet.





## COSMO T72

Tavolo Cosmo T72, fisso, metallo oro spazzolato, piano sagomato 250x100 Ceramic Emperador lucido.  
Sedia Cleo S154FR, frassino Bruciato RV.B.71, velluto Louvre Mouse.  
Cosmo table T72, fixed, brushed golden metal, 250x100 glossy Emperador Ceramic shaped top.  
Cleo chair S154FR, burnt ash wood RV.B.71, Mouse Louvre velvet.



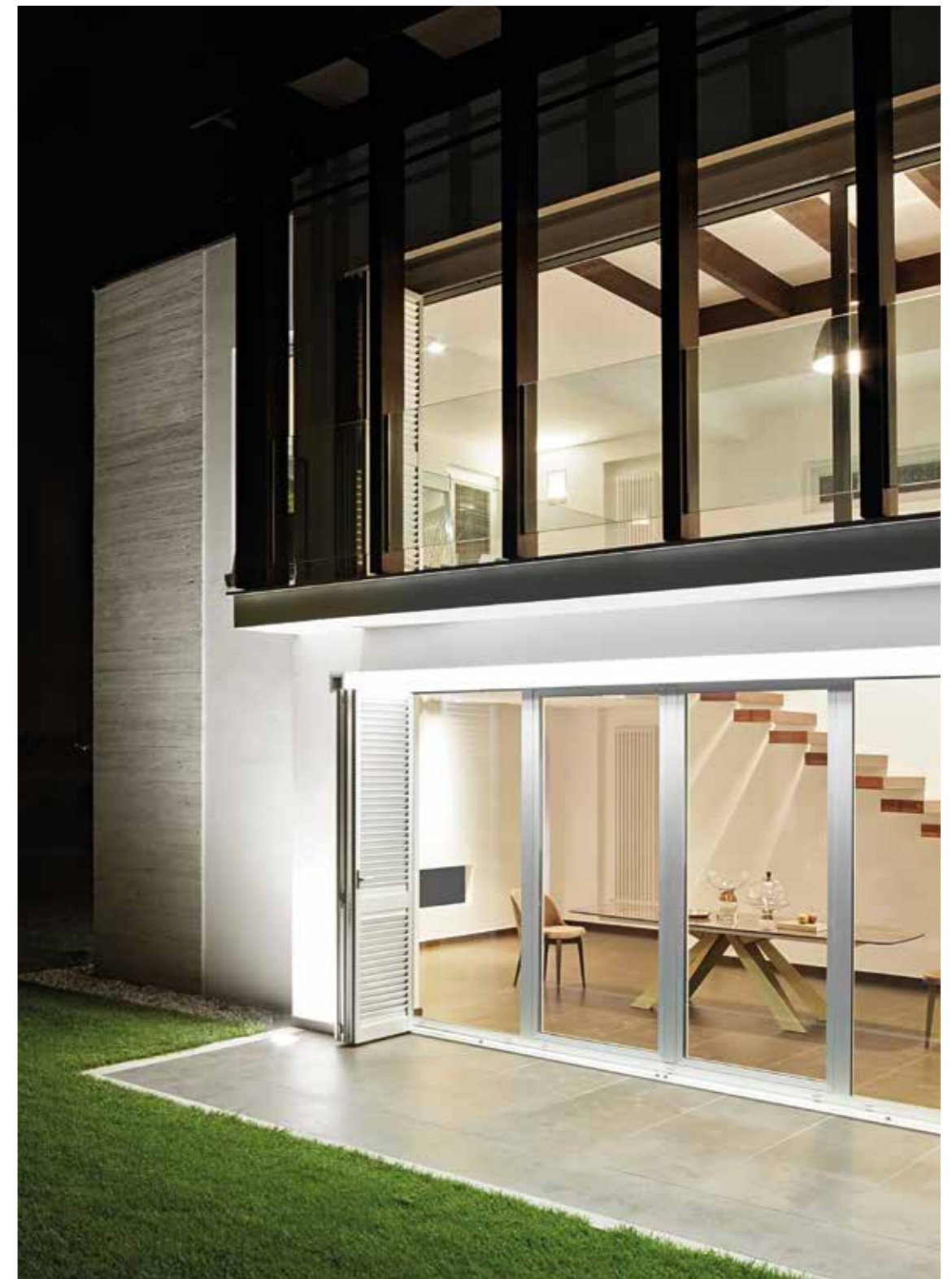

**COSMO T72**

Tavolo Cosmo T72, fisso, metallo oro spazzolato,  
piano sagomato 250x100 Ceramic Emperador lucido.  
Cosmo table T72, fixed, brushed golden metal,  
250x100 glossy Emperador Ceramic shaped top.





## COSMO T72

Tavolo Cosmo T72, rettangolare allungabile, metallo nichel spazzolato, piano vetro extrabianco VXW. Sedia City S127 lana antracite.  
Cosmo table T72, rectangular extendable, brushed nickel metal, extrawhite VXW glass top.  
City chair S127, anthracite wool.



## COSMO T72

Tavolo Cosmo T72, sagomato allungabile, piano Ceramic Arabescato lucido.

Sedia Vanilla S167, metallo antracite, tessuto Victoria june bug.

Cosmo table T72, shaped extendable, glossy Arabesque Ceramic top.

Vanilla chair S167, anthracite metal, june bug Victoria fabric.





**COSMO T72**

**Tavolo Cosmo T72, fisso, metallo antracite, piano sagomato 250x100 Ceramic Pietra grey opaco.**  
**Sedia Demetra S155MX, metallo antracite, lana antracite.**  
Cosmo table T72, fixed, anthracite metal, 250x100 matt Grey Stone Ceramic shaped top.  
Demetra chair S155MX, anthracite metal, anthracite wool.





## COSMO T72

Allungabile full automatic / Full automatic extendable



Allungabile automatico con allunghe laterali simmetriche.

Piani in vetro spess. 12 mm. o Ceramic spess. 13 mm.

Automatically extendable with symmetrical side extensions.

Glass top thk 12 mm or Ceramic top thk 13 mm.

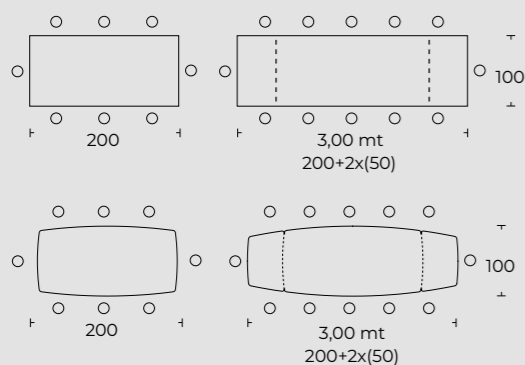

## COSMO T72

Superallungabile Syncro / Super extendable syncro

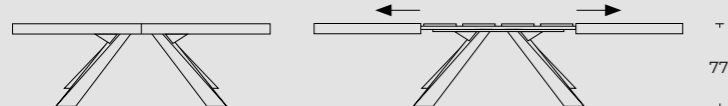

Meccanismo multiprolunghe ad apertura telescopica sincronizzata. Le allunghe sono alloggiare in un apposito scomparto interno. Piano folding in melaminico h 80 mm.

Multiextension mechanism synchronized telescopic opening. The extensions are fitted inside the table. Melamine folding tops h 80 mm.

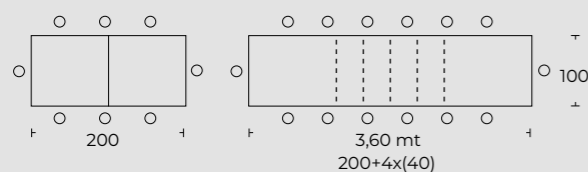

Meccanismo multiprolunghe ad apertura telescopica sincronizzata. Le allunghe sono alloggiare in un apposito scomparto interno. Piano folding impiallacciato in frassino spazzolato h 80 mm.

Multiextension mechanism synchronized telescopic opening. The extensions are fitted inside the table. Brushed veneered ash wood folding top h 80 mm.

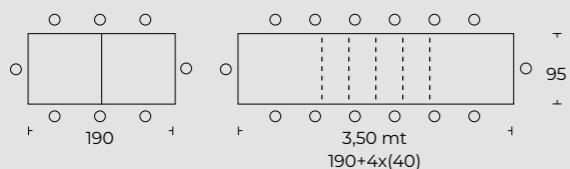

## COSMO T72

Fisso / Fixed

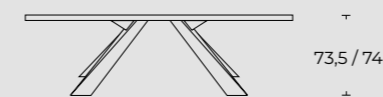

Piano in vetro, ceramic o impiallacciato frassino. / Glass, ceramic or ash wood veneered top.

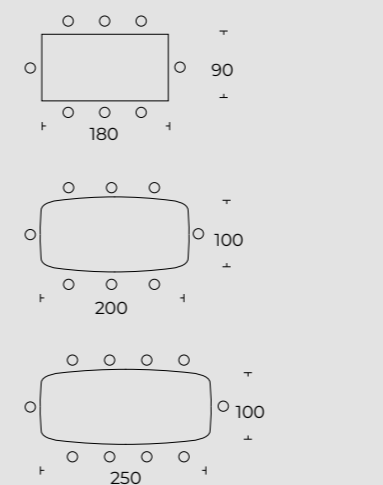

Piano rettangolare in vetro sp.8 mm. o Ceramic sp. 11 mm.  
Rectangular top in glass thk 8 mm or ceramic thk 11 mm.

Piano sagomato in vetro sp. 12 mm, Ceramic sp. 13 mm.  
o impiallacciato in frassino spazzolato sp. 30 mm.  
Shaped top in glass thk 12 mm, ceramic thk 13 mm or  
brushed veneered ash wood thk 30 mm.

Piano sagomato in vetro sp. 12 mm, Ceramic sp. 13 mm.  
o impiallacciato in frassino spazzolato sp. 30 mm.  
Shaped top in glass thk 12 mm, ceramic thk 13 mm or  
brushed veneered ash wood thk 30 mm.

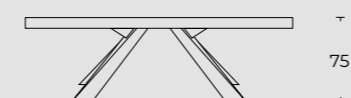

Piano in frassino scortecciato. / Ash wood top with debarked effect

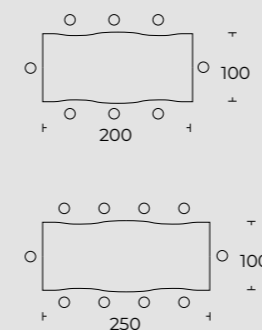

Piano in frassino con effetto scortecciato sp. 45 mm.  
Ash wood top with debarked effect thk 45 mm.

Piano in frassino con effetto scortecciato sp. 45 mm.  
Ash wood top with debarked effect thk 45 mm.

Per le finiture di gambe e piani vedere il campionario My Sample e indicazioni del Listino in vigore.

For the finishings of legs and tops see My Samples collection and indications of price list in effect at the time.





## ATLANTE

Design R & D Friulsedie

Le gambe del tavolo si trasformano in un unico lungo filo. La base del tavolo ATLANTE può essere tutto quello che volete immaginare: l'intreccio di meridiani e paralleli che ordina il pianeta, oppure un gioco di fili spensierato e leggero, come se delle mani invisibili potessero cambiarne la geometria ad ogni spostamento di prospettiva. Eppure ATLANTE è proprio come il mito che sostiene il solido equilibrio di un mondo: può essere quello del vostro living o della convivialità, anche alla lunghezza massima del piano, mantiene sempre proporzioni eleganti e una solidità impeccabile.

The legs of the table transform into a single long line. The base of the ATLANTE table can be everything you want to imagine: the intertwining of meridians and parallels that orders the planet, or a light and carefree play of threads, as if invisible hands could change its geometry at each perspective shift. Yet ATLANTE is just like the myth that bears the solid balance of a world: it can be that of your living room or conviviality, even at the maximum length of the top; it always maintains elegant proportions and impeccable solidity.



## ATLANTE T70

Tavolo Atlante T70, fisso, metallo oro rosa, piano sagomato 250x100  
impiallacciato rovere bruciato RV.B.71.

Sedia Mia S151MT, metallo oro rosa, tessuto Victoria elephant.

Atlante table T70, fixed, rose gold metal,  
250x100 burnt ash wood RV.B.71 shaped veneered top.  
Mia chair S151MT, rose gold metal, elephant Victoria fabric.





**ATLANTE T70**

Tavolo Atlante T70, fisso, metallo oro rosa, piano sagomato 250x100 impiallacciato rovere bruciato RV.B.71.

Sedia Mia S151MT, metallo oro rosa, tessuto Victoria elephant.

Atlante table T70, fixed, rose gold metal, 250x100 burnt ash wood RV.B.71 shaped veneered top.

Mia chair S151MT, rose gold metal, elephant Victoria fabric.





### ATLANTE T70

Tavolo Atlante T70, fisso, metallo oro antico, piano sagomato 250x100 vetro velvet opaco nero A.V.N.  
Poltrona Demetra S155MX, metallo oro antico, velluto green.

Atlante table T70, fixed, antique gold metal, 250x100 matt black A.V.N. shaped glass top.  
Demetra armchair S155MX, antique gold metal, green velvet.





### ATLANTE T70

Tavolo Atlante T70, rettangolare allungabile, metallo bianco, piano Ceramic Arabescato lucido.  
 Sedia Cleo S154MX, metallo bianco, lana tabacco.  
 Atlante table T70, rectangular extendable, white metal, glossy Arabesque ceramic top.  
 Cleo chair S154MX, white metal, tobacco wool.







### ATLANTE T70

Tavolo Atlante T70, fisso, metallo cromato, piano scortecciato sp.45 mm in frassino Bruciato RV.B.71.

Sedia City S127, lana azzurra.

Atlante table T70, fixed, chrome metal, debarked top thk 45mm in Burnt ash RV.B.71.

City chair S127, light blue wool.



## ATLANTE T70

Tavolo Atlante T70, fisso, piano sagomato 250x100 Ceramic Noir Desir lucido.  
Sedia Lavinia S158MX, metallo antracite, ecopelle Desert.  
Atlante table T70, fixed, 250x100 glossy Ceramic Noir Desir shaped top.  
Lavinia chair S158MX, anthracite metal, Desert leatherette.







### ATLANTE T70

Tavolo Atlante T70, fisso, metallo antracite, piano sagomato 250x100 Ceramic Noir Desir lucido.  
Sedia Cleo S154MX, metallo antracite, lana antracite.  
Atlante table T70, fixed, anthracite metal, 250x100 glossy Ceramic Noir Desir shaped top.  
Cleo chair S154MX, anthracite metal, anthracite wool.



## ATLANTE T70

Tavolo Atlante T70, fisso, metallo cromato, piano sagomato 250x100 Ceramic Noir Desir lucido.  
Sedia Olympia S117MC, metallo antracite, tessuto Queens brown.  
Atlante table T70, fixed, chrome metal, 250x100 glossy Noir Desir Ceramic shaped top.  
Olympia chair S117MC, anthracite metal, brown Queens fabric.





## ATLANTE T70

Allungabile full automatic / Full automatic extendable

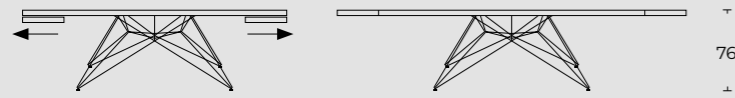

Allungabile automatico con allunghe laterali simmetriche.  
Piani in vetro spess. 12 mm. o Ceramic spess. 13 mm.

Automatically extendable with symmetrical side extensions.  
Glass top thk 12 mm or Ceramic top thk 13 mm.

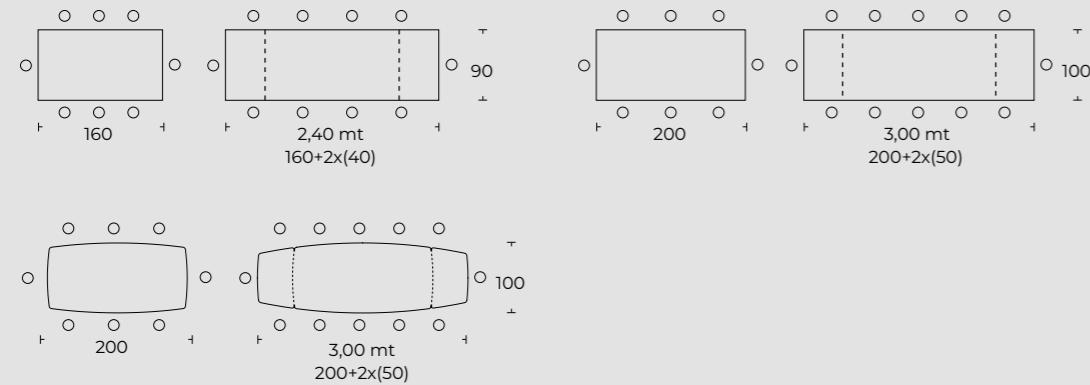

## ATLANTE T70

Superallungabile Syncro / Super extendable syncro

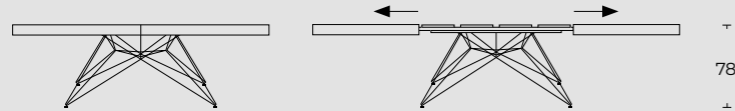

Meccanismo multiprolunghe ad apertura telescopica sincronizzata. Le allunghe sono alloggiare in un apposito scomparto interno. Piano folding impiallacciato in frassino spazzolato o noce americano o in melaminico h 80 mm.

Multiextension mechanism synchronized telescopic opening. The extensions are fitted inside the table. Brushed veneered ash wood or American walnut or melamine folding tops h 80 mm.

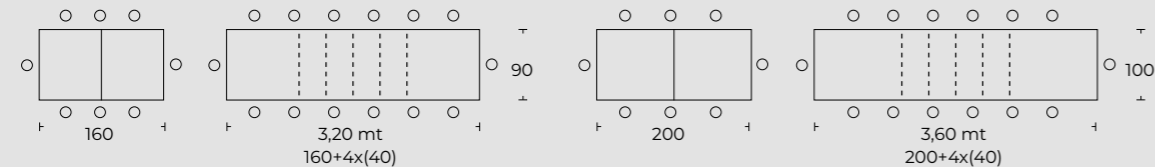

Meccanismo multiprolunghe ad apertura telescopica sincronizzata. Le allunghe sono alloggiare in un apposito scomparto interno. Piano folding impiallacciato in frassino spazzolato h 80 mm.

Multiextension mechanism synchronized telescopic opening. The extensions are fitted inside the table. Brushed veneered ash wood folding top h 80 mm.

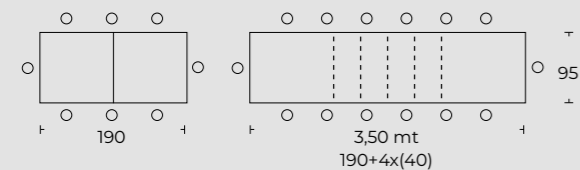

## ATLANTE T70

Fisso / Fixed

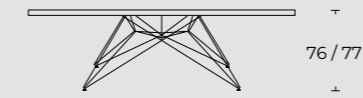

Piano in vetro, ceramic o impiallacciato frassino / Glass, ceramic or ash wood veneered top

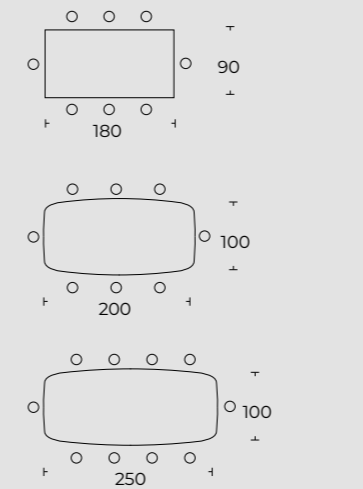

Piano rettangolare in vetro sp.8 mm. o Ceramic sp. 11 mm.  
Rectangular top in glass thk 8 mm or ceramic thk 11 mm.

Piano sagomato in vetro sp. 12 mm, Ceramic sp. 13 mm.  
o impiallacciato in frassino spazzolato sp. 30 mm.

Shaped top in glass thk 12 mm, ceramic thk 13 mm or brushed veneered ash wood thk 30 mm.

Piano sagomato in vetro sp. 12 mm, Ceramic sp. 13 mm.  
o impiallacciato in frassino spazzolato sp. 30 mm.

Shaped top in glass thk 12 mm, ceramic thk 13 mm or brushed veneered ash wood thk 30 mm.

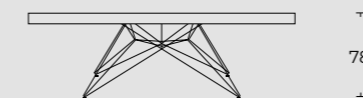

Piano in frassino scortecciato / Ash wood top with debarked effect

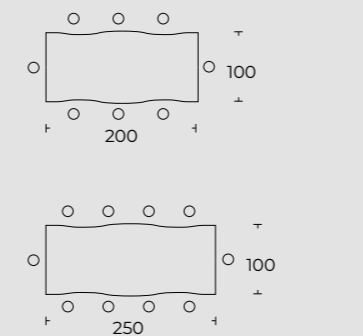

Piano in frassino con effetto scortecciato sp. 45 mm.  
Ash wood top with debarked effect thk 45 mm.

Piano in frassino con effetto scortecciato sp. 45 mm.  
Ash wood top with debarked effect thk 45 mm.

Per le finiture di gambe e piani vedere il campionario My Sample e indicazioni del Listino in vigore.

For the finishings of legs and tops see My Samples collection and indications of price list in effect at the time.





## BOSTON

Design R & D Friulsedie

Fra i tavoli allungabili e a piano fisso BOSTON è l'icona che resta oltre il tempo e gli spazi. È un tavolo di alto profilo che apre a tantissime configurazioni, le cui finiture possono declinarsi in ogni ambiente. Quella di BOSTON è una concezione di spazio che poggia leggera sull'esclusivo incrocio della gamba, irregolare e perfettamente in equilibrio come la natura. Sempre leggero sia nella declinazione in tavolo allungabile che in quella a piano fisso, grazie ai materiali e alla sostanza del progetto, elementi che rendono BOSTON unico e molteplice.

Among the extendable and fixed tables, BOSTON is the icon that remains beyond time and space. It is a high-profile table that opens up to many configurations, whose finishes can be appreciated in any environment. That of BOSTON is a conception of space that rests lightly on the exclusive cross of the leg, irregular and perfectly balanced like nature. Always light both in the extendable table version and in the fixed table version thanks to the materials and substance of the project, elements that make BOSTON unique and multiple.



## BOSTON T50

Tavolo Boston T50, allungabile syncro, metallo oro rosa, piano melaminico ossido.  
Poltrona Janis S165MC, metallo oro rosa, tessuto Victoria caramel.  
Boston table T50, syncro extendable, rose gold metal, oxide melamine top.  
Janis armchair S165MC, rose gold metal, caramel Victoria fabric.







## BOSTON T50

Tavolo Boston T50, allungabile syncro, metallo multicolor smart, piano tavolato Royal Oak.  
Sedia Gran Manon S141FR, frassino laccato titanio wood, rigenerato di cuoio bianco.  
Boston table T50. syncro extendable. smart multicolor metal. plank Royal oak.  
Gran Manon chair S141FR. lacquered wood titanium, white regenerated leather.



## BOSTON T50

Tavolo Boston T50, fisso, metallo bicolore,  
piano sagomato 250x100 Ceramic Fokos nero opaco.  
Sedia Noah S116MC, metallo ottone, tessuto Queens graphite.  
Boston table T50, fixed, bicolor metal, 250x100 matt black Fokos ceramic top.  
Noah chair S116MC, brass metal, graphite Queens fabric.







**BOSTON T50**

Tavolo Boston T50, fisso, metallo bicolore, piano sagomato 250x100 Ceramic Fokos nero opaco.  
Boston table T50, fixed, bicolor metal, 250x100 matt black Fokos ceramic top.



## BOSTON T50

Tavolo Boston T50, rettangolare allungabile,  
metallo nichel spazzolato, piano Ceramic Arabescato lucido.  
Sedia Margie S104V, metallo antracite, ecopelle antracite.  
Boston table T50, rectangular extendable, brushed nickel metal,  
glossy Arabesque Ceramic top.  
Margie chair S104V, anthracite metal, anthracite leatherette.







### **BOSTON T50**

Tavolo Boston T50, rettangolare allungabile, metallo nichel spazzolato, piano Ceramic Arabescato lucido.  
Boston table T50, rectangular extendable, brushed nickel metal, glossy Arabesque Ceramic top.





## BOSTON T50

Tavolo Boston T50, fisso, metallo bronzo spazzolato, piano scortecciato sp.45 mm in frassino Bruciato RV.B.71.  
Sedia Mia S151FR, frassino Bruciato RV.B.71, ecopelle fango.  
Boston table T50, fixed, brushed bronze metal, debarked top thk 45mm top in burnt ash RV.B.71.  
Mia chair S151FR, burnt ash RV.B.71, mud leatherette.



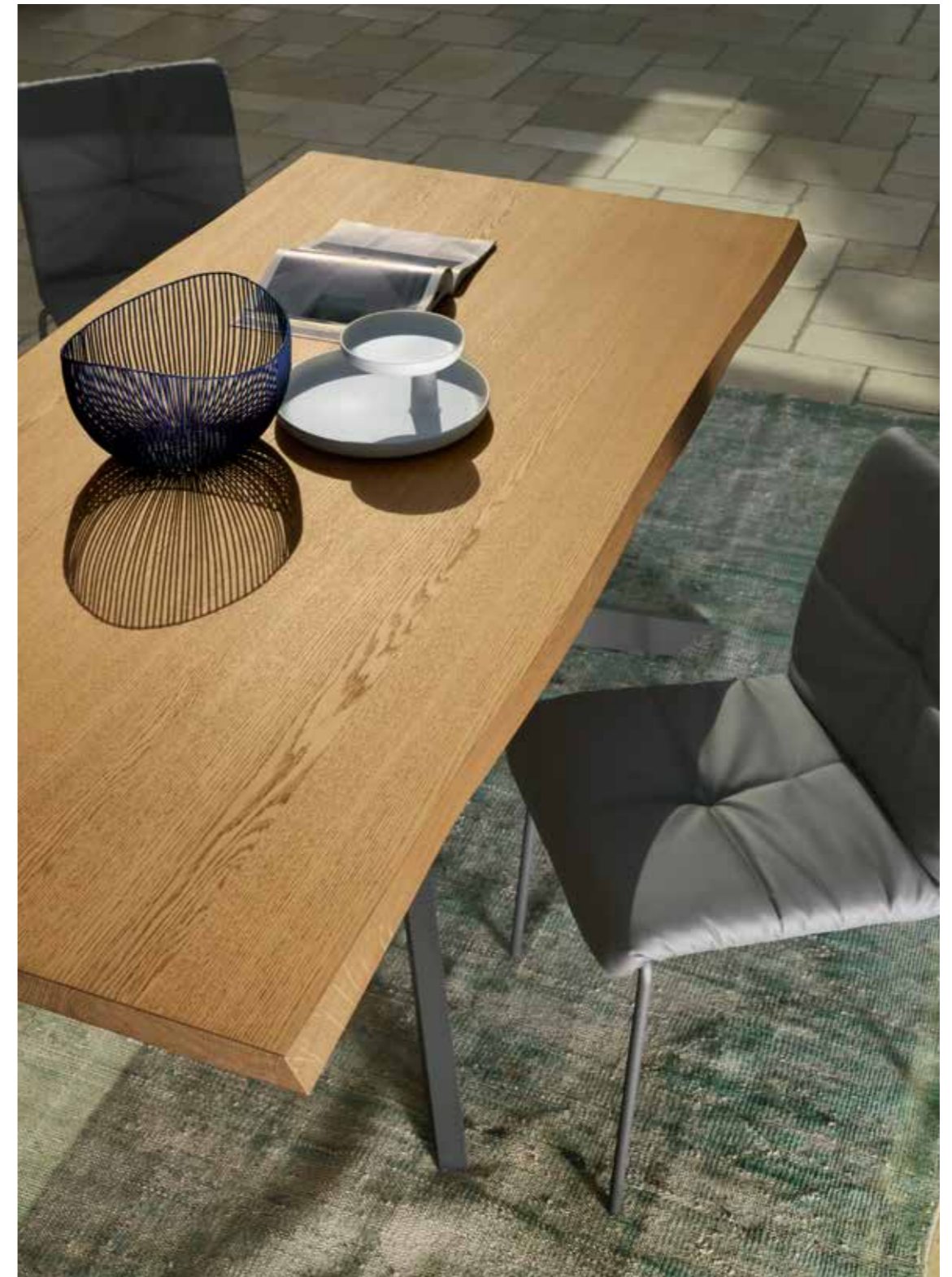

**BOSTON T50**

Tavolo Boston T50, fisso, metallo antracite, piano scortecciato sp. 45 mm in frassino Royal Oak RV.RO.38. Sedia Fanny S152MT, metallo antracite, ecopelle antracite.  
Boston table T50, fixed, anthracite metal, debarked top thk 45mm in ash Royal oak RV.RO.38.  
Fanny chair S152MT, anthracite metal, anthracite leatherette.





## BOSTON T50

Tavolo Boston T50, fisso, metallo oro spazzolato, piano sagomato 250x100  
Keramic Noir Desir lucido. Poltrona Olympia S117MC, metallo antracite, ecopelle antracite.  
Boston table T50, fixed, brushed golden metal, 250x100 glossy Noir Desir Ceramic shaped top.  
Olympia chair S117MC, anthracite metal, anthracite leatherette.



## BOSTON T50

Tavolo Boston T50, fisso, piano sagomato 250x100 Ceramic Calacatta lucido.  
Sedia Cleo S154MX, metallo antracite, lana tabacco.  
Boston table T50, fixed, 250x100 glossy Calacatta Ceramic shaped top.  
Cleo chair S154MX, anthracite metal, tobacco wool.





## BOSTON T50

Tavolo Boston T50, fisso, metallo oro spazzolato, piano sagomato 250x100 Ceramic Calacatta lucido.  
Sedia Cleo S154FR, frassino tabacco RV.T.24, velluto Louvre mouse.  
Boston table T50, fixed, brushed golden metal, 250x100 glossy Calacatta Ceramic shaped top.  
Cleo chair S154FR, tobacco ash RV.T.24, mouse Louvre velvet.





## BOSTON T50

Allungabile full automatic / Full automatic extendable



Allungabile automatico con allunghe laterali simmetriche.

Piani in vetro spess. 12 mm. o Ceramic spess. 13 mm.

Automatically extendable with symmetrical side extensions.

Glass top thk 12 mm or Ceramic top thk 13 mm.

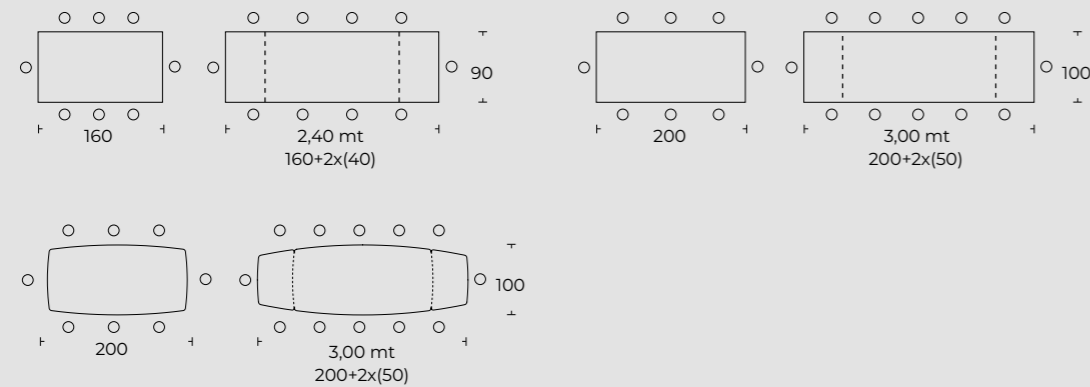

## BOSTON T50

Superallungabile Syncro / Super extendable syncro

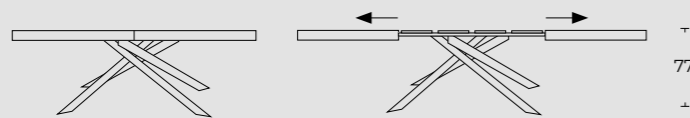

Meccanismo multiprolunghe ad apertura telescopica sincronizzata. Le allunghe sono alloggiare in un apposito scomparto interno. Piano folding impiallacciato in frassino spazzolato o noce americano o in melaminico h 80 mm.

Multiextension mechanism synchronized telescopic opening. The extensions are fitted inside the table. Brushed veneered ash or American walnut or melamine folding tops h 80 mm.

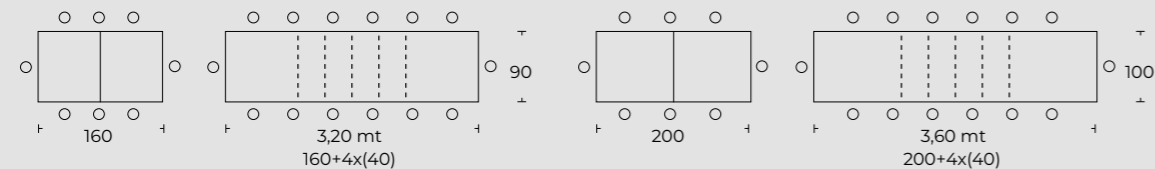

Meccanismo multiprolunghe ad apertura telescopica sincronizzata. Le allunghe sono alloggiare in un apposito scomparto interno. Piano folding impiallacciato in frassino spazzolato h 80 mm.

Multiextension mechanism synchronized telescopic opening. The extensions are fitted inside the table. Brushed veneered ash wood folding top h 80 mm.

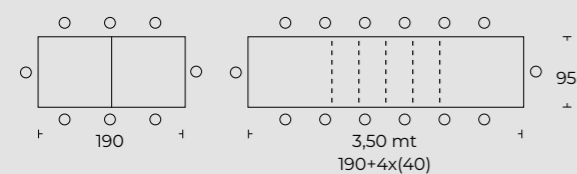

## BOSTON T50

Fisso / Fixed

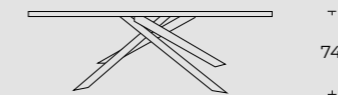

Piano in vetro, ceramic o impiallacciato frassino. / Glass, ceramic or ash wood veneered top.

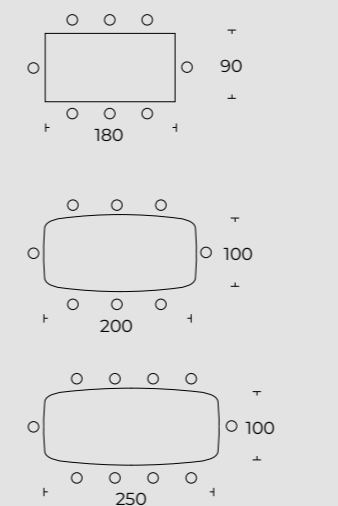

Piano rettangolare in vetro sp.8 mm. o Ceramic sp. 11 mm.  
Rectangular top in glass thk 8 mm or ceramic thk 11 mm.

Piano sagomato in vetro sp. 12 mm, Ceramic sp. 13 mm.  
o impiallacciato in frassino spazzolato sp. 30 mm.  
Shaped top in glass thk 12 mm, ceramic thk 13 mm or  
brushed veneered ash wood thk 30 mm.

Piano sagomato in vetro sp. 12 mm, Ceramic sp. 13 mm.  
o impiallacciato in frassino spazzolato sp. 30 mm.  
Shaped top in glass thk 12 mm, ceramic thk 13 mm or  
brushed veneered ash wood thk 30 mm.

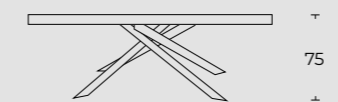

Piano in frassino scortecciato. / Ash wood top with debarked effect.

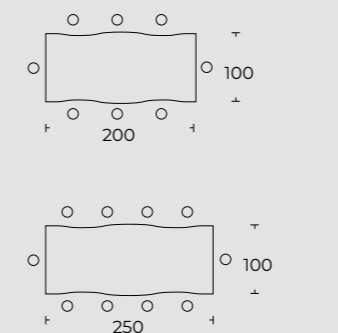

Piano in frassino con effetto scortecciato sp. 45 mm.  
Ash wood top with debarked effect thk 45 mm.

Piano in frassino con effetto scortecciato sp. 45 mm.  
Ash wood top with debarked effect thk 45 mm.

Per le finiture di gambe e piani vedere il campionario My Sample e indicazioni del Listino in vigore.

For the finishings of legs and tops see My Samples collection and indications of price list in effect at the time.





## PORTLAND

Design Giuseppe Farinola

Le due gambe del tavolo PORTLAND sembrano arrivare da un'altra dimensione. Due elementi di sostegno importanti con un taglio asimmetrico, che sembrano evocare energie secolari di trasformazioni e continuo movimento. Pur nella loro immediata solidità, sono due monoliti che lasciano sia lo sguardo a suggerirne la rotazione, ma anziché fluttuare nello spazio sono una solida base d'appoggio per mille superfici. PORTLAND è un omaggio alla forza del dinamismo, un tavolo che più allunga il piano e meglio può esprimere quell'idea di universo in espansione.

The two legs of the PORTLAND table seem to come from another dimension. Two elements of important support with an asymmetrical cut, which seem to evoke centuries-old energies of transformations and continuous movement. Despite their immediate solidity, they are two monoliths that let the gaze suggest its rotation, but instead of floating in space, they are a solid support base for a thousand surfaces. PORTLAND is a tribute to the strength of dynamism, a table that the more the top stretches the better it can express that idea of an expanding universe.



PORTLAND T55

Tavolo Portland T55, fisso, metallo ottone,  
piano sagomato 250x100 Ceramic Invisible White opaco.  
Poltrona Demetra S155MC, metallo ottone, tessuto Victoria lizard green.  
Portland table T55, fixed, brass metal, 250x100 matt Invisible White Ceramic shaped top.  
Demetra armchair S155MC, brass metal, lizard green Victoria fabric.





**PORTLAND T55**

Tavolo Portland T55, sagomato allungabile, piano Ceramic Invisible White opaco.

Sedia Vanilla S167, metallo ottone, tessuto Victoria lizard green.

Portland table T55, shaped extendable, brass metal, matt Invisible White Ceramic shaped top.  
Vanilla chair S167, brass metal, lizard green Victoria fabric.







### PORTLAND T55

Tavolo Portland T55, fisso, metallo ottone, piano sagomato 250x100 Ceramic Arabescato lucido.  
Poltrona Janis S165MC, metallo ottone, tessuto Victoria caramel.  
Portland table T55, fixed, brass metal, 250x100 glossy Arabesque Ceramic shaped top.  
Janis armchair S165MC, brass metal, caramel Victoria fabric.





## PORTLAND T55

Tavolo Portland T55, allungabile, metallo bianco, piano vetro extrabianco VXW lucido.

Sedia Cleo S154MX, metallo bianco, velluto Louvre Steel.

Portland table T55, extendable, white metal, glossy extrawhite glass top VXW.

Cleo chair S154MX, white metal, Steel Louvre velvet.







## PORTLAND T55

Tavolo Portland T55, fisso, metallo antracite, piano Ceramic marmo Statuario opaco.

Sedia Cleo S154FR, frassino Bruciato RV.B.71, ecopelle bianco.

Portland table T55, fixed, anthracite metal, matt marble Statuary Ceramic top.

Cleo chair S154FR, burnt ash wood RV.B.71, white leatherette.



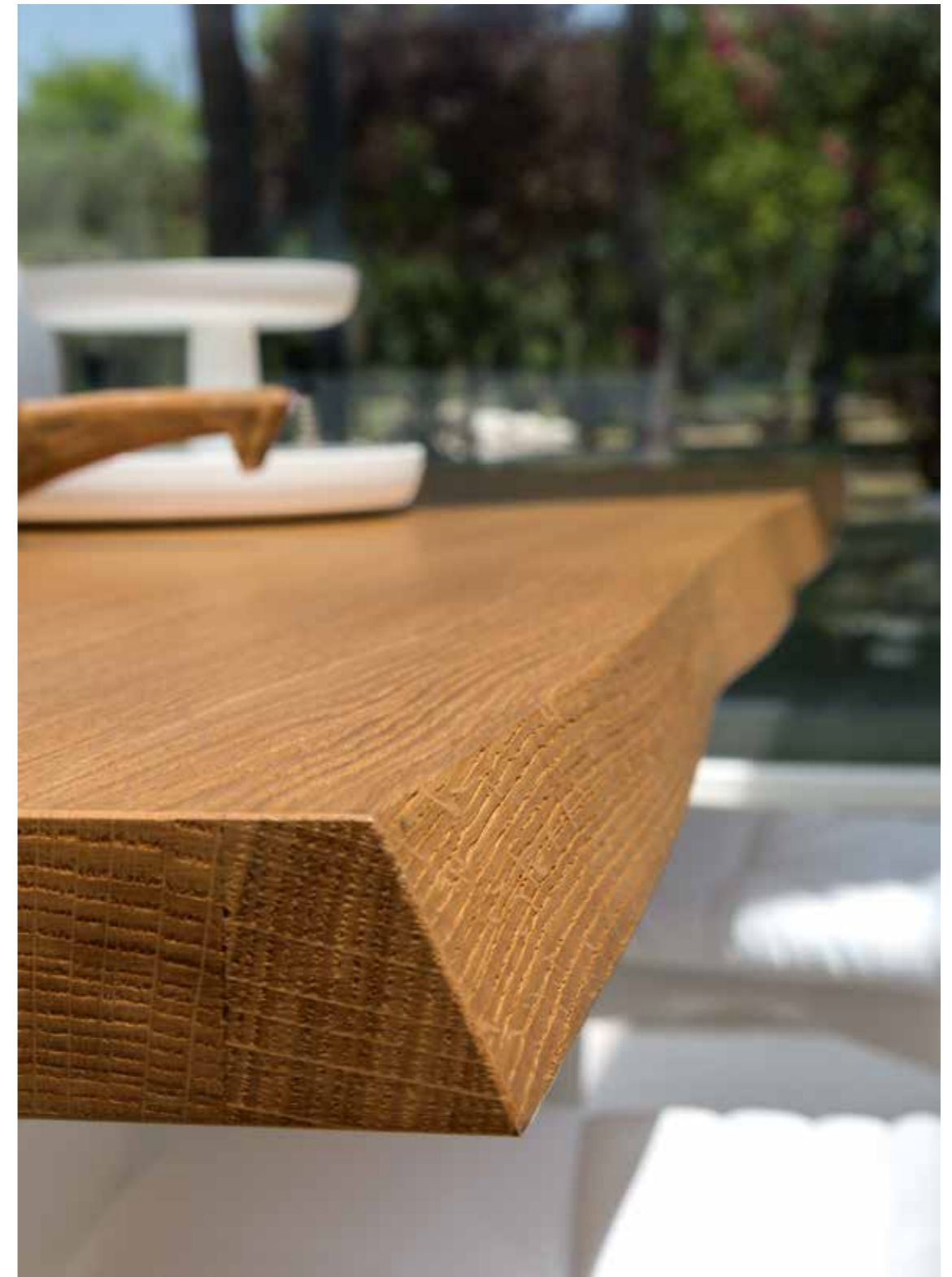

**PORTLAND T55**

Tavolo Portland T55 fisso, metallo bianco, piano scortecciato sp. 45 mm in frassino Royal Oak RV.RO.38.  
 Sedia Fanny S152FR, frassino laccato bianco, ecopelle bianco.  
 Portland table T55, fixed, white metal, debarked top thk 45mm in ash wood Royal oak RV.RO.38.  
 Fanny chair S152FR, white lacquered ash wood, white leatherette.





### PORTLAND T55

Tavolo Portland T55, allungabile Syncro, metallo antracite, piano melaminico tavolato Royal Oak 988. Sedia Fanny S152MT, metallo antracite, ecopelle antracite.  
Portland table T55, syncro extendable, anthracite metal, plank Royal Oak 988 melamine top.  
Fanny chair S152MT, anthracite metal, anthracite leatherette.



## PORTLAND T55

Tavolo Portland T55, fisso, piano sagomato 250x100 Ceramic Pietra Grey opaco.

Sedia Demetra S155MX, metallo antracite, lana antracite.

Portland table T55, fixed. 250x100 matt Grey Stone ceramic shaped top.

Demetra chair S155MX. anthracite metal, anthracite wool.





**PORTLAND T55**

**Tavolo Portland T55, fisso, metallo antracite, piano sagomato 250x100 Ceramic Pietra Grey.  
Sedia Kylian S153MC, metallo antracite, ecopelle antracite.**  
Portland table T55, fixed, anthracite metal, 250x100 matt Grey Stone Ceramic shaped top.  
Kylian chair S153MC, anthracite metal, anthracite leatherette.





## PORTLAND T55

Allungabile full automatic / Full automatic extendable



Allungabile automatico con allunghe laterali simmetriche.

Piani in vetro spess. 12 mm. o Ceramic spess. 13 mm.

Automatically extendable with symmetrical side extensions.

Glass top thk 12 mm or Ceramic top thk 13 mm.

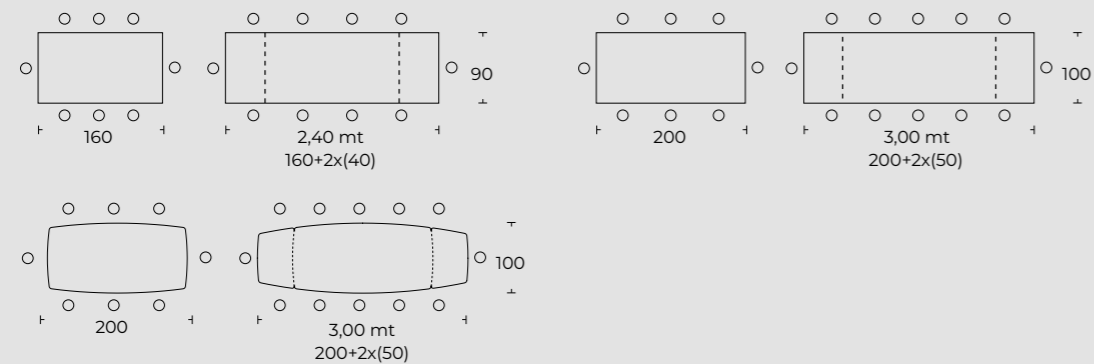

## PORTLAND T55

Superallungabile Syncro / Super extendable syncro



Meccanismo multiprolunghe ad apertura telescopica sincronizzata. Le allunghe sono alloggiare in un apposito scomparto interno. Piano folding impiallacciato in frassino spazzolato o noce americano o in melaminico h 80 mm.

Multiextension mechanism synchronized telescopic opening. The extensions are fitted inside the table. Brushed veneered ash wood or American walnut or melamine folding tops h 80 mm.

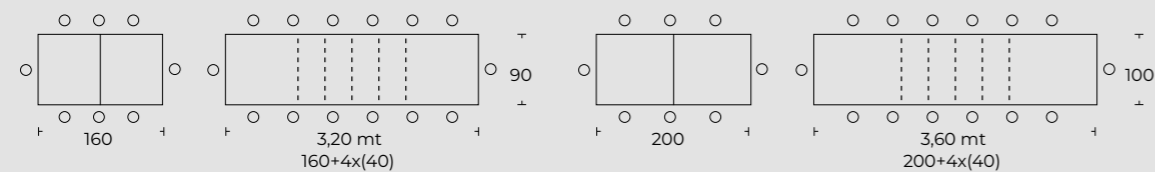

Meccanismo multiprolunghe ad apertura telescopica sincronizzata. Le allunghe sono alloggiare in un apposito scomparto interno. Piano folding impiallacciato in frassino spazzolato h 80 mm.

Multiextension mechanism synchronized telescopic opening. The extensions are fitted inside the table. Brushed veneered ash wood folding top h 80 mm.

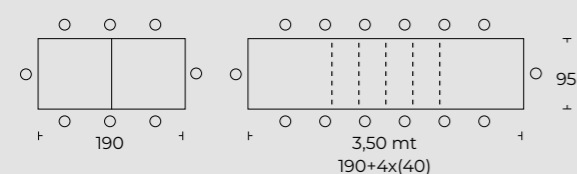

## PORTLAND T55

Fisso / Fixed



Piano in vetro, ceramic o impiallacciato frassino. / Glass, ceramic or ash wood veneered top.

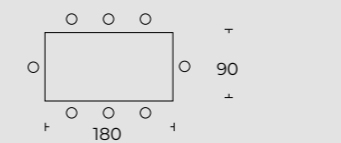

Piano rettangolare in vetro sp.8 mm. o Ceramic sp. 11 mm.  
Rectangular top in glass thk 8 mm or ceramic thk 11 mm.

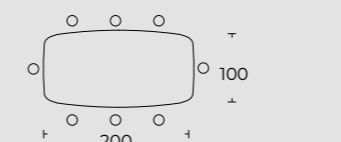

Piano sagomato in vetro sp. 12 mm, Ceramic sp. 13 mm.  
o impiallacciato in frassino spazzolato sp. 30 mm.  
Shaped top in glass thk 12 mm, ceramic thk 13 mm or  
brushed veneered ash wood thk 30 mm.

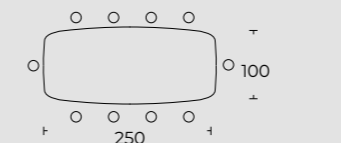

Piano sagomato in vetro sp. 12 mm, Ceramic sp. 13 mm.  
o impiallacciato in frassino spazzolato sp. 30 mm.  
Shaped top in glass thk 12 mm, ceramic thk 13 mm or  
brushed veneered ash wood thk 30 mm.



Piano in frassino scortecciato. / Ash wood top with debarked effect.

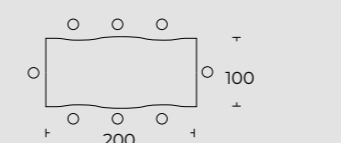

Piano in frassino con effetto scortecciato sp. 45 mm.  
Ash wood top with debarked effect thk 45 mm.

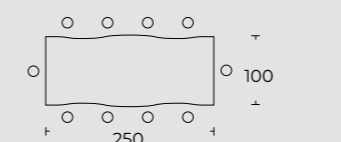

Piano in frassino con effetto scortecciato sp. 45 mm.  
Ash wood top with debarked effect thk 45 mm.

Per le finiture di gambe e piani vedere il campionario My Sample e indicazioni del Listino in vigore.

For the finishings of legs and tops see My Samples collection and indications of price list in effect at the time.





## OSAKA

Design Giuseppe Farinola

La leggerezza che rapisce e affascina lo sguardo è un respiro in trasparenza. Guardando OSAKA si indulge piacevolmente nell'illusione di due gambe piene, tanta è la sensazione della forza che sostiene il piano di questo tavolo, che può essere fisso o allungabile. Un progetto che attraversa il tempo e i confini, armonizzandosi con l'ispirazione orientale. Fosse carta potrebbe essere un origami, ma in OSAKA la base è appena un filo metallico, che diventa presto una trama di stile.

The lightness that captivates and fascinates the eye is a transparent breath. Looking at OSAKA, you pleasantly indulge in the illusion of two full legs, such is the sensation of the strength that supports the top of this table, which can be fixed or extendable. A project that crosses time and borders, harmonizing with oriental inspirations. If it were paper it could be an origami, but in OSAKA the base is just a metal line which soon becomes a texture of style.



## OSAKA T73

Tavolo Osaka T73, fisso, metallo cromato,  
piano sagomato 250x100 Ceramic Arabescato lucido.  
Sedia Kylian S153MX, metallo cromato, ecopelle bianco.  
Osaka table T73, fixed, chrome metal,  
250x100 glossy Ceramic Arabesque shaped top.  
Kylian chair S153MX, chrome legs, white leatherette.





**OSAKA T73**

Tavolo Osaka T73, fisso, metallo cromato, piano sagomato 250x100 Ceramic Arabescato lucido.

Sedia Kylian S153MX, gambe cromate, ecopelle bianca.

Osaka table T73, fixed, chrome metal, 250x100 glossy Ceramic Arabesque shaped top.

Kylian chair S153MX, chrome legs, white leatherette.





### OSAKA T73

Tavolo Osaka T73, rettangolare allungabile, metallo antracite, piano Ceramic Emperador lucido.  
Sedia City S127, lana antracite.

Osaka table T73, rectangular extendable, anthracite metal, glossy Emperador Ceramic top.  
City chair S127, anthracite wool.



## OSAKA T73

Tavolo Osaka T73, rettangolare allungabile, piano Ceramic Emperor lucido.  
Sedia Kylian S153MC, metallo antracite, ecopelle fango.

Osaka table T73, rectangular extendable, glossy Emperor Ceramic top.  
Kylian chair S153MC, anthracite metal, mud leatherette.







### OSAKA T73

Tavolo Osaka T73, fisso, metallo antracite, piano sagomato 250x100 impiallacciato noce canaletto RV.NC22. Poltrona Demetra S155MX, metallo antracite, lana antracite.  
Osaka table T73, fixed, anthracite metal, 250x100 shaped veneered top in Canaletto walnut RV.NC.22.  
Demetra armchair S155MX, anthracite metal, anthracite wool.



**OSAKA T73**

**Tavolo Osaka T73, allungabile syncro, metallo antracite, piano melaminico tavolato Royal Oak 988.  
Sedia City S127, lana antracite.**  
Osaka table T73, syncro extendable, anthracite metal, Royal Oak 988 plank melamine top.  
City chair S127, anthracite wool.





### OSAKA T73

Allungabile full automatic / Full automatic extendable



Allungabile automatico con allunghe laterali simmetriche.

Piani in vetro spess. 12 mm. o Ceramic spess. 13 mm.

Automatically extendable with symmetrical side extensions.

Glass top thk 12 mm or Ceramic top thk 13 mm.

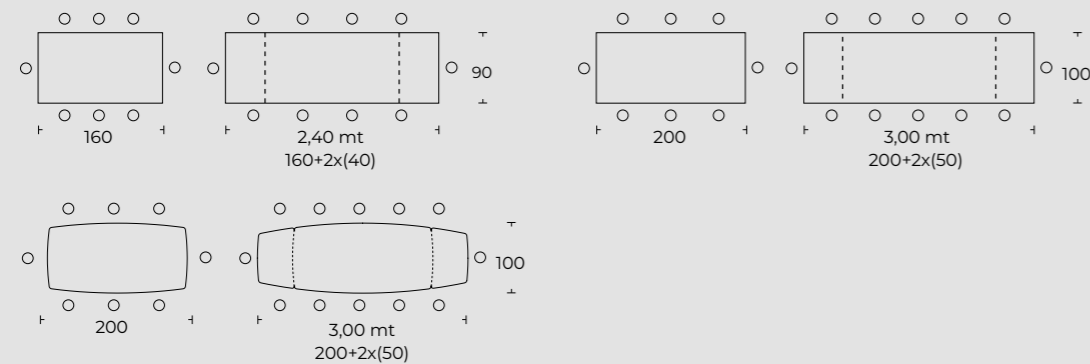

### OSAKA T73

Superallungabile Syncro / Super extendable syncro

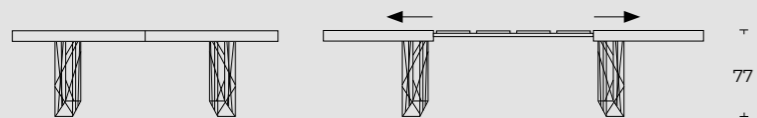

Meccanismo multiprolunghe ad apertura telescopica sincronizzata. Le allunghe sono alloggiare in un apposito scomparto interno. Piano folding impiallacciato in frassino spazzolato o noce americano o in melaminico h 80 mm.

Multiextension mechanism synchronized telescopic opening. The extensions are fitted inside the table. Brushed veneered ash wood or American walnut or melamine folding tops h 80 mm.

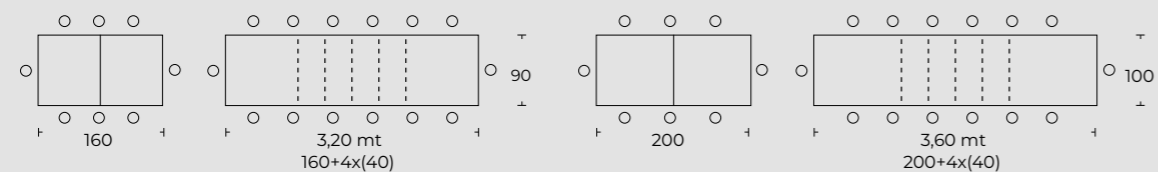

Meccanismo multiprolunghe ad apertura telescopica sincronizzata. Le allunghe sono alloggiare in un apposito scomparto interno. Piano folding impiallacciato in frassino spazzolato h 80 mm.

Multiextension mechanism synchronized telescopic opening. The extensions are fitted inside the table. Brushed veneered ash wood folding top h 80 mm.

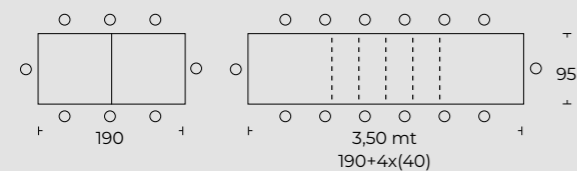

### OSAKA T73

Fisso / Fixed

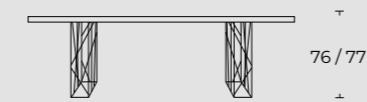

Piano in vetro, ceramic o impiallacciato frassino. / Glass, ceramic or ash wood veneered top.

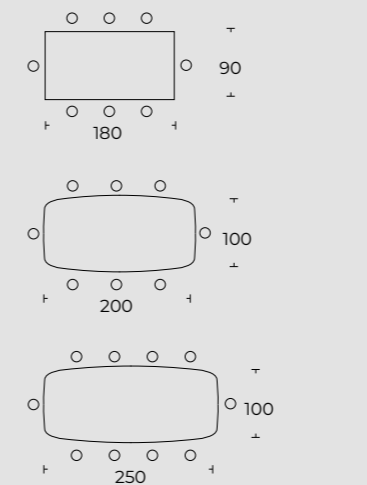

Piano rettangolare in vetro sp.8 mm. o Ceramic sp. 11 mm.  
Rectangular top in glass thk 8 mm or ceramic thk 11 mm.

Piano sagomato in vetro sp. 12 mm, Ceramic sp. 13 mm.  
o impiallacciato in frassino spazzolato sp. 30 mm.  
Shaped top in glass thk 12 mm, ceramic thk 13 mm or  
brushed veneered ash wood thk 30 mm.

Piano sagomato in vetro sp. 12 mm, Ceramic sp. 13 mm.  
o impiallacciato in frassino spazzolato sp. 30 mm.  
Shaped top in glass thk 12 mm, ceramic thk 13 mm or  
brushed veneered ash wood thk 30 mm.

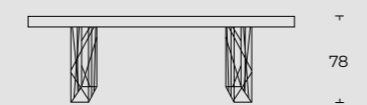

Piano in frassino scortecciato. / Ash wood top with debarked effect.

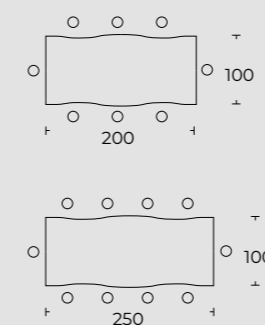

Piano in frassino con effetto scortecciato sp. 45 mm.  
Ash wood top with debarked effect thk 45 mm.

Piano in frassino con effetto scortecciato sp. 45 mm.  
Ash wood top with debarked effect thk 45 mm.

Per le finiture di gambe e piani vedere il campionario My Sample e indicazioni del Listino in vigore.

For the finishings of legs and tops see My Samples collection and indications of price list in effect at the time.





## MIKADO

Design Giuseppe Farinola

**Un sottile e raffinato intreccio volto a richiamare qualche arte lontana, e permettere di creare un sostegno solido ai piani fissi di questo tavolo, laddove potrebbero sembrare impossibili. È come l'antica maestria delle tessiture che vede trasformare in vesti lucenti un semplice e sottile filo di seta, ma che in MIKADO diventa d'acciaio. L'asimmetria nella base è lì per ricordarci che la bellezza si trova anche nell'arte del non identico, in un intreccio diverso eppure luminoso e leggero.**

A subtle and refined interweaving aimed at recalling some distant art, and allowing you to create a solid support for the fixed surfaces of this table, where they might seem impossible. It is like the ancient mastery of weaving that sees a simple and thin thread of silk transforming into shiny garments, which in MIKADO becomes steel. The asymmetry in the base is there to remind us that beauty is also found in the art of the non-identical, in a different but bright and light weave.





**MIKADO T74**

Tavolo Mikado T74, fisso, metallo bianco,  
piano sagomato 250x100 vetro extrabianco lucido VXW.

Sedia City S127, lana azzurra.  
Mikado table T74, fixed, white metal,  
250x100 extrawhite shaped glass top VXW.  
City chair S127, light blue wool.





#### MIKADO T74

Tavolo Mikado T74, fisso, metallo cromato, piano scortecciato sp.45 mm in frassino noce canaletto RV.NC.22. Sedia Cleo S154FR, frassino noce canaletto RV.NC.22, velluto Louvre Mouse.  
 Mikado table T74, fixed, chrome metal, debarked top thk 45mm top in Canaletto walnut RV.NC.22.  
 Cleo chair S154FR, Canaletto walnut RV.NC.22, Mouse Louvre velvet.







#### MIKADO T74

Tavolo Mikado T74, fisso, metallo antracite, piano sagomato 250x100 Ceramic Pietra Grey opaco.  
Sedia Lavinia S158MC, metallo antracite, ecopelle antracite.  
Mikado table T74, fixed, anthracite metal, 250x100 matt Grey Stone Ceramic shaped top.  
Lavinia chair S158MC, anthracite metal, anthracite leatherette.



## MIKADO T74

Tavolo Mikado T74, fisso, piano sagomato 250x100  
impiallacciato noce canaletto RV.NC22.

Sedia Kylian S153MX, metallo antracite, ecopelle antracite.

Mikado table T74, fixed, 250x100

shaped veneered top in Canaletto walnut RV.NC22.

Kylian chair S153MX, anthracite metal, anthracite leatherette.





## MIKADO T74

Tavolo Mikado T74, fisso, metallo antracite, piano sagomato 250x100  
impiallacciato noce canaletto RV.NC22.

Poltrona Demetra S155MX, metallo antracite, lana antracite.

Mikado table T74, fixed, anthracite metal, 250x100  
shaped veneered top in Canaletto walnut Rv.NC22.

Demetra armchair S155MX, anthracite metal, anthracite wool.







### MIKADO T74

Tavolo Mikado T74, fisso, piano sagomato 250x100 Ceramic Pietra Grey opaco.  
Mikado table T74, fixed, 250x100 matt Ceramic Grey Stone shaped top.

### MIKADO T74 Fisso / Fixed

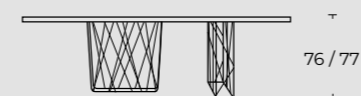

**Piani fissi disponibili in vetro, ceramic o impiallacciato frassino spazzolato.**  
Fixed tops available in glass, ceramic or brushed veneered ash wood.

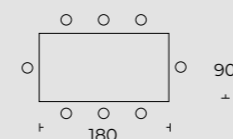

**Piano rettangolare in vetro sp. 8 mm. o Ceramic sp. 11 mm.**  
Rectangular top in glass thk 8 mm or ceramic thk 11 mm.

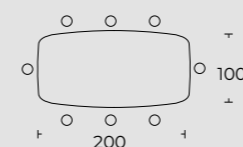

**Piano sagomato in vetro sp. 12 mm. Ceramic sp. 13 mm.  
Impiallacciato in frassino spazzolato sp. 30 mm.**  
Shaped top in glass thk 12 mm, ceramic thk 13 mm  
Brushed veneered ash wood thk 30 mm.

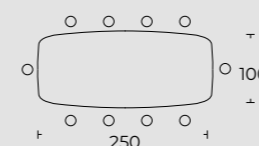

**Piano sagomato in vetro sp. 12 mm. Ceramic sp. 13 mm.  
Impiallacciato in frassino spazzolato sp. 30 mm.**  
Shaped top in glass thk 12 mm, ceramic thk 13 mm  
Brushed veneered ash wood thk 30 mm.

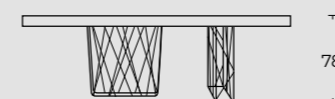

**Piano in frassino scortecciato. / Ash wood top with debarked effect.**

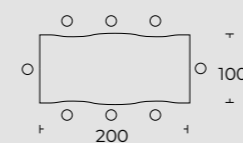

**Piano in frassino con effetto scortecciato sp. 45 mm.**  
Ash wood top with debarked effect thk 45 mm.

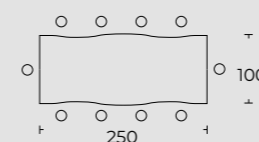

**Piano in frassino con effetto scortecciato sp. 45 mm.**  
Ash wood top with debarked effect thk 45 mm.

**Per le finiture di gambe e piani vedere il campionario My Sample e indicazioni del Listino in vigore.**

For the finishings of legs and tops see My Samples collection and indications of price list in effect at the time.





## MODUS

Design Farinola & Dalmasson

L'ispirazione di un design può diventare talmente complessa che, a volte, non basta una sola voce ad esprimerla. MODUS è un'altra visione del tavolo di design, più versatile e apparentemente leggera, che si integra perfettamente anche in quegli spazi metropolitani che troppo spesso sfidano a sacrificare l'estetica in onore alla praticità. MODUS è una composizione geometrica di incroci, una promessa di leggerezza che pare l'istantanea di un momento, ma è destinata alla stabilità anche nelle possibilità di allungamento del piano e in tutte le sue configurazioni.

The inspiration of a design can become so complex that, sometimes, a single voice is not enough to express it. MODUS is another vision of the design table, more versatile and apparently light, which integrates perfectly even in those metropolitan spaces that too often dare to sacrifice aesthetic in honor of practicality. MODUS is a geometric composition by intersections, a promise of lightness that seems like a snapshot of a moment, but it is intended for stability also in the possibility of top extension as well as in all its configurations.



## MODUS T63

Tavolo Modus T63, allungabile syncro, metallo bianco, piano melaminico tavolato Royal Oak 988.  
Sedia Margie S104V, metallo antracite, ecopelle fango.  
Modus table T63, syncro extendable, white metal,  
Royal Oak 988 plank melamine top.  
Margie chair S104V, anthracite metal, mud leatherette.







### MODUS T63

Tavolo Modus T63, allungabile syncro, metallo antracite, piano melaminico Cemento DA4.  
Sedia Bally S105, metallo antracite, tessuto Queens graphite.  
Modus table T63, syncro extendable, anthracite metal, cement DA4 melamine top.  
Bally chair S105, anthracite metal, graphite Queens fabric.





## MODUS T63

Tavolo Modus T63, allungabile syncro, metallo ottone, piano melaminico Ossido 49H.  
Sedia City S127, tessuto Victoria terracotta.  
Modus table T63, syncro extendable, brass metal, oxide 49H melamine top.  
City chair S127, terracotta Victoria fabric.





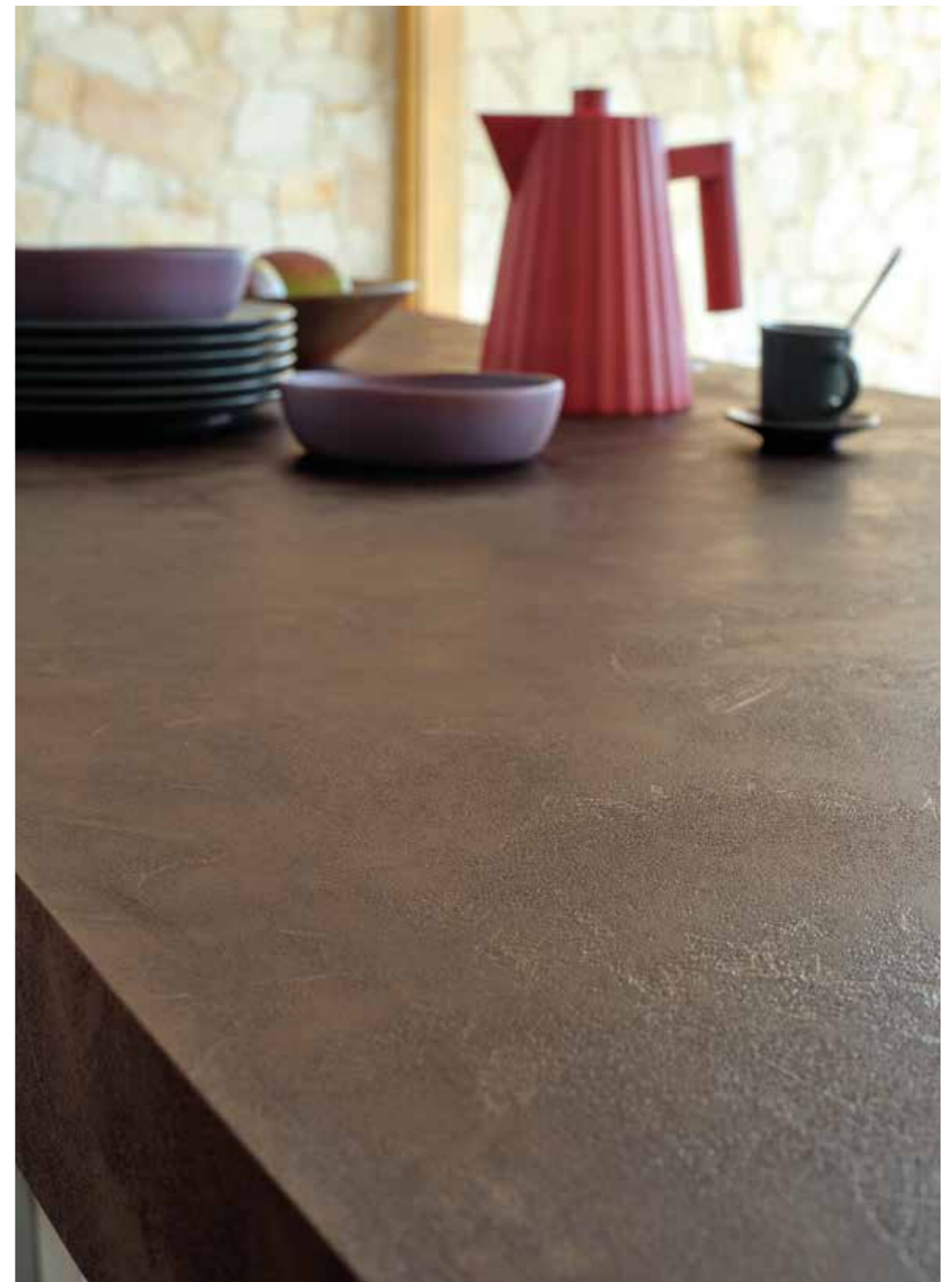

**MODUS T63**

Tavolo Modus T63, allungabile syncro, metallo bicolore, piano melaminico Ossido 49H.  
Sedia Mia S151MT, metallo nero, tessuto Victoria caramel.  
Modus table T63, syncro extendable, bicolor metal, oxide 49H melamine top.  
Mia chair S151MT, black metal, caramel Victoria fabric.





### MODUS T63

Tavolo Modus T63, allungabile syncro, metallo antracite, piano melaminico  
tavolato bianco 34217. Sedia Tracy S130V, metallo antracite, ecopelle antracite.  
Modus table T63, syncro extendable, anthracite metal, white plank 34217 melamine top.  
Tracy chair S130V, anthracite metal, anthracite leatherette.





### MODUS T63

Tavolo Modus T63, allungabile syncro, metallo multicolor smart, piano melaminico calce DC8.  
 Sedia Sandy S108, polipropilene tortora opaco.  
 Modus table T63, syncro extendable, multicolor metal, lime melamine top DC8.  
 Sandy chair S108, matt taupe polypropylene.





MODUS T63

Tavolo Modus T63, allungabile syncro, metallo multicolor smart,  
piano melaminico malta antracite 34321.  
Sedia Margie S104V, metallo antracite, tessuto Queens taupe.  
Modus table T63, syncro extendable, smart multicolor metal,  
anthracite mortar melamine top 34321.  
Margie chair S104V, anthracite metal, taupe Queens fabric.







### MODUS T63

Tavolo Modus T63, allungabile syncro, metallo multicolor smart, piano melaminico malta antracite 34321.

Modus table T63, syncro extendable, smart multicolor metal, anthracite mortar 34321 melamine top.

### MODUS T63

Superallungabile Syncro / Super extendable syncro

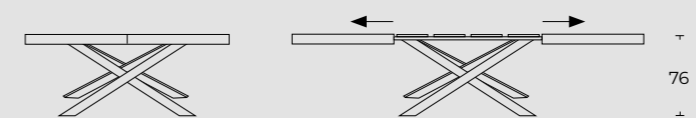

Meccanismo multiprolonghe ad apertura telescopica sincronizzata. Le allunghe sono alloggiare in un apposito scomparto interno.

Piano folding h 80 mm impiallacciato in frassino spazzolato o in melaminico.

Multiextension mechanism with synchronized telescopic opening. The extensions are fitted inside the table. Brushed veneered ash wood or melamine top h 80 mm.

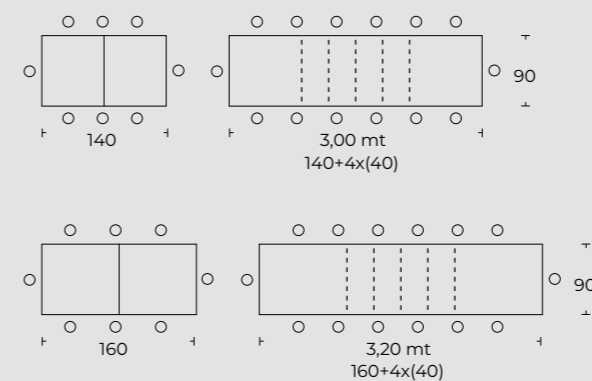

Per le finiture di gambe e piani vedere il campionario My Sample e indicazioni del Listino in vigore.

For the finishings of legs and tops see My Samples collection and indications of price list in effect at the time.



# Il privilegio della possibilità.

IL PRIVILEGIO DELLA POSSIBILITÀ. QUANDO CI CONFRONTIAMO CON DEGLI AMBIENTI NUOVI ABBIAMO IL PRIVILEGIO DELLA POSSIBILITÀ: UN FOGLIO BIANCO SU CUI INVENTARE NUOVE PROPORZIONI. CI SONO TANTI MODI PER COMPRENDERE GLI SPAZI. POSSIAMO DECIDERE COME GESTIRLI E SUDDIVIDERLI, SE ASSEGNARE UNA FUNZIONE SPECIALE A CIASCUNA ZONA OPPURE LASCIARE CHE L'ENERGIA SCORRA LIBERA ATTRAVERSO GLI ELEMENTI CHE LI ABITANO. I TAVOLI DELLA COLLEZIONE FRIULSEDIE EXTENSA SONO VIVI E VITALI, CON LA LORO CAPACITÀ DI ALLUNGAMENTO CHE, PROPRIO COME UN RESPIRO, LI FA ARRIVARE AD AMPLIFICARE LO SPAZIO O A CONTRARSI NEL MASSIMO DELLA NECESSITÀ. PER POI RIAPRIRSI AGILI, FACILI E CON POCHI GESTI, E SOPRATTUTTO LASCIANDO INTATTO IL GUSTO DI UN DESIGN SEMPRE IMPECCABILE, COME TUTTI I TAVOLI FRIULSEDIE. LE MOLTEPLICI VARIAZIONI SUL TEMA DEL PIANO SONO LA CIFRA DISTINTIVA DI EXTENSA CHE, ACCANTO ALLA SELEZIONE DEI MATERIALI, OFFRE UNA SCELTA DI ESPANSIONE A PROLUNGHE UNICHE O A PIÙ SEGMENTI. LE QUASI TREMILA CONFIGURAZIONI DELLA COLLEZIONE EXTENSA APRONO ALLO SVILUPPO DI UN DESIGN CHE INTEGRA ELEGANTEMENTE UN LIVING POLIEDRICO COME ANCHE UNA CUCINA DAGLI SPUNTI IMPORTANTI.

THE PRIVILEGE OF POSSIBILITY. WHEN WE COME INTO CONTACT WITH NEW ENVIRONMENTS WE HAVE THE PRIVILEGE OF POSSIBILITY: A WHITE SHEET ON WHICH TO INVENT NEW PROPORTIONS. THERE ARE MANY WAYS TO CONCEIVE SPACES. WE CAN DECIDE HOW TO MANAGE AND DIVIDE THEM, WHETHER TO ASSIGN A SPECIAL FUNCTION TO EACH ZONE OR LET THE ENERGY FLOW FREELY THROUGH THE ELEMENTS THAT INHABIT THEM. THE TABLES OF THE EXTENSA COLLECTION ARE ALIVE AND VITAL WITH THEIR STRETCHING ABILITY THAT - JUST LIKE A BREATH - CAUSES THEM TO AMPLIFY THE SPACE OR CONTRACT AT THE MAXIMUM OF NECESSITY. THEN THEY REOPEN NIMBLY, EASILY AND WITH A FEW GESTURES AND, ABOVE ALL, LEAVING INTACT THE TASTE OF A DESIGN THAT IS ALWAYS IMPECCABLE. LIKE ALL FRIULSEDIE TABLES. THE MULTIPLE VARIATIONS ON THE THEME OF THE TOP ARE THE DISTINCTIVE FACTOR OF EXTENSA WHICH, ALONGSIDE THE SELECTION OF MATERIALS, OFFERS A CHOICE OF EXPANSION WITH SINGLE OR MULTI-SEGMENT EXTENSIONS. THE NEARLY THREE THOUSAND CONFIGURATIONS OF THE EXTENSA COLLECTION OPEN TO THE DEVELOPMENT OF A DESIGN THAT ELEGANTLY INTEGRATES A MULTIFACETED LIVING ROOM AS WELL AS A KITCHEN WITH IMPORTANT IDEAS.

# EXTENSA

COLLEZIONE





## LEVANTE

Design Giuseppe Farinola

Ogni prospettiva differente rivela la natura trompe-l'oeil di questo tavolo. C'è un gioco di movimento continuo che va oltre le molteplici possibilità di apertura ed espansione, sviluppando la visione ideale del tavolo anche in altezza e profondità. I piani sono liberi di estendersi, mentre la consistenza metallica delle sue gambe si proietta obliqua e sicura verso il basso, LEVANTE è pensato per destrutturare l'ordinaria visione del razionale.

Each different perspective reveals the trompe-l'oeil nature of this table. There is a game of continuous movement that goes beyond the multiple possibilities of opening and expansion, developing the ideal view of the table also in height and depth. The tops are free to extend, while the metal texture of its legs is projected obliquely and confidently downwards. LEVANTE is designed to deconstruct the ordinary vision of the rational.



## LEVANTE T54

Tavolo Levante T54, metallo titanio, piano Ceramic Sahara Noir bocciardato.  
Sedia Sasha S150MT, metallo titanio, tessuto Victoria june bug.  
Levante table T54, titanium metal, bush-hammered Sahara Noir Ceramic top.  
Sasha chair S150MT, titanium metal, june bug Victoria fabric.





**LEVANTE T54**

Tavolo Levante T54, metallo titanio, piano Ceramic Emperador Lucido.  
Sedia Gea S164MC, metallo titanio, tessuto Victoria elephant.  
Levante table T54, titanium metal, glossy Emperador Ceramic top.  
Gea chair S164MC, titanium metal, elephant Victoria fabric.





#### LEVANTE T54

Tavolo Levante T54, metallo bianco, piano Ceramic Invisible White opaco.  
Sedia Gea S164MC, metallo oro antico, tessuto Victoria elephant.  
Levante table T54, white metal, matt Invisible White Ceramic top.  
Gea chair S164MC, antique gold metal, elephant Victoria fabric.





#### LEVANTE T54

Tavolo Levante T54, metallo antracite, piano melaminico cemento DA4.  
Sedia Margie S104V, metallo antracite, tessuto Queens petrol.  
Levante table T54, anthracite metal, cement DA4 melamine top.  
Margie chair S104V, anthracite metal, petrol Queens fabric.



## LEVANTE T54

Tavolo Levante T54, metallo ottone, piano Ceramic Calacatta lucido.  
Sedia Mia S151MT, metallo ottone, tessuto Victoria caramel.  
Levante table T54, fixed, brass metal, glossy Calacatta Ceramic top.  
Mia chair S151MT, brass metal, caramel Victoria fabric.





## LEVANTE T54

Allungabile telescopico con maxi allunga / Telescopic extendable with maxi extension

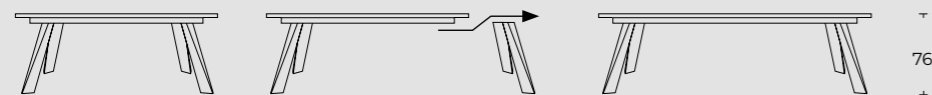

Il meccanismo si allunga consentendo l'inserimento di una maxi allunga a libro integrata nella struttura. Piano rettangolare in vetro sp.8 mm o Ceramic sp.11 mm  
The telescopic mechanism extends allowing insertion of a hinged maxi extension integrated into the frame. Rectangular top in glass thk 8 mm or Ceramic thk 11 mm.

### MAXXI 140

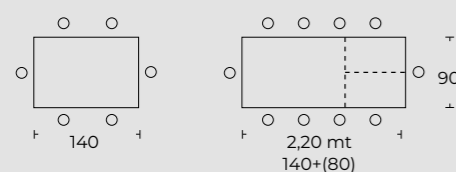

### MAXXI 160

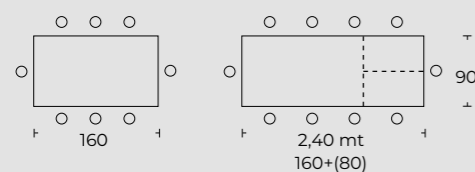

### MAXXI 180

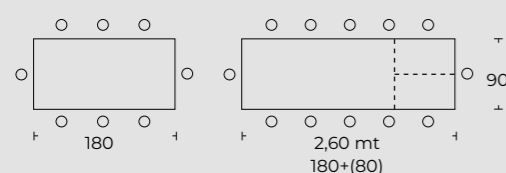

## LEVANTE T54

Superallungabile telescopico / Super extendable telescopic

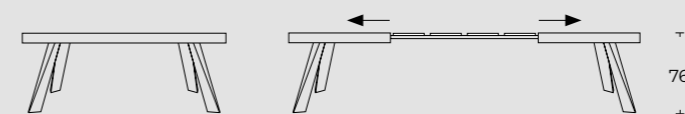

Meccanismo multiprolunghe ad apertura telescopica. Le allunghe sono alloggiare in un apposito scomparto interno.

Multiextension mechanism with telescopic opening. The extensions are fitted inside the table.

### FOLDING DUO 140

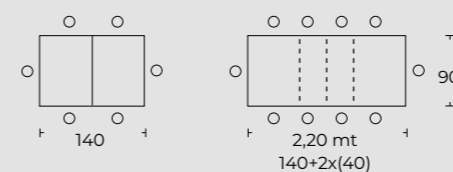

### FOLDING DUO 160

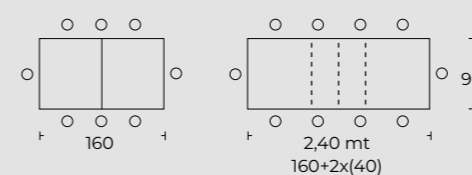

### FOLDING 160

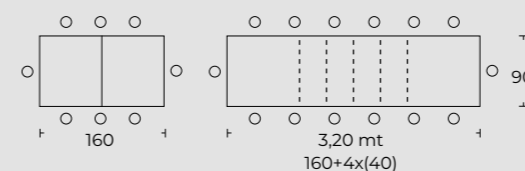

### FOLDING 190

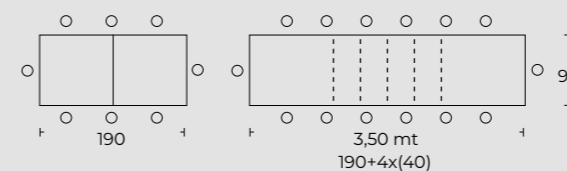

### FOLDING 200

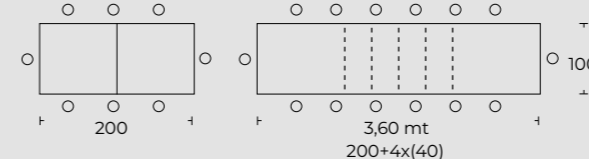

Piano folding H 80 mm impiallacciato tinto o laccato, melaminico.

Folding top h 80mm veneered dyed or lacquered, melamine.

Piano folding H 80 mm impiallacciato tinto o laccato, melaminico.

Folding top h 80mm veneered dyed or lacquered, melamine.

Piano folding H 80 mm impiallacciato tinto o laccato, melaminico.

Folding top h 80mm veneered dyed or lacquered, melamine.

Piano folding H 80 mm Impiallacciato tinto o laccato.

Folding top h 80mm veneered dyed or lacquered.

Piano folding H 80 mm melaminico.

Folding top h 80mm melamine.

Per le finiture di gambe e piani vedere il campionario My Sample e indicazioni del Listino in vigore.

For the finishings of legs and tops see My Samples collection and indications of price list in effect at the time.





## DENVER

Design Farinola & Dalmasson

Eleganza e stile si incontrano letteralmente attorno a un tavolo. DENVER è un'idea di base, un concetto che prende gli elementi che compongono un tavolo allungabile di design e li rende sempre accessibili ed integrabili. La scelta dei materiali di questo tavolo è in grado di rendere ogni volta uno spirito completamente nuovo, quando i riflessi metallici o la rassicurante essenza del legno interagiscono ecletticamente con l'ingegnosa inclinazione delle gambe, puntate verso l'esterno e proiettate ad un vertice ideale al di sopra del piano, che sembra tagliare questa piramide immaginaria.

Elegance and style literally meet around a table. DENVER is a basic idea, a concept that takes the elements that make up a design extendable table and makes them always accessible and integrable. The choice of materials of this table is able to always make it a completely new spirit, when the metal reflections or the reassuring essence of the wood interact eclectically with the ingenious inclination of the legs, pointing towards the outside and projected to an ideal vertex above the top, which seems to cut this imaginary pyramid.



## DENVER T52

Tavolo Denver T52, metallo ottone, piano melaminico ossido 49H.  
Sedia Sasha S150MT, metallo ottone, tessuto Victoria june bug.  
Denver table T52, brass metal, oxide 49H melamine top.  
Sasha chair S150MT, brass metal, June bug Victoria fabric.





**DENVER T52**

Tavolo Denver T52, metallo ottone, piano Melaminico Ossido 49H.  
Sedia Sasha S150MT, metallo ottone, tessuto june bug.  
Denver table T52, brass metal, oxide 49H melamine top.  
Sasha chair S150MT, brass metal, June bug Victoria fabric.





## DENVER T52

Tavolo Denver T52, metallo antracite, piano melaminico tavolato Royal Oak 988.  
Sedia Margie S104V, metallo antracite, tessuto Queens brown.

Denver table T52, anthracite metal, Royal Oak 988 plank melamine top.  
Margie chair S104V, anthracite metal, brown Queens fabric.



## DENVER T52

Tavolo Denver T52, piano melaminico tavolato Royal Oak 988.

Sedia Cleo S154FR, lana grigio chiaro.

Denver table T52, plank Royal Oak 988 top.  
Cleo chair S154FR, light grey wool.







## DENVER T52

Tavolo Denver T52, metallo nero, piano Ceramic Sahara Noir bocciardato.  
Sedia Mia S151MX, metallo nero, tessuto Victoria caramel.

Denver table T52, black metal, bush-hammered Sahara Noir Ceramic top.  
Mia chair S151MX, black metal, caramel Victoria fabric.





### DENVER T52

Tavolo Denver T52, metallo titanio, piano vetro velvet opaco tortora A.V.T.  
Sedia Tracy S130V, metallo titanio, tessuto Queens taupe.  
Denver table T52, titanium metal, matt taupe A.V.T. glass top.  
Tracy chair S130V, titanium metal, taupe Queens fabric.





**DENVER T52**

Tavolo Denver T52, metallo bianco, piano noce americano N.26.  
Sedia Gran Manon S141FR (pag. 200), frassino laccato bianco, rigenerato di cuoio bianco.  
Denver table T52, white metal. American walnut top N.26.  
Gran Manon chair S141FR (page 200), lacquered white ash wood, white regenerated leather.



## DENVER T52

Allungabile telescopico con maxi allunga / Telescopic extendable with maxi extension

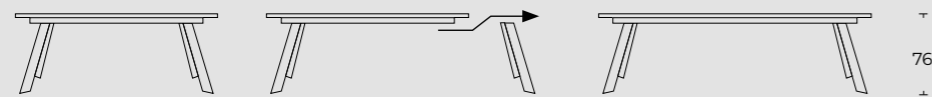

Il meccanismo si allunga consentendo l'inserimento di una maxi allunga a libro integrata nella struttura. Piano rettangolare in vetro sp.8 mm o Ceramic sp.11 mm

The telescopic mechanism extends allowing insertion of a hinged maxi extension integrated into the frame. Rectangular top in glass thk 8 mm or Ceramic thk 11 mm.

### MAXXI 140

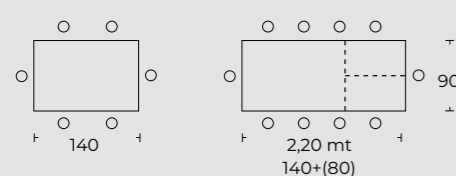

### MAXXI 160

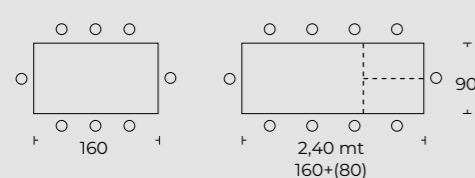

### MAXXI 180

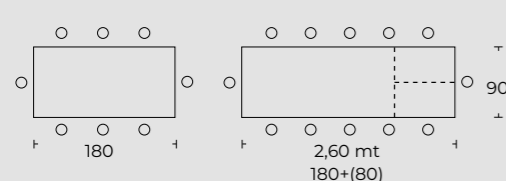

## DENVER T52

Superallungabile telescopico / Super extendable telescopic

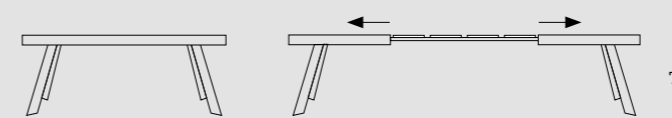

Meccanismo multiprolunghe ad apertura telescopica. Le allunghe sono alloggiare in un apposito scomparto interno.

Multiextension mechanism with telescopic opening. The extensions are fitted inside the table.

### FOLDING DUO 140

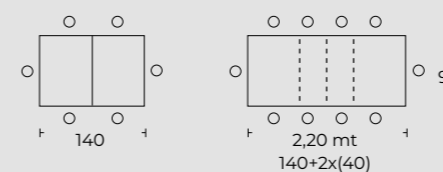

### FOLDING DUO 160

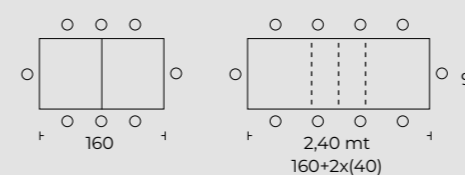

### FOLDING 160

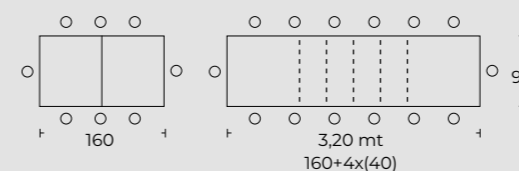

### FOLDING 190

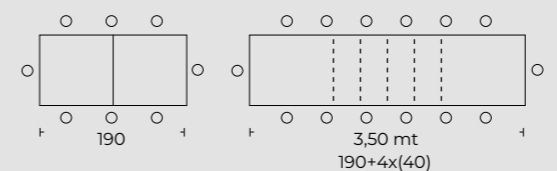

### FOLDING 200

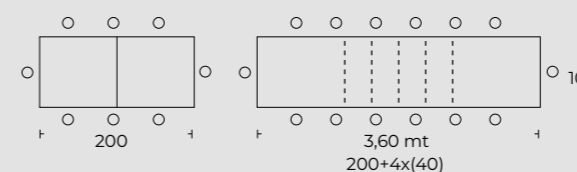

Piano folding H 80 mm impiallacciato tinto o laccato, melaminico.

Folding top h 80mm veneered dyed or lacquered, melamine.

Piano folding H 80 mm impiallacciato tinto o laccato, melaminico.

Folding top h 80mm veneered dyed or lacquered, melamine.

Piano folding H 80 mm impiallacciato tinto o laccato, melaminico.

Folding top h 80mm veneered dyed or lacquered, melamine.

Piano folding H 80 mm Impiallacciato tinto o laccato.

Folding top h 80mm veneered dyed or lacquered.

Piano folding H 80 mm melaminico.

Folding top h 80mm melamine.

Per le finiture di gambe e piani vedere il campionario My Sample e indicazioni del Listino in vigore.

For the finishings of legs and tops see My Samples collection and indications of price list in effect at the time.





## PEGASO

Design Farinola & Dalmasson

**Nelle linee di PEGASO si trova la dinamicità di una silhouette slanciata, con le possibilità di espansione di un piano che si proietta in lunghezza. E verso l'alto protendono le gambe, che sono proprio come quelle del cavallo alato. In questo, PEGASO non è soltanto un mito: sembra che siano pronte a spiccare il volo in un impeto di levità. Eppure l'insieme è così forte e saldo che riporta alla realtà dell'ambiente in cui si colloca, sia esso living o kitchen.**

The dynamism of a slender silhouette is found in the lines of PEGASO, with the possibilities of expansion of a top that is projected in length. And its legs stretch out upwards, just like those of the winged horse. In this, PEGASO is not just a myth: it seems that they are ready to take flight in a rush of levity. Yet the whole is so strong and firm that it leads back to the reality of the environment in which it is located, be that the living room or the kitchen.



**PEGASO T53**

Tavolo Pegaso T53, metallo antracite, piano malta tortora AP2.  
Sedia Brenda S102, tessuto Queens graphite.  
Pegaso table T53, anthracite metal, taupe mortar melamine top AP2.  
Brenda chair S102, graphite Queens fabric.







**PEGASO T53**

Tavolo Pegaso T53, metallo antracite, piano melaminico malta tortora AP2.  
Sedia Brenda S102, tessuto Queens graphite.  
Pegaso table T53, anthracite metal, taupe mortar melamine top AP2.  
Brenda chair S102, graphite Queens fabric.





### PEGASO T53

Tavolo Pegaso T53, metallo ottone, piano Ceramic Fokos Nero opaco.  
Sedia Tracy S130V, metallo ottone, tessuto Queens graphite.  
Pegaso table T53, brass metal, matt black Fokos Ceramic top.  
Tracy chair S130V, brass metal, graphite Queens fabric.



## PEGASO T53

Tavolo Pegaso T53, metallo nero, piano Ceramic Noir Desir lucido.  
Sedia City S127, tessuto Victoria gold.  
Pegaso table T53, black metal, glossy Noir Desir Ceramic top.  
City chair S127, gold Victoria fabric.





## PEGASO T53

Tavolo Pegaso T53, piano Ceramic Noir Desir lucido.

Sedia City S127, tessuto Victoria caramel, terracotta, gold, lizard green.

Pegaso table T53, glossy Noir Desir Ceramic top.

City chair S127, caramel, terracotta, gold, lizard green Victoria fabric.





## PEGASO T53

Allungabile telescopico con maxi allunga / Telescopic extendable with maxi extension

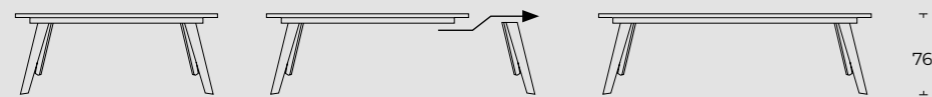

Il meccanismo si allunga consentendo l'inserimento di una maxi allunga a libro integrata nella struttura. Piano rettangolare in vetro sp.8 mm o Ceramic sp.11 mm

The telescopic mechanism extends allowing insertion of a hinged maxi extension integrated into the frame. Rectangular top in glass thk 8 mm or Ceramic thk 11 mm.

### MAXXI 140

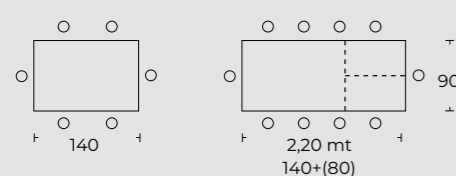

### MAXXI 160

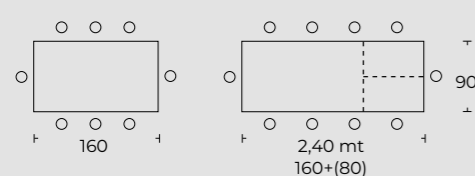

### MAXXI 180

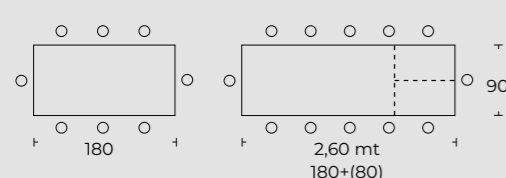

## PEGASO T53

Superallungabile telescopico / Super extendable telescopic

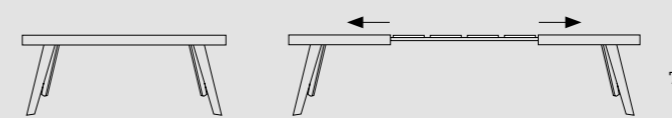

Meccanismo multiprolunghe ad apertura telescopica. Le allunghe sono alloggiare in un apposito scomparto interno.

Multiextension mechanism with telescopic opening. The extensions are fitted inside the table.

### FOLDING DUO 140

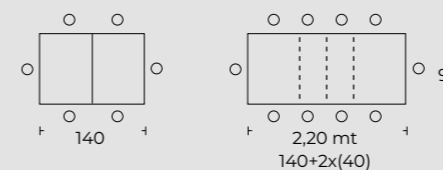

### FOLDING DUO 160

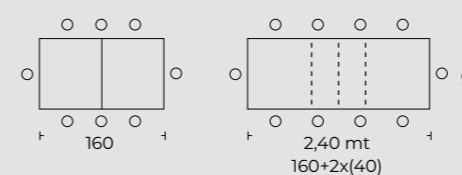

### FOLDING 160

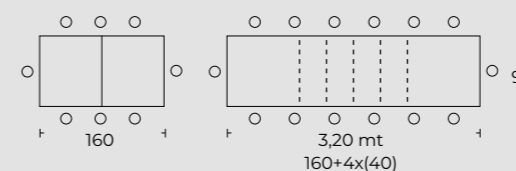

### FOLDING 190

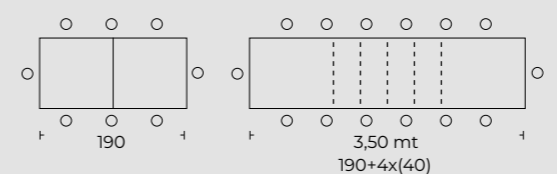

### FOLDING 200

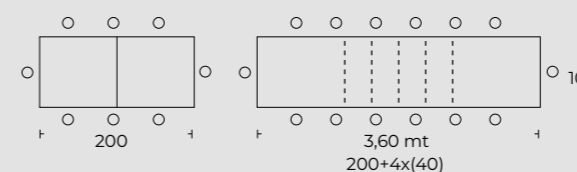

Piano folding H 80 mm impiallacciato tinto o laccato, melaminico.

Folding top h 80mm veneered dyed or lacquered, melamine.

Piano folding H 80 mm impiallacciato tinto o laccato, melaminico.

Folding top h 80mm veneered dyed or lacquered, melamine.

Piano folding H 80 mm impiallacciato tinto o laccato, melaminico.

Folding top h 80mm veneered dyed or lacquered, melamine.

Piano folding H 80 mm Impiallacciato tinto o laccato.

Folding top h 80mm veneered dyed or lacquered.

Piano folding H 80 mm melaminico.

Folding top h 80mm melamine.

Per le finiture di gambe e piani vedere il campionario My Sample e indicazioni del Listino in vigore.

For the finishings of legs and tops see My Samples collection and indications of price list in effect at the time.





## MEMPHIS

Design Farinola & Dalmasson

È il tavolo di una ricerca che parte dalla semplicità di un incrocio e si estende nell'ambiente, in tutte le sue possibilità di apertura, per esaltarne l'importanza. Le gambe di MEMPHIS sono precisamente quel segno che traccia il punto in cui arrivare e fermarsi, nella geografia della casa. La modernità del progetto vede MEMPHIS come ospite speciale di un living, ma che sa elevare un ambiente kitchen a nuovi e ricercati momenti di condivisione attorno al desco.

It is the table of a research that starts from the simplicity of an intersection and extends into the environment, in all its opening possibilities, to emphasize its importance. MEMPHIS' legs are precisely the sign that detects the point to arrive and stop, in the geography of the house. The modernity of the project sees MEMPHIS as a special guest of a living room, which knows how to elevate a kitchen environment to new and refined moments of sharing around the table.



## MEMPHIS T51

Tavolo Memphis T51, metallo ottone, piano melaminico malta tortora AP2.  
Sedia Vanilla S167, metallo ottone, tessuto Victoria lizard green.  
Memphis table T51, brass metal, taupe mortar melamine top AP2.  
Vanilla chair S167, brass metal, lizard green Victoria fabric.







## MEMPHIS T51

Tavolo Memphis T51, metallo bianco, piano Noce Americano N.26.  
Sedia Gran Manon S141FR, frassino laccato bianco, rigenerato di cuoio bianco.  
Memphis table T51, white metal, American walnut top N.26.  
Gran Manon chair S141FR, lacquered white ash wood, white regenerated leather.



## MEMPHIS T51

Tavolo Memphis T51, metallo antracite, piano Noce Americano N.26.  
Sedia Tracy S130V, metallo antracite, ecopelle antracite.  
Memphis table T51, anthracite metal, American walnut top N.26.  
Tracy chair S130V, anthracite metal, anthracite leatherette.







## MEMPHIS T51

Tavolo Memphis T51, metallo antracite, carter inox lucido, piano noce Americano N.26.  
Sedia Tracy S130V, metallo antracite, ecopelle antracite.  
Memphis table T51, anthracite metal, glossy stainless carter, American walnut top N.26.  
Tracy chair S130V, anthracite metal, anthracite leatherette.

## MEMPHIS T51

Superallungabile telescopico / Super extendable telescopic

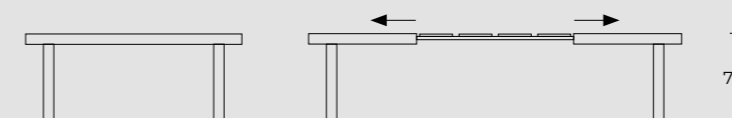

**Meccanismo multiprolunghe ad apertura telescopica. Le allunghe sono alloggiate in un apposito scomparto interno.**

Multiextension mechanism with telescopic opening. The extensions are fitted inside the table.

### FOLDING 160

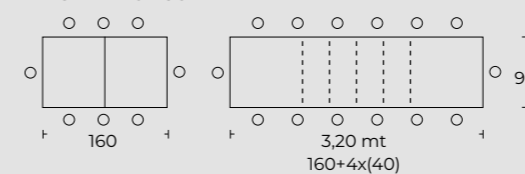

**Piano folding H 80 mm impiallacciato tinto o laccato, melaminico.**

Folding top h 80mm veneered dyed or lacquered, melamine.

### FOLDING 190

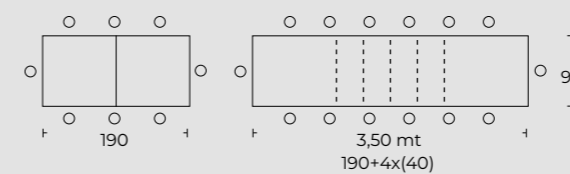

**Piano folding H 80 mm Impiallacciato tinto o laccato.**

Folding top h 80mm veneered dyed or lacquered.

### FOLDING 200

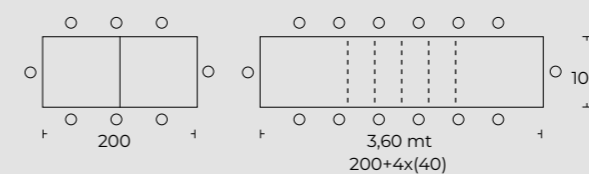

**Piano folding H 80 mm melaminico.**

Folding top h 80mm melamine.

**Per le finiture di gambe e piani vedere il campionario My Sample e indicazioni del Listino in vigore.**

For the finishings of legs and tops see My Samples collection and indications of price list in effect at the time.



# L'infinito è l'unico limite.

L'INFINITO È L'UNICO LIMITE. IL CONCEPT DA CUI NASCE LA COLLEZIONE DI TAVOLI INFINITY FRIULSEDIE È PENSARE A UN TAVOLO SUPERANDO IL LIMITE DELL'AMBIENTE PER CUI LO SI SCEGLIE. LE ARCHITETTURE CONTEMPORANEE HANNO VISTO DISSOLVERSI LE PARETI IN AMBIENTI FLUIDI, CHE VENGONO VISSUTI IN MANIERA MULTIFUNZIONALE. L'AVVENTURA DI QUESTA COLLEZIONE È COMPORRE TAVOLI CHE SODDISFINO IL DESIDERIO DI UN OCCHIO ESIGENTE E DI UNO STILE ECLETTICO, CHE SAPPIANO ESSERE DUTTILI E ACCOGLIENTI, MA AL TEMPO STESSO ESPRESSIONE DI STABILITÀ E DURATA NEL TEMPO. È UNA SFIDA A PENSARE FUORI DALLE CASELLE DELL'ABITUDINE. I SISTEMI TELESCOPICI CUSTODITI NEL CUORE DI QUESTA COLLEZIONE GENERANO PIANI ALLUNGABILI A PIACERE - FINO A OLTRE TRE METRI - E SI COMBINANO A SUPERFICI, FINITURE E VARIAZIONI CROMATICHE IN OLTRE CINQUEMILA DIVERSE CONFIGURAZIONI. UN TAVOLO INFINITY DIVENTA IL LIVING E DIVENTA LA CUCINA. O, ANCORA: UN TAVOLO INFINITY TRASFORMA CIASCUN LUOGO IN QUELLO CHE SI VUOLE, SI IMMAGINA, SI CREA.

INFINITY IS THE ONLY LIMIT. THE CONCEPT FROM WHICH THE INFINITY TABLES COLLECTION STEMS FROM IS TO THINK OF A TABLE SURPASSING THE LIMIT OF THE ENVIRONMENT IT IS CHOSEN FOR. CONTEMPORARY ARCHITECTURES HAVE SEEN WALLS DISSOLVING IN FLUID ENVIRONMENTS, WHICH ARE EXPERIENCED IN A MULTIFUNCTIONAL WAY. THE ADVENTURE OF THIS COLLECTION IS TO MAKE TABLES THAT SATISFY THE DESIRE OF A DISCERNING EYE AND AN ECLECTIC STYLE, WHICH KNOW HOW TO BE FLEXIBLE AND WELCOMING, YET COINCIDENTLY AN EXPRESSION OF STABILITY AND DURABILITY OVER TIME. IT IS A CHALLENGE TO THINK OUT OF THE BOX. THE TELESCOPIC SYSTEMS KEPT IN THE HEART OF THIS COLLECTION GENERATE TOPS THAT CAN BE EXTENDED AS DESIRED - UP TO OVER THREE METERS - WHICH COMBINE WITH SURFACES, FINISHES AND COLOR VARIATIONS IN MORE THAN FIVE THOUSAND DIFFERENT CONFIGURATIONS. AN INFINITY TABLE BECOMES THE LIVING ROOM AND BECOMES THE KITCHEN. OR STILL: AN INFINITY TABLE TRANSFORMS EACH PLACE IN WHAT ONE WANTS, IMAGINES AND CREATES.

# INFINITY

COLLEZIONE





## SPENCER

Design Farinola & Dalmasson

La linea che staglia il design di questo tavolo è un profilo netto, deciso. Ben oltre il mero aspetto della funzionalità, si tratta di un oggetto impeccabile nell'orizzonte domestico. Sia gli spazi kitchen sia i living trovano in ciascuna delle espressioni configurabili di SPENCER una corrispondenza sempre ricercata nei dettagli e rassicurante, grazie alle sue possibilità di espansione e alle selezioni materiche del piano.

The line that stands out in the design of this table is a clean, decisive profile. Far beyond mere appearance of functionality, it is an impeccable object on the domestic horizon. Both the kitchen and living spaces find in each of SPENCER's configurable expressions a more and more reassuring and refined correspondence in detail thanks to its possibilities of expansion and material selections of the top.



## SPENCER T87

Tavolo Spencer T87, metallo ottone, piano Ceramic Fokos Roccia opaco.  
Sedia Tracy S130V, metallo ottone, tessuto Queens taupe.  
Spencer table T87, brass metal, matt rock Fokos Ceramic top.  
Tracy chair S130V, brass metal, taupe Queens fabric.







### SPENCER T87

Tavolo Spencer T87, metallo nero, piano Ceramic Sahara Noir bocciardato.  
Sedia Gran Manon S141MT, metallo nero, rigenerato di cuoio cognac.  
Spencer table T87, black metal, bush-hammered Sahara Noir Ceramic top.  
Gran Manon chair S141MT, black metal, cognac regenerated leather.





### SPENCER T87

Tavolo Spencer T87, metallo nero, piano impiallacciato Royal Oak RV.RO.38.  
Sedia Shell S149MT, metallo nero, multistrati laccato nero.  
Spencer table T87, black metal, Royal Oak RV.RO.38 veneered top.  
Shell chair S149MT, black metal, black lacquered plywood seat.







### SPENCER T87

Tavolo Spencer T87, metallo antracite, piano melaminico cemento DA4.  
Sedia Fanny S152MT, metallo antracite, tessuto econabuk ardesia.  
Spencer table T87, anthracite metal, cement DA4 melamine top.  
Fanny chair S152MT, anthracite metal, ardesia econabuk.



SPENCER T87

Tavolo Spencer T87, metallo titanio, piano Ceramic Emperador lucido.  
Sedia Mia S151MT, metallo titanio, tessuto Victoria elephant.  
Spencer table T87, titanium metal, glossy Emperador Ceramic top.  
Mia chair S151MT, titanium metal, elephant Victoria fabric.



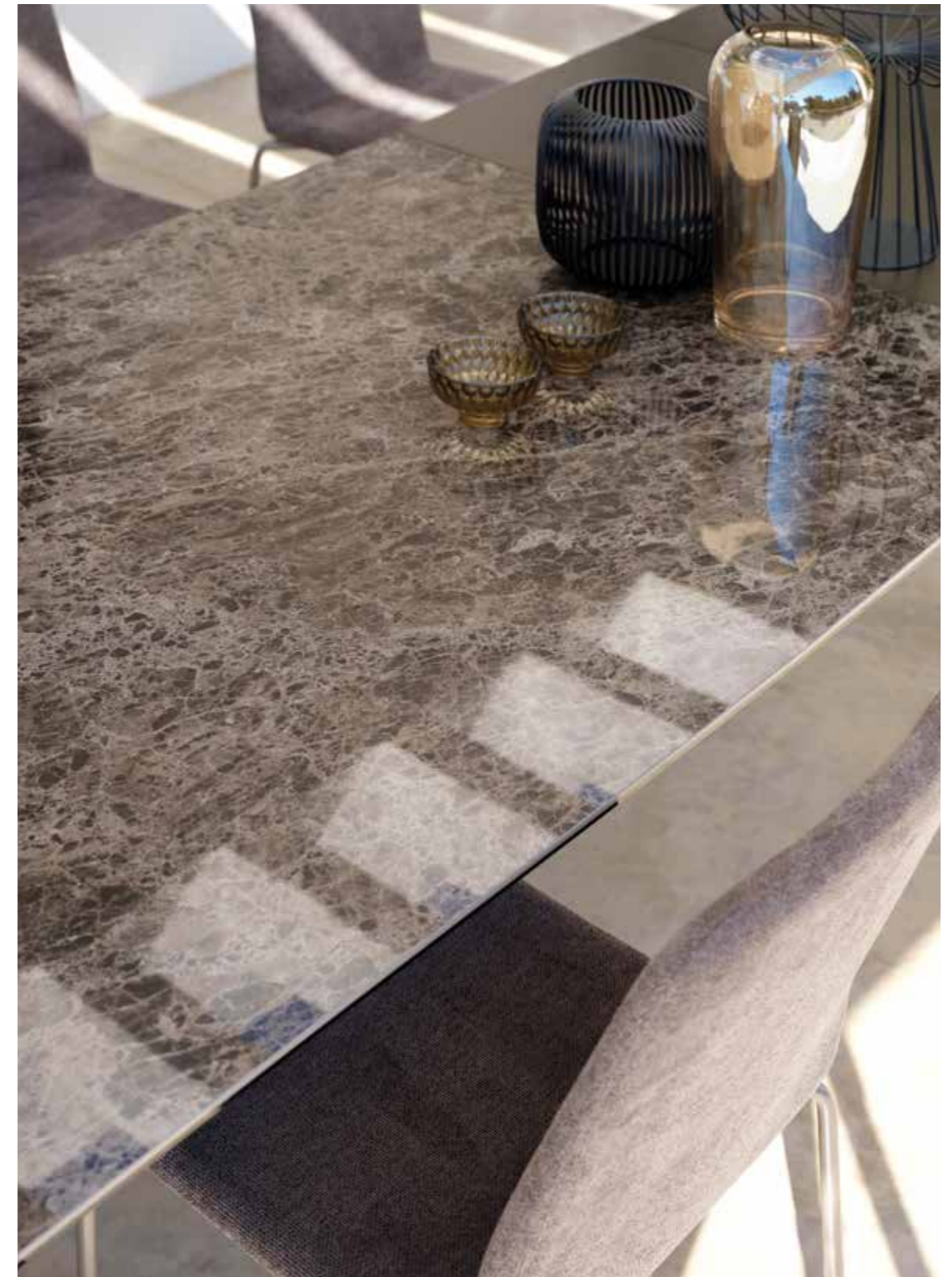

**SPENCER T87**

Tavolo Spencer T87, metallo titanio, piano Ceramic Emperador Lucido.  
Sedia Mia S151MT, metallo titanio, tessuto Victoria elephant.  
Spencer table T87, titanium metal, glossy Emperador Ceramic top.  
Mia chair S151MT, titanium metal, elephant Victoria fabric.





### SPENCER T87

Tavolo Spencer T87, metallo antracite, piano Ceramic Noir Desir lucido.  
Spencer table T87, anthracite metal, glossy Noir Desir Ceramic top.

### SPENCER T87

Superallungabile telescopico / Super extendable telescopic

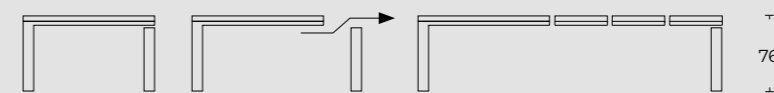

Il meccanismo si allunga consentendo l'inserimento manuale e progressivo di allunghe ad incastro. Le allunghe sono alloggiare in un apposito scomparto interno.  
Piano rettangolare in vetro sp.8 mm, ceramic sp.11 mm, impiallacciato sp.20mm, melaminico sp.19mm

The telescopic frame allows manual and progressive insertion of extensions. The extensions are fitted inside the table.

Rectangular top in glass thk 8 mm, Ceramic thk 11 mm, veneered thk 20 mm or melamine thk 19 mm.

#### PLUS

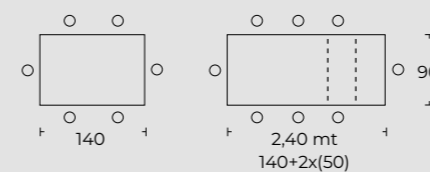

#### SUPER

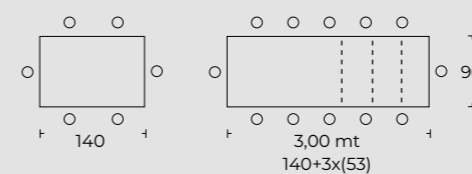

#### DOUBLE

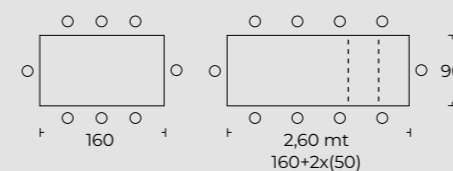

#### ULTRA

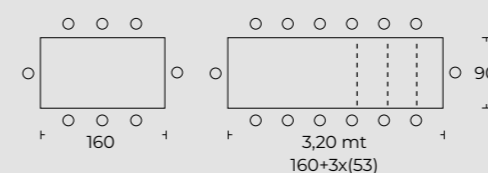

#### TOP

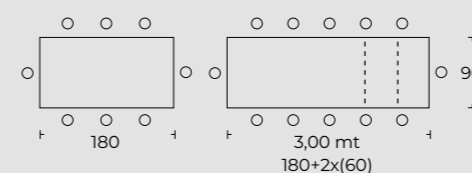

Per le finiture di gambe e piani vedere il campionario My Sample e indicazioni del Listino in vigore.

For the finishings of legs and tops see My Samples collection and indications of price list in effect at the time.





## CARTESIO

Design Farinola & Dalmasson

**Le coordinate dello spazio cambiano all'allungarsi del piano di CARTESIO, che si prolunga quasi all'infinito. La misura è uno dei tanti punti variabili che, insieme, definiscono la forma di questo tavolo, sempre sostenuta dalle forti gambe lignee che offrono la sensazione di una sezione poligonale in torsione: il tramite verso un mondo diverso su cui appoggiare gli oggetti del quotidiano. Un tavolo di design che vive con la medesima disinvoltura in ambienti kitchen o living, anche dal gusto più tradizionale.**

The coordinates of space change as CARTESIO top extends, which is almost prolonged endlessly. Measurement is one of the many variable points that together define the shape of this table, always supported by strong wooden legs that offer the feeling of a polygonal section in torsion: the gateway to a different world on which to place daily objects. A design table that lives with the same ease in the kitchen or living room, even with a more traditional taste.



## CARTESIO T88

Tavolo Cartesio T88, frassino Royal Oak RV.RO.38, piano Ceramic Fokos Nero opaco, con opzione del meccanismo antracite senza carter in legno.

Sedia Giorgia S156, frassino Royal Oak RV.RO.38, tessuto Queens grephite.

Cartesio table T88, royal oak RV.RO.38 ash wood, matt black Fokos Ceramic top, anthracite frame without wooden carter (optional).

Giorgia chair S156, royal oak RV.RO.38 ash wood, graphite Queens fabric.







### CARTESIO T88

Tavolo Cartesio T88, frassino bruciato RV.B.71, piano Ceramic Sahara Noir bocciardato, con opzione del meccanismo antracite senza carter in legno.

Sedia Sveva S166, frassino bruciato RV.B.71, tessuto Victoria caramel.

Cartesio table T88, burnt ash wood RV.B.71, bush-hammered Sahara Noir Ceramic top, anthracite frame without wooden carter (optional). Sveva chair S166, burnt ash wood RV.B.71, caramel Victoria fabric.







### **CARTESIO T88**

**Tavolo Cartesio T88, frassino laccato bianco, piano Ceramic Marmo Statuario opaco.  
Sedia Giorgia S156, frassino laccato bianco, tessuto econabuk kiwi.  
Cartesio table T88, white lacquered ash wood, matt Statuario Ceramic top.  
Giorgia chair S156, white lacquered ash wood, kiwi econabuk.**





### CARTESIO T88

Tavolo Cartesio T88, frassino Bruciato RV.B.71, piano Ceramic Invisible White opaco.  
Sedia Diana S103, tessuto Queens Taupe.  
Cartesio table T88, burnt ash wood RV.B.71, matt Invisible White Ceramic top.  
Diana chair S103, taupe Queens fabric.

### CARTESIO T88

Superallungabile telescopico / Super extendable telescopic

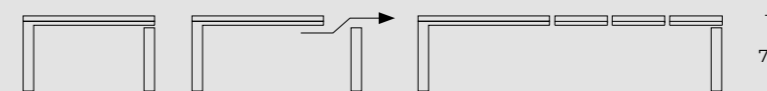

Il meccanismo si allunga consentendo l'inserimento manuale e progressivo di allunghe ad incastro. Le allunghe sono alloggiare in un apposito scomparto interno.  
Piano rettangolare in vetro sp.8 mm, ceramic sp.11 mm, impiallacciato sp.20mm, melaminico sp.19mm

The telescopic frame allows manual and progressive insertion of extensions. The extensions are fitted inside the table.

Rectangular top in glass thk 8 mm, Ceramic thk 11 mm, veneered thk 20 mm or melamine thk 19 mm.

#### PLUS

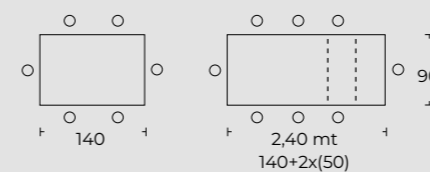

#### SUPER

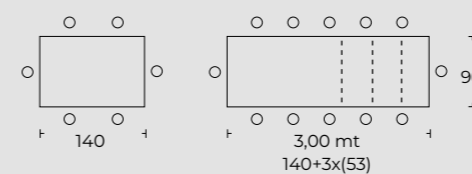

#### DOUBLE

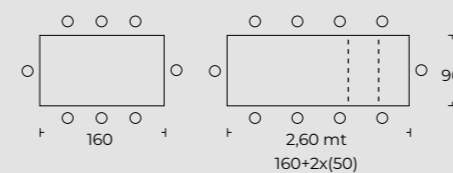

#### ULTRA

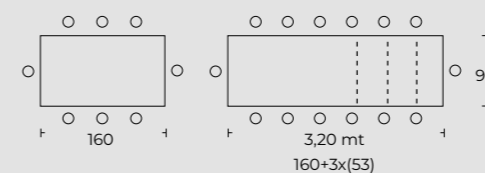

#### TOP

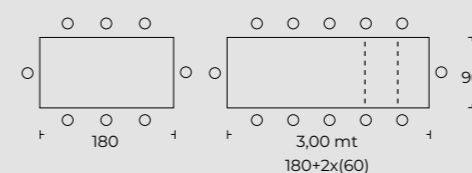

Per le finiture di gambe e piani vedere il campionario My Sample e indicazioni del Listino in vigore.

For the finishings of legs and tops see My Samples collection and indications of price list in effect at the time.





## MATRIX

Design Giuseppe Farinola

L'angolazione cambia tutto, ma resta la percezione d'impeccabile solidità. Le linee scolpite delle gambe in legno e delle estremità di MATRIX appaiono differenti e nuove ogni volta. Lasciando che i materiali del tavolo interagiscano con la luce ed i riflessi, le rimandano all'occhio ora più esili ora più importanti, mantenendo sempre la sensazione di sostegno elegante ad un piano solido ed affidabile anche nelle sua massima estensione. Un tavolo d'ispirazione tradizionale, che si integra in maniera impeccabile nel living come in cucina.

The angle changes everything, but the perception of impeccable solidity remains. The sculpted lines of the wooden legs and ends of MATRIX appear different and new every time. By letting the materials of the table interact with light and reflections, they refer them to the eye more slender at times and more important at other times, always maintaining the sensation of elegant support to a solid top and reliable even in its maximum extension. A traditionally inspired table that integrates flawlessly in the living room as well as in the kitchen.



## MATRIX T78

Tavolo Matrix T78, frassino laccato bianco, piano Ceramic Invisible White opaco.  
Sedia Vanity S376, rigenerato di cuoio cognac.  
Matrix table T78, white lacquered ash wood, matt Invisible White ceramic top.  
Vanity chair S376, cognac regenerated leather.







### **MATRIX T78**

**Tavolo Matrix T78, frassino Royal Oak RV.RO.38, piano Ceramic Calacatta lucido.**

**Sedia Lavinia S158FR, frassino Royal Oak RV.RO.38, ecopelle desert.**

Matrix table T78, Royal Oak RV.RO.38 ash wood, glossy Calacatta Ceramic top.

Lavinia chair S158FR, Royal Oak RV.RO.38 ash wood, desert leatherette.



**MATRIX T78**

Tavolo Matrix T78, frassino Royal Oak RV.RO.38, piano Ceramic Pietra Grey opaco.  
Sedia Alyssa S118, frassino Royal Oak RV.RO.38, ecopelle antracite.  
Matrix table T78, Royal Oak RV.RO.38 ash wood, matt Pietra Grey Ceramic top.  
Alyssa chair S118, Royal Oak RV.RO.38 ash wood, anthracite leatherette.



## MATRIX T78

Tavolo Matrix T78, frassino Royal Oak RV.RO.38, piano Ceramic Fokos Nero opaco.  
Sedia Greta S140FR, frassino Royal Oak RV.RO.38, sedile multistrati laccato nero.  
Matrix table T78, Royal Oak RV.RO.38 ash wood, matt black Fokos Ceramic top.  
Greta chair S140FR, Royal Oak RV.RO.38 ash wood, black lacquered plywood seat.







### MATRIX T78

Tavolo Matrix T78, frassino Sbiancato RV.SB.25, piano Ceramic Fokos Roccia.  
Sedia Giorgia S156, frassino Sbiancato RV.SB.25, lana azzurra.  
Matrix table T78, bleached ash wood RV.SB.25, matt Rock Fokos Ceramic top.  
Giorgia chair S156, bleached ash wood RV.SB.25, light blue wool.





### MATRIX T78

Tavolo Matrix T78, frassino sbiancato RV.SB.25, piano Ceramic Fokos Roccia opaco.  
Sedia Giorgia S156, frassino sbiancato RV.SB.25, lana azzurra.  
Matrix table T78, bleached ash wood RV.SB.25, matt Rock Fokos Ceramic top.  
Giorgia chair S156, bleached ash wood RV.SB.25, light blue wool.

### MATRIX T78

Superallungabile telescopico / Super extendable telescopic

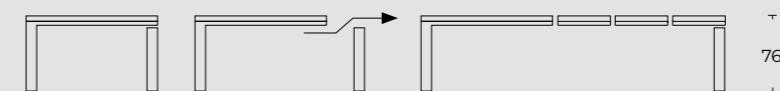

Il meccanismo si allunga consentendo l'inserimento manuale e progressivo di allunghe ad incastro. Le allunghe sono alloggiati in un apposito scomparto interno.  
Piano rettangolare in vetro sp.8 mm, ceramic sp.11 mm, impiallacciato sp.20mm, melaminico sp.19mm

The telescopic frame allows manual and progressive insertion of extensions. The extensions are fitted inside the table.

Rectangular top in glass thk 8 mm, Ceramic thk 11 mm, veneered thk 20 mm or melamine thk 19 mm.

#### PLUS

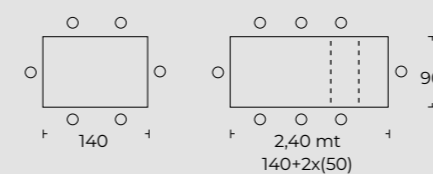

#### SUPER

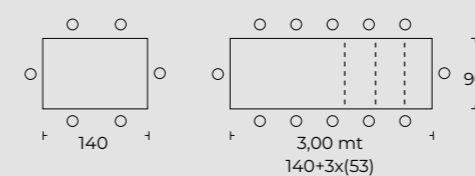

#### DOUBLE

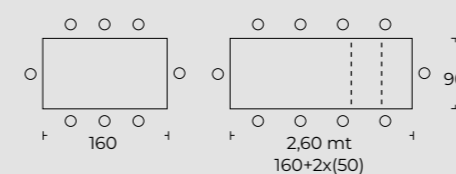

#### ULTRA

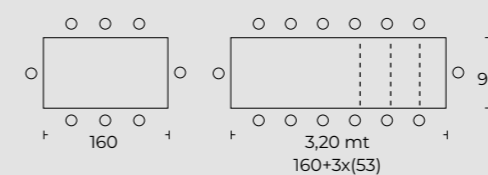

#### TOP

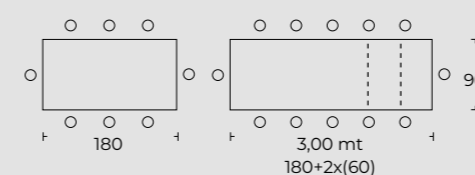

Per le finiture di gambe e piani vedere il campionario My Sample e indicazioni del Listino in vigore.

For the finishings of legs and tops see My Samples collection and indications of price list in effect at the time.





## MADISON

Design Farinola & Dalmasson

Cercando l'interpretazione contemporanea del massimo della classicità, ecco che MADISON è proprio il tavolo come si disegna. Il dettaglio delle gambe piatte e larghe, che vanno a tracciare un segno di consistenza, sono quel solido guizzo anticonformista che le fa diventare importanti e al contempo leggere a un rapido cambio di prospettiva. MADISON lascia che sia il gioco di materiali e colori a rivelare che il piano, appoggiato al meccanismo di allungamento mono- o a doppio stadio, resta impercettibilmente staccato.

Looking for the contemporary interpretation of the ultimate in classicism, MADISON is just as designed. The detail of the flat and wide legs, which mark a sign of consistency, is that solid unconventional twist that makes them become important and light at the same time with a quick change of perspective. MADISON lets the play of materials and colors reveal that the top, placed on the single or two-stage extension mechanism, remains imperceptibly detached.



## MADISON T97

Tavolo Madison T97, frassino noce canaletto RV.NC22, piano vetro velvet opaco extrabianco A.V.XW.  
Sedia Gran Manon S141FR, frassino RV.NC22, rigenerato di cuoio bianco.  
Madison table T97, canaletto walnut RV.NC22 ash wood, matt extrawhite glass top A.V.XW.  
Gran Manon chair S141FR, canaletto walnut RV.NC22 ash wood, white regenerated leather.







### MADISON T97

Tavolo Madison T97, frassino Bruciato RV.B.71, piano Ceramic Marmo Statuario opaco.  
Sedia Cleo S154FR e poltrona Demetra S155FR, frassino Bruciato RV.B.71, lana grigio chiaro.  
Madison table T97, burnt ash wood RV.B.71, matt Statuario ceramic top.  
Cleo chair S154FR and Demetra armchair S155FR, burnt ash wood RV.B.71, light grey wool.





### MADISON T97

Tavolo Madison T97, frassino laccato bianco, piano Noce americano N.26.  
Sedia Greta S140FR, frassino laccato bianco, multistrati laccato bianco.  
Madison table T97. white open pore lacquered ashwood, American walnut top N.26.  
Greta chair S140FR. lacquered white ash wood, lacquered white plywood.





### MADISON T97

Tavolo Madison T97, frassino laccato bianco, piano vetro velvet opaco extrabianco A.V.XW.  
 Sedia Diana S103, tessuto Queens taupe.  
 Madison table T97. white lacquered ash wood. matt extrawhite glass top A.V.XW.  
 Diana chair S103. taupe Queens fabric.

### MADISON T97

Superallungabile telescopico / Super extendable telescopic

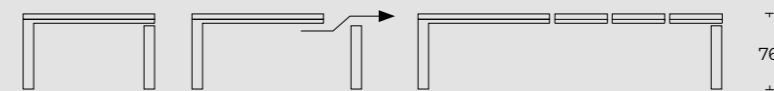

Il meccanismo si allunga consentendo l'inserimento manuale e progressivo di allunghe ad incastro. Le allunghe sono alloggiare in un apposito scomparto interno.  
 Piano rettangolare in vetro sp.8 mm, ceramic sp.11 mm, impiallacciato sp.20mm, melaminico sp.19mm

The telescopic frame allows manual and progressive insertion of extensions. The extensions are fitted inside the table.

Rectangular top in glass thk 8 mm, Ceramic thk 11 mm, veneered thk 20 mm or melamine thk 19 mm.

#### PLUS

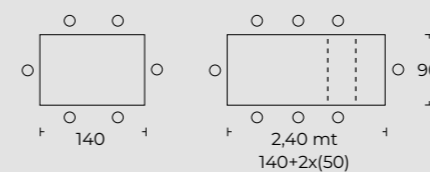

#### SUPER

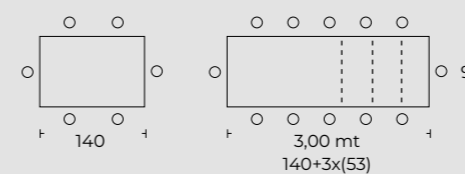

#### DOUBLE

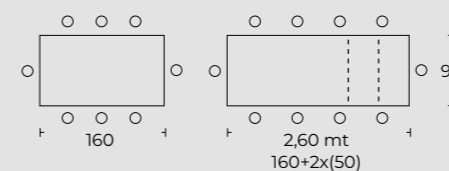

#### ULTRA

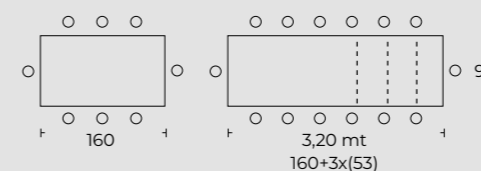

#### TOP

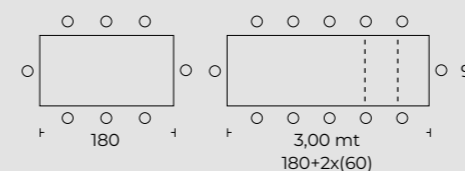

Per le finiture di gambe e piani vedere il campionario My Sample e indicazioni del Listino in vigore.

For the finishings of legs and tops see My Samples collection and indications of price list in effect at the time.





## DIAMOND

Design Farinola & Dalmasson

A guardarlo da vicino, il piano del tavolo DIAMOND sembra librarsi leggermente al di sopra di una base molto classica. Ma la visione d'insieme di questo tavolo scopre gambe importanti dal sapore antico: il riflesso cambia, diventando pura luce nelle laccature o sfumatura velata nelle lavorazioni opache, mentre rivela l'ispirazione storica che si rifà alle sfaccettature di palazzi d'altri tempi, per un tavolo allungabile elegante ed assolutamente contemporaneo.

Looking at it closely, the DIAMOND table top appears to hover slightly above a very classic base. But the overall view of this table reveals important legs with an ancient flavor: the reflection changes, becoming pure light in the lacquering or veiled nuances in the matte production, while revealing the historical inspiration that harks back to the facets of buildings of yesteryear, for an elegant and absolutely contemporary extendable table.



## DIAMOND T96

Tavolo Diamond T96, faggio laccato nero opaco, piano Ceramic Noir Desir lucido.  
Poltrona Demetra S155FR, frassino laccato nero, tessuto Victoria terracotta.  
Diamond table T96, matt black lacquered beech wood, glossy Noir Desir Ceramic top.  
Demetra armchair S155FR, matt black lacquered ash wood, terracotta Victoria fabric.





## DIAMOND T96

Tavolo Diamond T96, piano Ceramic Sahara Noir bocciardato.  
Poltrona Demetra S155FR, tessuto Victoria terracotta.  
Diamond table T96, bush-hammered Sahara Noir Ceramic top.  
Demetra armchair S155FR, terracotta Victoria fabric.

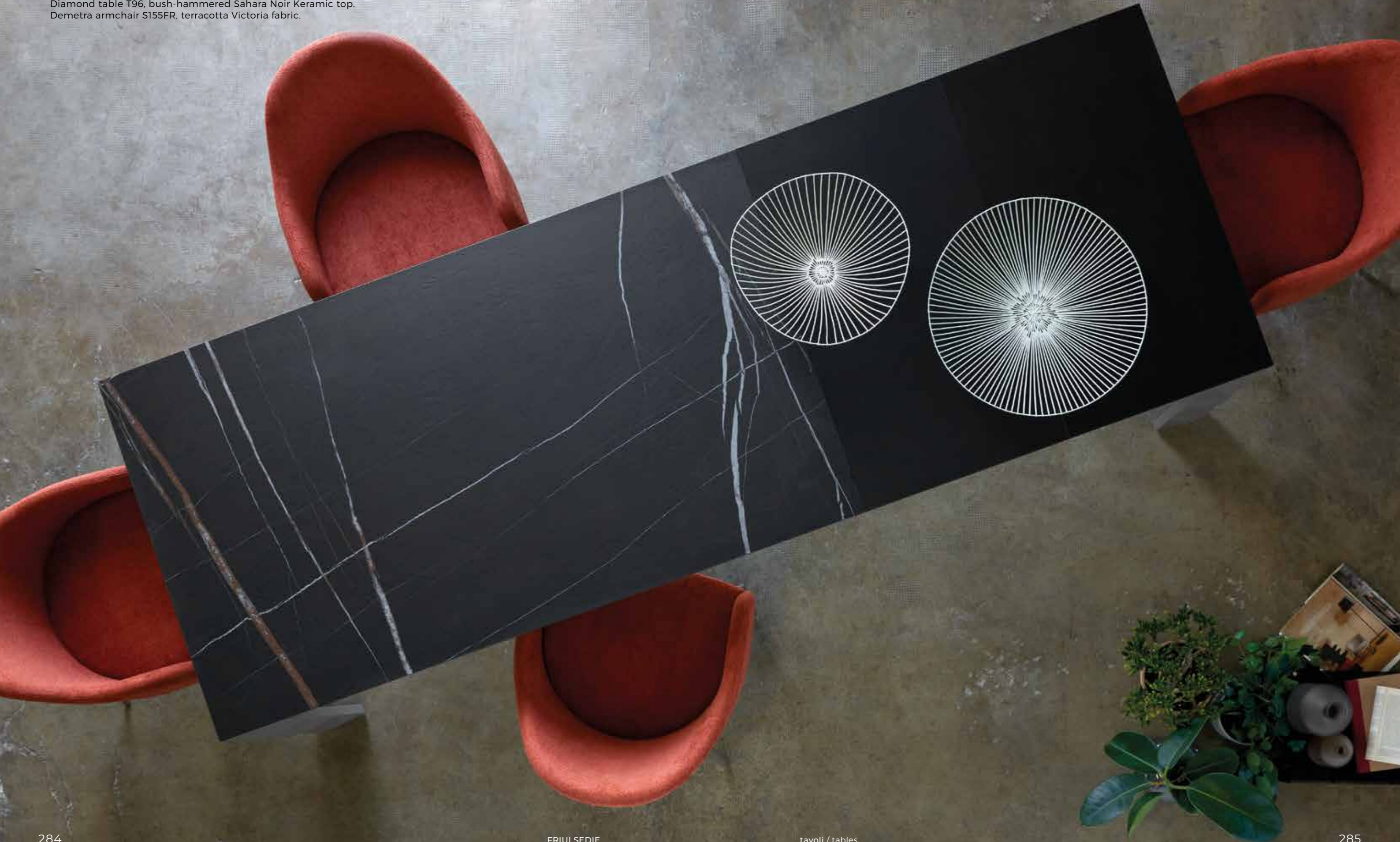





## DIAMOND T96

Tavolo Diamond T96, faggio laccato bianco opaco, piano Ceramic Marmo Statuario opaco.  
Sedia Noah S116MC, metallo oro antico, tessuto Queens graphite.

Diamond table T96, matt white lacquered beech wood, matt Statuary marble Ceramic top.  
Noah chair S116MC, antique golden metal, graphite Queens fabric.



## DIAMOND T96

Tavolo Diamond T96, faggio laccato titanio wood opaco, piano Ceramic Calacatta lucido.  
Poltrona Janis S165MC, metallo titanio, tessuto Victoria elephant.  
Diamond table T96, titanium wood lacquered beech wood, glossy Calacatta Ceramic top.  
Janis armchair S165MC, titanium metal, elephant Victoria fabric.







### DIAMOND T96

Tavolo Diamond T96, faggio laccato titanio wood opaco, piano Ceramic Calacatta lucido.  
 Poltrona Janis S165MC, metallo titanio, tessuto Victoria elephant.  
 Diamond table T96, titanium wood lacquered beech wood, glossy Calacatta Ceramic top.  
 Janis armchair S165MC, titanium metal, elephant Victoria fabric.

### DIAMOND T96

Superallungabile telescopico / Super extendable telescopic

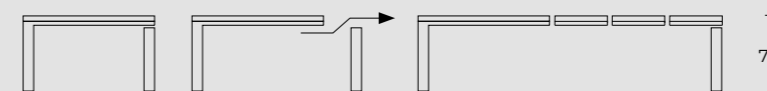

Il meccanismo si allunga consentendo l'inserimento manuale e progressivo di allunghe ad incastro. Le allunghe sono alloggiare in un apposito scomparto interno.  
 Piano rettangolare in vetro sp.8 mm, ceramic sp.11 mm, impiallacciato sp.20mm, melaminico sp.19mm

The telescopic frame allows manual and progressive insertion of extensions. The extensions are fitted inside the table.

Rectangular top in glass thk 8 mm, Ceramic thk 11 mm, veneered thk 20 mm or melamine thk 19 mm.

#### PLUS

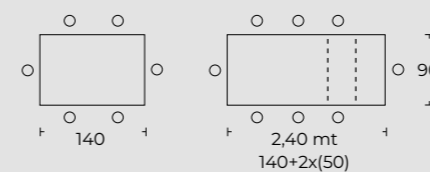

#### SUPER

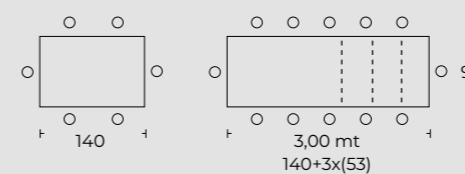

#### DOUBLE

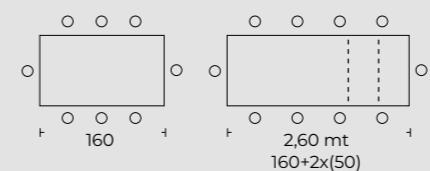

#### ULTRA

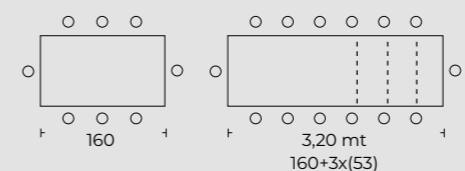

#### TOP

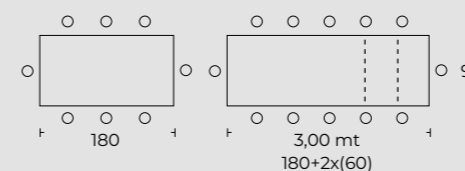

Per le finiture di gambe e piani vedere il campionario My Sample e indicazioni del Listino in vigore.

For the finishings of legs and tops see My Samples collection and indications of price list in effect at the time.





## VICTOR

Design Farinola & Dalmasson

Un vezzo d'ispirazione quasi neoclassica, che si esprime al meglio in ambienti tradizionali che non vogliono privarsi del tocco di un design comunque sempre personale. VICTOR è l'evidenza che c'è ancora molto da esplorare in quello spazio dove si armonizzano la progettualità contemporanea e il desiderio di guardare a forme più morbide. Le linee di VICTOR lo vedono governare ogni ambiente con un'eleganza senza tempo.

A quirk of almost neoclassical inspiration, which is best expressed in traditional environments that do not want to be deprived of the touch of a design that is always personal. VICTOR is the evidence that there is still a lot to explore in the space where contemporary planning and the desire to look at softer forms are harmonized. VICTOR's lines see it governing every environment with a timeless elegance.



**VICTOR T86**

Tavolo Victor T86, faggio laccato bianco opaco, piano Ceramic Arabescato lucido.  
Poltrona Demetra S155MC e sedia Cleo S154MC, metallo ottone, tessuto Victoria lizard green.  
Victor table T86, matt white lacquered beech wood, glossy Arabesque Ceramic top.  
Demetra armchair S155MC and Cleo chair S154MC, brass metal, lizard green Victoria fabric.







## VICTOR T86

Tavolo Victor T86, frassino Royal Oak RV.RO.38, piano impiallacciato, con opzione del meccanismo antracite senza carter in legno. Poltrona Olympia S117MC e sedia Noah S116MC, metallo antracite, tessuto Queens graphite.

Victor table T86, Royal Oak RV.RO.38 ash wood, veneered top, anthracite frame without wooden carter (optional). Olympia armchair S117MC and Noah chair S116MC, anthracite metal, graphite Queens fabric.





**VICTOR T86**

Tavolo Victor T86, frassino Royal Oak RV.RO.38, piano Ceramic Noir Desir lucido, con opzione del meccanismo antracite senza carter in legno. Sedia Noah S116FR, frassino Royal Oak RV.RO.38, tessuto Queens graphite.

Victor table T86, Royal Oak RV.RO.38 ash wood, glossy Noir Desir Ceramic top, anthracite frame without wooden carter (optional). Noah chair S116FR, Royal Oak RV.RO.38 ash wood, graphite Queens fabric.





## VICTOR T86

Tavolo Victor T86, frassino Bruciato RV.B.71, piano Ceramic Calacatta lucido.  
Sedia Cleo S154FR, frassino Bruciato RV.B.71, velluto Teja.  
Victor table T86, burnt ash wood RV.B.71, glossy Calacatta Ceramic top.  
Cleo chair S154FR, burnt ash wood RV.B.71, Teja velvet.







### VICTOR T86

Tavolo Victor T86, frassino Bruciato RV.B.71, piano Ceramic Marmo Statuario opaco.  
Victor table T86, burnt ash wood RV.B.71, matt Statuario Ceramic top.

### VICTOR T86

Superallungabile telescopico / Super extendable telescopic

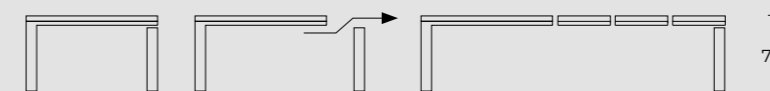

Il meccanismo si allunga consentendo l'inserimento manuale e progressivo di allunghe ad incastro. Le allunghe sono alloggiare in un apposito scomparto interno.

Piano rettangolare in vetro sp.8 mm, ceramic sp.11 mm, impiallacciato sp.20mm, melaminico sp.19mm

The telescopic frame allows manual and progressive insertion of extensions. The extensions are fitted inside the table.

Rectangular top in glass thk 8 mm, Ceramic thk 11 mm, veneered thk 20 mm or melamine thk 19 mm.

#### PLUS

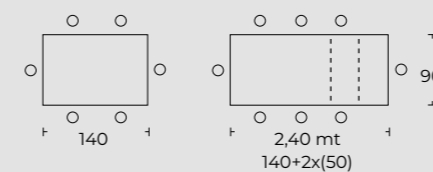

#### SUPER

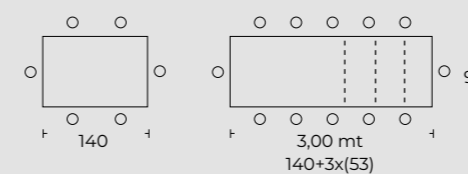

#### DOUBLE

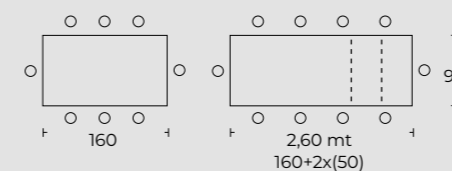

#### ULTRA

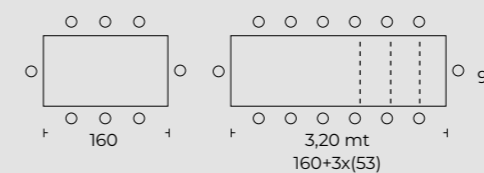

#### TOP

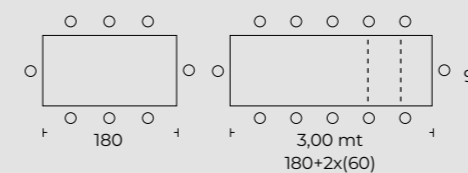

Per le finiture di gambe e piani vedere il campionario My Sample e indicazioni del Listino in vigore.

For the finishings of legs and tops see My Samples collection and indications of price list in effect at the time.



# Spazi completi con class.

SPAZI COMPLETI CON CLASS. LA COLLEZIONE CLASS FRIULSEDIE SEGNA IL LUOGO DELLA CONTINUITÀ. AL CENTRO C'È IL SIGNIFICATO BASE DEL TAVOLO, CHE È SEMPRE UN MOMENTO OLTRE CHE UN OGGETTO: AZIONE, RITROVO E CONDIVISIONE TROVANO ESPRESSIONE IN QUESTO ELEMENTO, QUALUNQUE SIA LA SUA COLLOCAZIONE. I TAVOLI CLASS POSSONO CREARE LO STACCO NECESSARIO OPPURE ESSERE L'ELEMENTO DI FUSIONE DEGLI AMBIENTI. CONCEPITI INIZIALMENTE PER UNA COLLOCAZIONE PIÙ TRADIZIONALE, RAPPRESENTANO QUEL DESIGN BASE DI FRIULSEDIE CHE, NELLA SUA LINEARITÀ, GIÀ INTRODUCE L'AMPIA GAMMA DI POSSIBILITÀ DI PERSONALIZZAZIONE E APRE LA POSSIBILITÀ DI SPOSTARSI DALLA CUCINA ALL'AMBIENTE LIVING, MAGARI OPTANDO PER MATERIALI DAL LOOK SOFISTICATO, COME I PIANI IN VETRO-CERAMICA. LE CONFIGURAZIONI POSSIBILI IN QUESTA COLLEZIONE SONO OLTRE TREMILA TRA MATERIALI E FINITURE, IMPLEMENTATE DAL CUORE TECNOLOGICO DEI TAVOLI FRIULSEDIE, QUEI SISTEMI TELESCOPICI DI ESTENSIONE CHE POSSONO PORTARE I PIANI ALLUNGABILI SINO A OLTRE TRE METRI. TUTTA LA COLLEZIONE CLASS RACCONTA IL PERCORSO CHE DALL'ORIGINE DI FRIULSEDIE HA RAGGIUNTO APICI DI PERSONALIZZAZIONE PARTENDO DA UN'IDEA: LA COMPLESSITÀ SI RAGGIUNGE UN PASSO ALLA VOLTA.

COMPLETE SPACES WITH CLASS. THE FRIULSEDIE CLASS COLLECTION MARKS THE PLACE OF CONTINUITY. AT THE CENTER IS THE BASIC MEANING OF TABLE, WHICH IS ALWAYS A MOMENT OTHER THAN AN OBJECT: ACTION, MEETING AND SHARING FIND EXPRESSION IN THIS ELEMENT, WHATEVER ITS LOCATION. CLASS TABLES CAN CREATE THE NECESSARY DETACHMENT OR BE THE MERGING ELEMENT OF THE ENVIRONMENTS. INITIALLY CONCEIVED FOR A MORE TRADITIONAL LOCATION, THEY REPRESENT THE BASIC DESIGN OF FRIULSEDIE WHICH, IN ITS LINEARITY, ALREADY INTRODUCES THE WIDE RANGE OF POSSIBILITIES OF CUSTOMIZATION AND OPENS UP THE POSSIBILITY OF MOVING FROM THE KITCHEN TO THE LIVING ROOM, PERHAPS BY OPTING FOR MATERIALS WITH A SOPHISTICATED LOOK, SUCH AS GLASS-CERAMIC TOPS. THE POSSIBLE CONFIGURATIONS IN THIS COLLECTION ARE OVER THREE THOUSAND BETWEEN MATERIALS AND FINISHES, IMPLEMENTED BY THE TECHNOLOGICAL HEART OF FRIULSEDIE TABLES, THOSE TELESCOPIC EXTENSION SYSTEMS THAT CAN BRING EXTENDABLE TOPS UP TO OVER THREE METERS. THE WHOLE CLASS COLLECTION DESCRIBES THE PATH THAT FROM THE ORIGINS OF FRIULSEDIE HAS REACHED THE HEIGHTS OF CUSTOMIZATION STARTING FROM AN IDEA: COMPLEXITY IS ACHIEVED ONE STEP AT A TIME.

# CLASS

COLLEZIONE





## GALILEO

Design R & D Friulsedie

**Una solidità immediata già nelle gambe del tavolo GALILEO, che sono quasi bidimensionali e hanno una direzione precisa che parte da un centro ideale, forse il cuore del meccanismo di apertura, e sfrecciano in diagonale agli angoli del tavolo, così veloci che il piano sembra non riuscire a toccarle e finisce col librarsi al di sopra. Nella sua semplicità, GALILEO è un tavolo geniale concepito per il living, ma che grazie a configurazioni, materiali e meccanismi diventa il nucleo perfetto attorno a cui far orbitare ogni ambiente.**

As an immediate solidity as in the legs of the GALILEO table, which are almost two-dimensional and have a precise direction that starts from an ideal center, perhaps the heart of the opening mechanism, and whiz diagonally at the corners of the table, so fast that the top seems not to be able to touch them and ends up soaring above. In its simplicity, GALILEO is an ingenious table conceived for the living room, but thanks to configurations, materials and mechanisms it becomes the perfect core around which to make any environment orbit.



## GALILEO T93

Tavolo Galileo T93, metallo oro antico, piano Ceramic Sahara Noir bocciardato.  
Sedia Sasha S150MT, metallo oro antico, tessuto Queens graphite.  
Galileo table T93, antique gold metal, bush-hammered Sahara Noir Ceramic top.  
Sasha chair S150MT, antique gold metal, graphite Queens fabric.





**GALILEO T93**

Tavolo Galileo T93, metallo bianco, piano Ceramic Arabescato lucido.  
Sedia Mia S151MX, metallo antracite, ecopelle antracite.  
Galileo table T93, white metal, glossy Arabesque Ceramic top.  
Mia chair S151MX, anthracite metal, anthracite leatherette.





### **GALILEO T93**

**Tavolo Galileo T93, metallo ottone, piano vetro velvet opaco nero A.V.N.  
Sedia Mia S151MT, metallo ottone, tessuto Victoria caramel.**  
Galileo table T93, brass metal, matt black A.V.N. glass top.  
Mia chair S151MT, brass metal, caramel Victoria fabric.



## GALILEO T93

Tavolo Galileo T93, metallo antracite, piano Ceramic Noir Desir lucido.  
Sedia Brenda S102, tessuto Queens taupe.  
Galileo table T93, anthracite metal, glossy Noir Desir Ceramic top.  
Brenda chair S102, taupe Queens fabric.







### GALILEO T93

Tavolo Galileo T93, metallo antracite, piano Ceramic Noir Desir lucido.  
 Sedia Margie S104V, metallo antracite, tessuto Queens brown.  
 Galileo table T93, anthracite metal, glossy Noir Desir Ceramic top.  
 Margie chair S104V, anthracite metal, brown Queens fabric.



### GALILEO T93

Tavolo Galileo T93, metallo antracite, piano Ceramic Noir Desir lucido.  
 Sedia Diana S103, tessuto Queens graphite.  
 Galileo table T93, anthracite metal, glossy Noir Desir Ceramic top.  
 Diana chair S103, graphite Queens fabric.





### **GALILEO T93**

**Tavolo Galileo T93, metallo bianco, piano vetro velvet opaco extrabianco A.V.XW.  
Sedia Jo S397op, polipropilene opaco blu.**  
Galileo table T93, white metal, matt extrawhite A.V.XW glass top.  
Jo chair S397op, matt blue polypropylene.





**GALILEO T93**

Tavolo Galileo T93, metallo bianco, piano Ceramic Invisible White opaco.  
Sedia Brenda S102, tessuto Queens Taupe.  
Galileo table T93, white metal, matt Invisible White Ceramic top.  
Brenda chair S102, taupe Queens fabric.





### GALILEO T93

Tavolo Galileo T93, metallo antracite, piano Ceramic Pietra Grey opaco.  
Sedia Margie S104V, metallo antracite, ecopelle antracite.  
Galileo table T93, anthracite metal, matt Pietra Grey Ceramic top.  
Margie chair S104V, anthracite metal, anthracite leatherette.

### GALILEO T93

Superallungabile telescopico / Super extendable telescopic

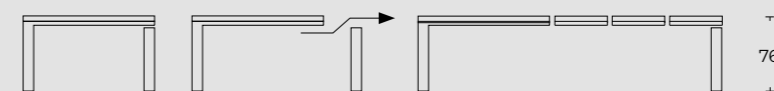

Il meccanismo si allunga consentendo l'inserimento manuale e progressivo di allunghe ad incastro. Le allunghe sono alloggiate in un apposito scomparto interno.

Piano rettangolare in vetro sp.8 mm, ceramic sp.11 mm, impiallacciato sp.20mm, melaminico sp.19mm.

The telescopic frame allows manual and progressive insertion of extensions. The extensions are fitted inside the table.

Rectangular top in glass thk 8 mm, Ceramic thk 11 mm, veneered thk 20 mm or melamine thk 19 mm

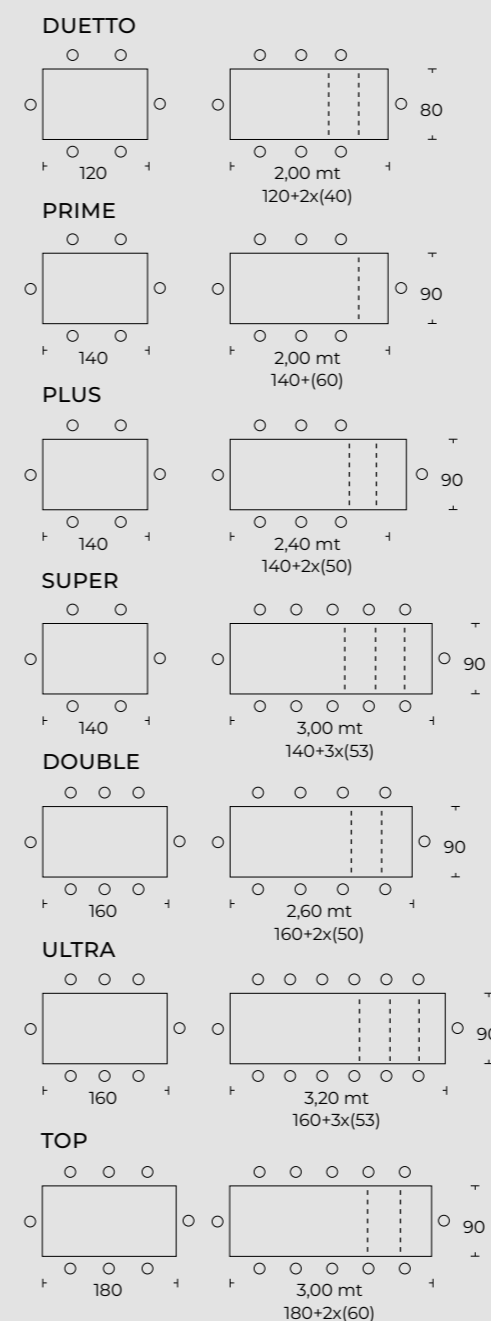

Per le finiture di gambe e piani vedere il campionario My Sample e indicazioni del Listino in vigore.

For the finishings of legs and tops see My Samples collection and indications of price list in effect at the time.





## ZENITH

Design R & D Friulsedie

C'è una linea alta e sottile che collega gli elementi di ZENITH ad ogni punto dell'ambiente in cui si colloca. È l'espressione della leggerezza e dell'essenzialità che vivono in questo tavolo. Le possibilità di espansione rendono ZENITH adatto sia a spazi contenuti come pure ad ambienti più grandi. È un tavolo fresco, giovane. È esemplare del design più puro, sempre estremamente funzionale e atto ad elevare gli elementi di un living.

There is a high and thin line that connects the elements of ZENITH to every point of the environment in which it is located. It is the expression of the lightness and essential that live in this table. The possibility to expand makes ZENITH suitable for small spaces as well as bigger environments. It is a fresh and young table. It is exemplary of the purest design, always extremely functional and designed to elevate the elements of a living room.



## ZENITH T91

Tavolo Zenith T91, metallo antracite, piano impiallacciato Noce americano N.26.  
Sedia City S127, ecopelle antracite.  
Zenith table T91, anthracite metal, American walnut N.26 veneered top.  
City chair S127, anthracite leatherette.







### ZENITH T91

Tavolo Zenith T91, metallo antracite, piano Ceramic Noir Desir lucido.  
Sedia Bally S105, metallo antracite, tessuto Queens brown.  
Galileo table T93, anthracite metal, glossy Noir Desir Ceramic top.  
Bally chair S105, anthracite metal, brown Queens fabric.





### ZENITH T91

Tavolo Zenith T91, metallo bianco, piano melaminico tavolato Royal Oak 988.  
Sedia Micol S110, polipropilene opaco verde oliva.  
Zenith table T91, white metal, Royal Oak 988 melamine top.  
Micol chair S110, matt olive green polypropylene.



## ZENITH T91

Tavolo Zenith T91, metallo bianco, piano impiallacciato Noce Americano N.26.  
Sedia Jo S397op, polipropilene opaco bianco.  
Zenith table T91, white metal, American walnut top N.26.  
Jo chair S397op, matt white polypropylene.







### ZENITH T91

Tavolo Zenith T91, metallo bianco, piano vetro opaco extrabianco A.V.XW.  
Zenith table T91, white metal, matt extrawhite A.V.XW glass top.

### ZENITH T91

Superallungabile telescopico / Super extendable telescopic

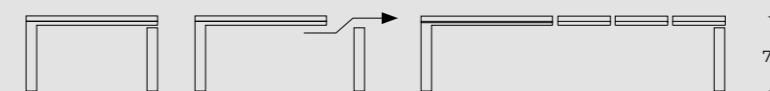

Il meccanismo si allunga consentendo l'inserimento manuale e progressivo di allunghe ad incastro. Le allunghe sono alloggiare in un apposito scomparto interno.

Piano rettangolare in vetro sp.8 mm, ceramic sp.11 mm, impiallacciato sp.20mm, melaminico sp.19mm.

The telescopic frame allows manual and progressive insertion of extensions. The extensions are fitted inside the table.

Rectangular top in glass thk 8 mm, Ceramic thk 11 mm, veneered thk 20 mm or melamine thk 19 mm

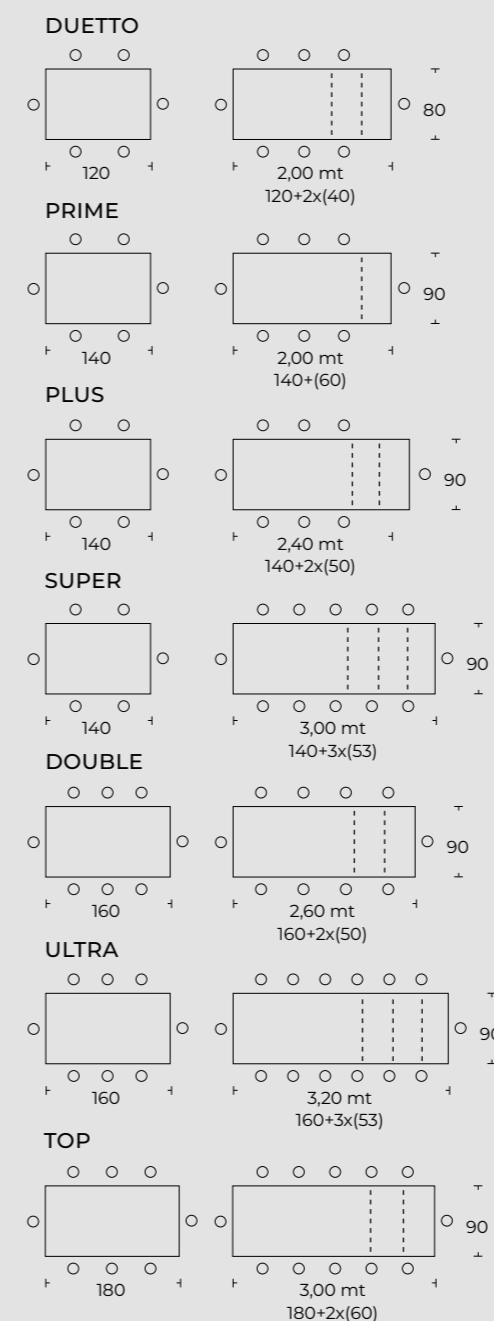

Per le finiture di gambe e piani vedere il campionario My Sample e indicazioni del Listino in vigore.

For the finishings of legs and tops see My Samples collection and indications of price list in effect at the time.





## LEON

Design Farinola & Dalmasson

Ci sono materiali che già da sé trasmettono stati d'animo precisi. Il legno del frame di LEON mantiene la calda pacatezza del tono tradizionale nella voce di questo tavolo, che diventa più estroversa quando si accosta a piani in vetro-ceramica. Trapela l'indole versatile nella sua espandibilità, come pure nelle varianti materiche dei piani, che si esprimono in un linguaggio di sobrietà e praticità anche nella proposta a piano fisso.

There are materials that convey precise moods by themselves. The wood of the LEON frame maintains the warm calmness of the traditional tone in the voice of this table, which becomes more extrovert when approached with glass ceramic tops. The versatile nature transpires in its expandability as well as in the material variants of the tops, which are expressed in a language of sobriety and practicality also in the fixed top proposal.



## LEON T98

Tavolo Leon T98, frassino bruciato RV.B71, piano Ceramic Invisible White opaco, con opzione del meccanismo titanio senza carter in legno.

Sedia Diana S103, tessuto Queens taupe.

Leon table T98, burnt ash RV.B71, matt Invisible White Ceramic top, titanium frame without wooden carter (optional).

Diana chair S103, taupe Queens fabric.







### LEON T98

Tavolo Leon T98, frassino tabacco RV.T24, piano Ceramic Fokos Sale opaco.  
Sedia Brenda S102, tessuto Queens Petrol.  
Leon table T98, tobacco RV.T24 ash wood, matt Fokos Salt Ceramic top.  
Brenda chair S102, petrol Queens fabric.





**LEON T98**

Tavolo Leon T98, frassino tabacco RV.T24, piano Ceramic Fokos Sale opaco.  
 Sedia Sasha S150FR, frassino tabacco RV.T24, ecopelle fango.  
 Leon table T98, tobacco RV.T24 ash wood, matt Fokos Salt Ceramic top.  
 Sasha chair S150FR, tobacco RV.T24 ash wood, mud leatherette.







### LEON T98

Tavolo Leon T98, frassino Bruciato RV.B71, piano Ceramic Invisible White opaco.  
Sedia Diana S103, tessuto Queens Taupe.  
Leon table T98, burnt ash wood RV.B71, matt Invisible White Ceramic top.  
Diana chair S103, taupe Queens fabric.

### LEON T98

Superallungabile telescopico / Super extendable telescopic

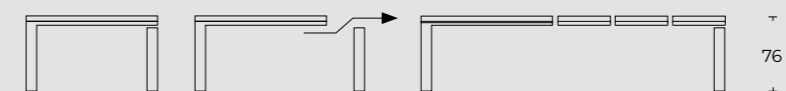

Il meccanismo si allunga consentendo l'inserimento manuale e progressivo di allunghe ad incastro. Le allunghe sono alloggiate in un apposito scomparto interno.

Piano rettangolare in vetro sp.8 mm, ceramic sp.11 mm, impiallacciato sp.20mm, melaminico sp.19mm.

The telescopic frame allows manual and progressive insertion of extensions. The extensions are fitted inside the table.

Rectangular top in glass thk 8 mm, Ceramic thk 11 mm, veneered thk 20 mm or melamine thk 19 mm

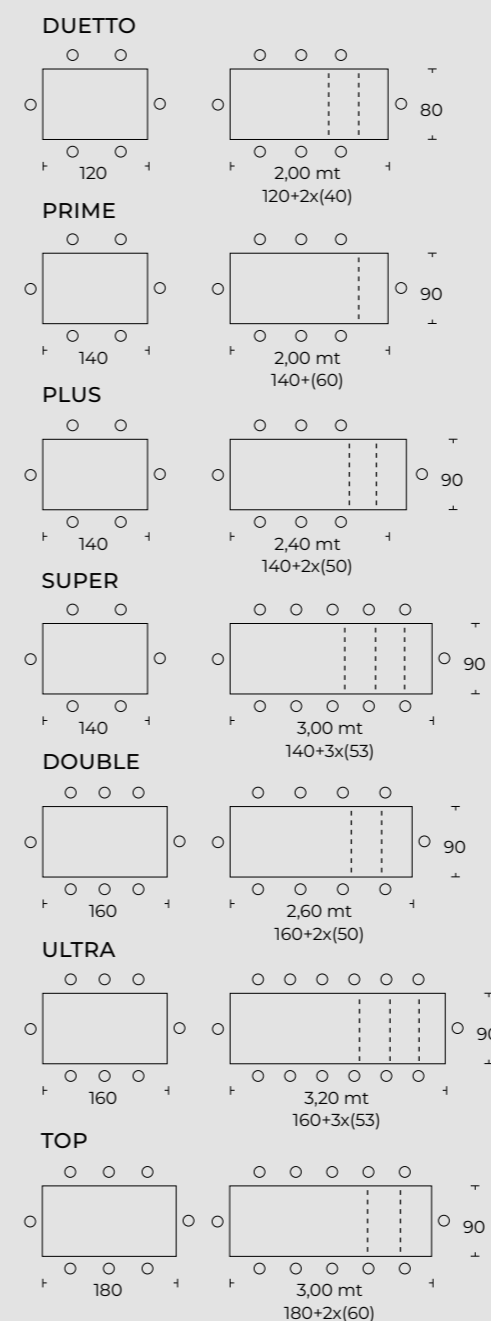

Per le finiture di gambe e piani vedere il campionario My Sample e indicazioni del Listino in vigore.

For the finishings of legs and tops see My Samples collection and indications of price list in effect at the time.



# Allineamenti metropolitani.

ALLINEAMENTI METROPOLITANI È UNA PICCOLA GALASSIA, QUESTA COLLEZIONE FRIULSEDIE PLANET, CHE RACCHIUDE IL MEDESIMO CONCEPT DEI TAVOLI PIÙ GRANDI ENTRO I TRATTI PIÙ MISURATI DI PIANI CHE RISPETTANO SOPRATTUTTO GLI SPAZI OTTIMIZZATI DEI LIVING CONTEMPORANEI. IL DESIGN INCONFONDIBILE DELLE BASI DI QUESTI TAVOLI SPICCA ANCHE IN AMBIENTI DALLE DIMENSIONI PIÙ CONTENUTE, ENFATIZZANDONE LE SCELTE DI STILE E RIAFFERMANDO LA FUNZIONALITÀ DI CENTRO DEL VIVERE CHE IL TAVOLO HA SEMPRE E COMUNQUE. ATTORNO A QUESTI MODELLI ORBITANO COMESATELLITI PERSONE E USI, CHE CAMBIANO E SI ALTERNANO QUASI A SEGUIRE LE ERE DEL VISSUTO QUOTIDIANO. LA POSSIBILITÀ DI ALLUNGARE I PIANI DI ALCUNI DI QUESTI TAVOLI È PARI ALLA CAPACITÀ DI RIVOLUZIONE DI UN PIANETA, CHE COSÌ MOSTRA CON NATURALEZZA TUTTE LE SUE FACCE ALLA LUCE DI UN SOLE, PROPRIO COME LE ESTENSIONI DISPIEGANO TUTTA LA LORO CAPACITÀ DI ACCOGLIENZA.

METROPOLITAN ALIGNMENTS THIS FRIULSEDIE PLANET COLLECTION IS A SMALL GALAXY, WHICH EMBODIES THE SAME CONCEPT AS THE LARGER TABLES WITHIN THE MORE MEASURED SECTIONS OF TOPS THAT, ABOVE ALL, RESPECT THE OPTIMIZED SPACES OF CONTEMPORARY LIVING ROOMS. THE UNMISTAKABLE DESIGN OF THE BASES OF THESE TABLES ALSO STANDS OUT IN ENVIRONMENTS WITH SMALLER DIMENSIONS, EMPHASIZING THE STYLE CHOICES AND REAFFIRMING THE FUNCTIONALITY OF CENTER OF LIFE THAT THE TABLE ALWAYS HAS. PEOPLE AND USES REVOLVE - LIKE SATELLITES - AROUND THESE MODELS, CHANGING AND ALTERNATING AS IF TO FOLLOW THE ERAS OF EVERYDAY LIFE. THE POSSIBILITY OF EXTENDING THE TOPS OF SOME OF THESE TABLES IS EQUAL TO THE REVOLUTION CAPACITY OF A PLANET, WHICH THUS NATURALLY SHOWS ALL ITS FACES IN THE LIGHT OF A SUN, JUST LIKE THE EXTENSIONS UNFOLD THEIR FULL RECEPTION CAPACITY.

# PLANET

COLLEZIONE





## SATURNO

Design Giuseppe Farinola

Forme tonde o sagomate che si espandono nel piano, come per far posto ai satelliti che mano a mano si avvicinano al nucleo personale. SATURNO è proprio così: rielabora il concetto di spazio nella sfera domestica anche quando le opzioni di ambiente sono più misurate. È come un centro di attrazione consistente dalle dimensioni inizialmente contenute, che può trasformarsi, con pochi gesti, in un nuovo universo a sé stante.

Round or molded shapes that expand in the top, as if to make room for the satellites that gradually come closer to the personal core. SATURNO is just like that: it re-elaborates the concept of space in the domestic sphere even when the environment options are more contained. It is like an initially small-sized consolidated center of attraction, which can transform, with a few gestures, into a new separate universe.



## SATURNO T31

Tavolo Saturno T31, allungabile syncro, metallo ottone, piano Ø 130 vetro velvet opaco tortora A.V.T.  
Poltrona Janis S165MC, metallo ottone, tessuto Victoria elephant.  
Saturno table T31, syncro extendable, brass metal, Ø 130 matt taupe A.V.T. round glass top.  
Janis armchair S165MC, brass metal, elephant Victoria fabric.







### SATURNO T31

Tavolo Saturno T31, allungabile syncro, metallo titanio, piano sagomato 130x130 vetro velvet opaco extrabianco A.V.XW. Poltrona Janis S165MC, metallo titanio, tessuto Victoria elephant. Saturno table T31, syncro extendable, titanium metal, 130x130 matt extrawhite A.V.XW. shaped glass top. Janis armchair S165MC, titanium metal, elephant Victoria fabric.







### SATURNO T31

Tavolo Saturno T31, allungabile syncro, metallo ottone, piano Ø 130 vetro velvet opaco nero A.V.N.  
Saturno table T31, syncro extendable, brass metal, Ø 130 matt black A.V.N. round glass top.

### SATURNO T31

Allungabile syncro / Extendable syncro

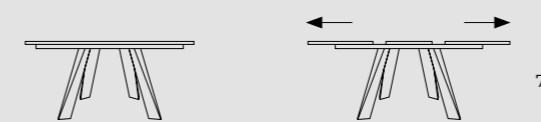

Meccanismo allungabile ad apertura sincronizzata. Allunga a libro integrata nella struttura.  
Synchronized extendable mechanism. Hinged extension integrated into the frame.

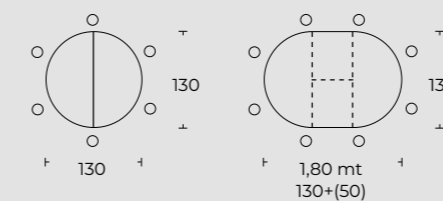

Piano tondo in vetro sp.12 mm  
Round top in glass thk 12 mm

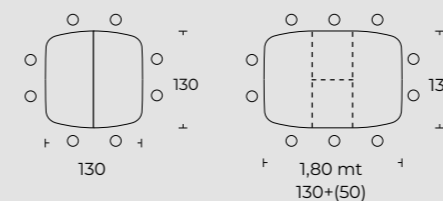

Piano sagomato in vetro sp.12 mm  
Shaped top in glass thk 12 mm

Per le finiture di gambe e piani vedere il campionario My Sample e indicazioni del Listino in vigore.

For the finishings of legs and tops see My Samples collection and indications of price list in effect at the time.





## SIRIUS

Design Farinola & Dalmasson

**È l'unione di circolarità e linearità: le dimensioni geometriche si risolvono nell'impulso delle gambe metalliche a sezione triangolare. Sono linee inclinate verso un centro ideale che sostengono il piano di vetro la cui forma, sagomata o rotonda, può ulteriormente svilupparsi e allungarsi. Questa completezza rende SIRIUS un elemento duttile e dinamico nell'equilibrio dello spazio domestico in cui si colloca, trasformandolo all'occorrenza in un prezioso alleato del vivere contemporaneo.**

It is the union of circularity and linearity: the geometric dimensions are resolved in the impulse of the metal legs with a triangular section. They are inclined lines towards an ideal center that support the glass top whose shape, shaped or round, can further develop and lengthen. This completeness makes SIRIUS a flexible and dynamic element in the equilibrium of the domestic space in which it is located, transforming it into a precious ally of contemporary living if necessary.





### SIRIUS T33

Tavolo Sirius T33, allungabile syncro, metallo bianco, piano Ø 130 vetro velvet opaco bianco A.V.XW.  
 Poltrona Demetra S155MC, metallo oro antico, tessuto Victoria lizard green.  
 Sirius table T33, syncro extendable, white metal, Ø 130 matt extrawhite A.V.XW. round glass top.  
 Demetra armchair S155MC, antique golden metal, lizard green Victoria fabric.







### SIRIUS T33

Tavolo Sirius T33, allungabile syncro, metallo antracite, piano Ø 130 vetro velvet opaco nero A.V.N.  
 Poltrona Olympia S117MC, metallo antracite, tessuto Queens graphite.  
 Sirius table T33, syncro extendable, anthracite metal, Ø 130 matt black A.V.N. round glass top.  
 Olympia armchair S117MC, anthracite metal, graphite Queens fabric.

### SIRIUS T33

Allungabile syncro / Extendable syncro

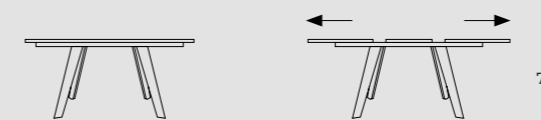

Meccanismo allungabile ad apertura sincronizzata. Allunga a libro integrata nella struttura.  
 Synchronized extendable mechanism. Hinged extension integrated into the frame.

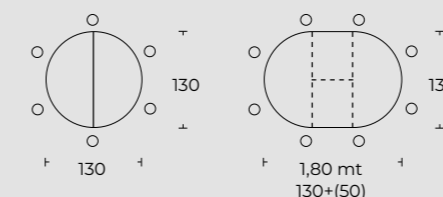

Piano tondo in vetro sp.12 mm  
 Round top in glass thk 12 mm

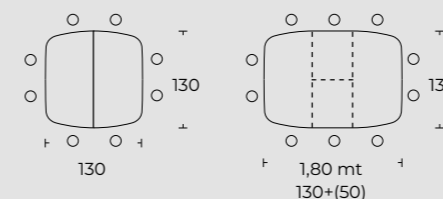

Piano sagomato in vetro sp.12 mm  
 Shaped top in glass thk 12 mm

Per le finiture di gambe e piani vedere il campionario My Sample e indicazioni del Listino in vigore.

For the finishings of legs and tops see My Samples collection and indications of price list in effect at the time.





## APOLLO

Design R & D Friulsedie

**Il piede diventa un atto scultoreo, che sospende il piano con un intreccio polidimensionale ingegnoso. È questa l'affermazione di identità di APOLLO, che anche nelle dimensioni originarie più contenute e nei suoi profili sagomati o tondi promette molto. E mantiene ancora di più. A piano fisso o espandibile, APOLLO è il tavolo che oltrepassa tutte le distinzioni d'ambiente con la sua inconsueta leggerezza.**

The foot becomes a sculptural act, which suspends the top with an ingenious polydimensional weave. This is the affirmation of the identity of APOLLO, which even in the more contained original dimensions and in its shaped or round profiles promises a lot. And it does support even more. With a fixed or expandable top, APOLLO is the table that goes beyond all environmental distinctions with its unusual lightness.



## APOLLO T30

Tavolo Apollo T30, allungabile syncro, metallo antracite, piano Ø 130 vetro velvet opaco extrabianco A.V.XW.  
Sedia Bally S105, metallo antracite, tessuto Queens graphite.  
Apollo table T30, syncro extendable, anthracite metal, Ø 130 matt extrawhite A.V.XW. round glass top.  
Bally chair S105, anthracite metal, graphite Queens fabric.







### APOLLO T30

Tavolo Apollo T30, metallo bicolore, piano Ø 130 vetro velvet opaco nero A.V.N.  
Sedia Cleo S154MC, metallo nero, tessuto Victoria gold.

Apollo table T30, syncro extendable, bicolor metal, Ø 130 matt black A.V.N. round glass top.  
Cleo chair S154MC, black metal, gold Victoria fabric.





### APOLLO T30

Tavolo Apollo T30, allungabile syncro, metallo titanio, piano Ø 130 vetro velvet opaco tortora A.V.T.  
 Sedia Diana S103, tessuto Queens taupe.  
 Saturno table T31, syncro extendable, titanium metal, Ø 130 matt taupe A.V.T. round glass top.  
 Diana chair S103, taupe Queens fabric.

### APOLLO T30

Allungabile syncro / Extendable syncro



Meccanismo allungabile ad apertura sincronizzata. Allunga a libro integrata nella struttura.  
 Synchronized extendable mechanism. Hinged extension integrated into the frame.

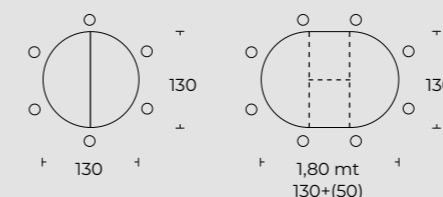

Piano tondo in vetro sp.12 mm  
 Round top in glass thk 12 mm

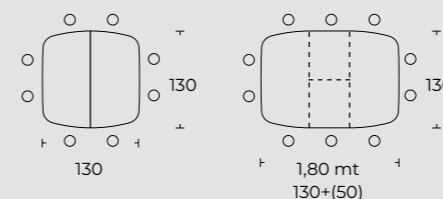

Piano sagomato in vetro sp.12 mm  
 Shaped top in glass thk 12 mm

Per le finiture di gambe e piani vedere il campionario My Sample e indicazioni del Listino in vigore.

For the finishings of legs and tops see My Samples collection and indications of price list in effect at the time.





## RAFFAELLO

Design Farinola & Dalmasson

Un piccolo capolavoro di composizione, un tavolo perfetto nella potenzialità dei suoi piani allungabili in vetro che possono essere tondi o sagomati. Questa linearità si unisce al guizzo che ha trasformato un'idea forse classica - quella della gamba metallica a sezione rettangolare - in un forte movimento verso l'alto, che assume un impeto dinamico quasi futurista. RAFFAELLO è un tavolo che sa prontamente cogliere ed assecondare i molteplici tratti necessari del quotidiano.

A small masterpiece of composition, a perfect table in the potential of its extendable glass tops that can be round or shaped. This linearity joins the flicker that has transformed a perhaps classical idea - that of the metal leg with a rectangular section - into a strong upward movement, which takes on an almost futuristic dynamic impetus. RAFFAELLO is a table that can readily grasp and accommodate the many necessary features of everyday life.





### RAFFAELLO T32

Tavolo Raffaello T32, allungabile syncro, metallo ottone, piano Ø 130 vetro velvet opaco tortora A.V.T.  
 Sedia Vanilla S167, metallo ottone, tessuto Victoria june bug.  
 Raffaello table T32, syncro extendable, brass metal, Ø 130 matt taupe A.V.T. round glass top.  
 Vanilla chair S167, brass metal, june bug Victoria fabric.







### RAFFAELLO T32

Tavolo Raffaello T32, allungabile syncro, metallo nero, piano sagomato 130x130  
 vetro velvet opaco bianco A.V.XW.

Poltrona Janis S165MC, metallo nero, velluto brandy.

Raffaello table T32, syncro extendable, black metal, 130x130 matt extrawhite A.V.XW shaped glass top.  
 Janis armchair S165MC, black metal, brandy velvet.

### RAFFAELLO T32

Allungabile syncro / Extendable syncro

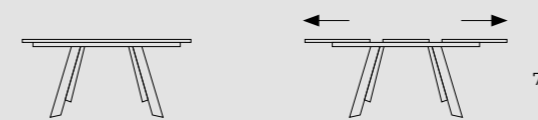

Meccanismo allungabile ad apertura sincronizzata. Allunga a libro integrata nella struttura.  
 Synchronized extendable mechanism. Hinged extension integrated into the frame.

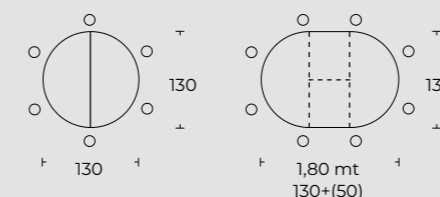

Piano tondo in vetro sp.12 mm  
 Round top in glass thk 12 mm

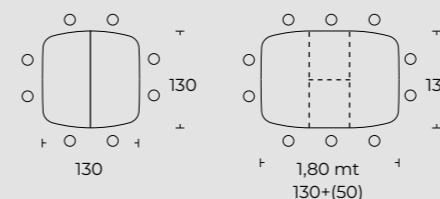

Piano sagomato in vetro sp.12 mm  
 Shaped top in glass thk 12 mm

Per le finiture di gambe e piani vedere il campionario My Sample  
 e indicazioni del Listino in vigore.

For the finishings of legs and tops see My Samples collection  
 and indications of price list in effect at the time.





## GIOTTO

Design R & D Friulsedie

**Una stella fissa, il ritorno al riferimento di base che indica la direzione, quello che disegna l'equilibrio ideale delle proporzioni. GIOTTO ha un concept primario, la sua bellezza si esprime nell'elaborazione della base e così presiede tutte le dimensioni del quotidiano, pur nella sua unicità dimensionale a piano fisso. È un tavolo che descrive il perimetro perfetto attorno al quale far vivere con stile anche gli ambienti più misurati.**

A fixed star, the return to the basic reference that indicates the direction, the one that draws the ideal balance of proportions. GIOTTO has a primary concept, its beauty is expressed in the elaboration of the base and so it presides over all the dimensions of everyday life, despite its fixed-level dimensional uniqueness. It is a table that describes the perfect perimeter around which to bring even the most contained environments elegantly to life.



## GIOTTO T25

Tavolo Giotto T25, metallo oro rosa, piano sagomato 120x120 impiallacciato rovere bruciato RV.B.71.

Poltrona Janis S165MC, metallo oro rosa, velluto brandy.

Giotto table T25, fixed, rose gold metal, 120x120 burnt ash RV.B.71 veneered shaped top.

Janis armchair S165MC, rose gold metal, brandy velvet.







### GIOTTO T25

Tavolo Giotto T25, fisso, metallo multicolor smart, piano sagomato 120x120 vetro velvet opaco extrabianco AV.XW. Sedia Margie S104V, metallo antracite, ecopelle fango.

Giotto table T25, fixed, smart multicolor metal, 120x120 matt extrawhite A.V.XW. glass shaped top. Margie chair S104V, anthracite metal, mud leatherette.





### GIOTTO T25

Tavolo Giotto T25, fisso, per interni, metallo bianco, piano Ø 120 vetro velvet opaco extrabianco AVXW.  
Sedia Nadir S109, polipropilene bianco.

Giotto table T25, fixed, for indoor use, white metal, Ø 120 matt extrawhite A.V.XW. glass top.  
Nadir chair S109, matt white polypropylene.





### GIOTTO T25

Tavolo Giotto T25, fisso, piano sagomato 120x120 impiallacciato noce canaletto RV.NC.22.  
 Sedia Cleo S154MX, metallo antracite, lana tabacco.  
 Giotto table T25, fixed, 120x120 canaletto walnut RV.NC22 veneered shaped top.  
 Cleo chair S154MX, anthracite metal, tobacco wool.

### GIOTTO T25

Fisso / Fixed

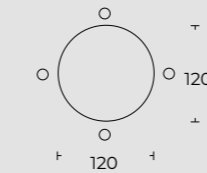
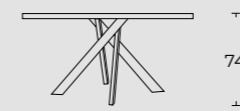

**Piano tondo fisso in vetro sp.10 mm.**  
 Fixed round top in glass thk 10 mm.

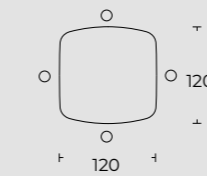
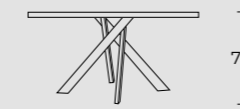

**Piano sagomato fisso in vetro sp.10 mm o impiallacciato frassino spazzolato sp.30 mm.**  
 Fixed shaped top in glass thk 10 mm or brushed veneered ash wood thk 30 mm.

**Per le finiture di gambe e piani vedere il campionario My Sample e indicazioni del Listino in vigore.**

For the finishings of legs and tops see My Samples collection and indications of price list in effect at the time.



Ideare e produrre  
design è  
un costante  
confronto con  
il contemporaneo.

IDEARE E PRODURRE DESIGN È UN COSTANTE  
CONFRONTO CON IL CONTEMPORANEO.  
MATERIALI SEMPRE PIÙ SOFISTICATI SI INSERISCONO  
NEGLI AMBIENTI ABITATIVI ATTRAVERSO GLI  
OGGETTI DELQUOTIDIANO, E ANCHE GLI ARREDI  
DIVENTANO UNA FUNZIONALE SINTESI DI  
RICERCA E INNOVAZIONE. TUTTO QUESTO, IN  
CIASCUNO DEI NOSTRI PROGETTI, SI INCONTRA  
CON IL GUSTO PERSONALE E CON UNA PRASSI  
PRODUTTIVA CHE RISPETTANO I CRITERI DELLE  
TECNOLOGIE PIÙ AVANZATE, CONIUGANDOLE  
AI VALORI TRADIZIONALI E COLLOCANDOSI  
OGNI VOLTA CON LA MASSIMA CURA IN OGNI  
AMBIENTE. CIÒ CHE CONTA PER NOI È CHE  
LA SEDUTA CHE SCEGLIETE VI APPARTENGA  
DAVVERO. CHE RISPECCHI AL 100% L'IDEA CHE  
AVETE A CUORE, L'AMBIENTE CHE VOLETE CREARE  
E ABITARE. PER QUESTO ABBIAMO CONCEPITO  
UNA PROPOSTA DI PERSONALIZZAZIONE ALTISSIMA  
DEI NOSTRI PRODOTTI. VI ACCOMPAGNIAMO  
ATTRAVERSO UN MONDO FATTO DI TESSUTI,  
MATERIALI E STILI PER CREARE LA VOSTRA SEDUTA.

CONCEIVING AND PRODUCING DESIGN IS  
A CONSTANT CONFRONTATION WITH THE  
CONTEMPORARY. MORE AND MORE SOPHISTICATED  
MATERIALS FIT INTO LIVING ENVIRONMENTS  
THROUGH THE OBJECTS OF EVERYDAY LIFE, AND  
EVEN THE FURNISHINGS BECOME A FUNCTIONAL  
SYNTHESIS OF RESEARCH AND INNOVATION.  
ALL OF THIS, IN EACH OF OUR PROJECTS, MEETS  
PERSONAL TASTE AND PRODUCTION PRACTICE  
THAT RESPECT THE CRITERIA OF THE MOST  
ADVANCED TECHNOLOGIES, COMBINING THEM WITH  
TRADITIONAL VALUES AND PLACING ITSELF IN EVERY  
ENVIRONMENT ALWAYS WITH THE UTMOST CARE.  
WHAT MATTERS TO US IS THAT THE CHAIR YOU  
CHOOSE REALLY BELONGS TO YOU AND REFLECTS  
100% THE IDEA YOU CARE ABOUT, THE ENVIRONMENT  
YOU WANT TO CREATE AND INHABIT. THIS IS WHY  
WE HAVE CONCEIVED A VERY HIGH CUSTOMIZATION  
PROPOSAL OF OUR PRODUCTS. WE ACCOMPANY  
YOU THROUGH A WORLD MADE OF FABRICS,  
MATERIALS AND STYLES TO CREATE YOUR CHAIR.

COLORI



## PIANI / TOPS

**Piani vetroceramica ceramic opachi /**  
Matt ceramic glass-ceramic tops



**Invisible white /**  
Invisible white

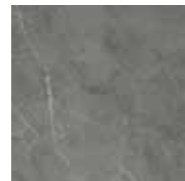

**Pietra grey /**  
Grey stone



**Marmo statuario venato /**Veined marble statuary

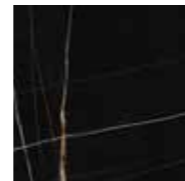

**Sahara Noir bocciardato /**Bush-hammered Sahara Noir



**Fokos sale /**  
Fokos salt



**Fokos roccia /**  
Fokos rock



**Fokos nero /**  
Fokos black

**Piani vetroceramica ceramic lucidi /**  
Glossy ceramic glass-ceramic tops

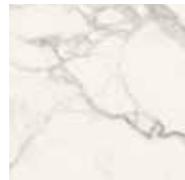

**Arabescato /**  
Arabesque



**Calacatta oro venato /**Veined golden Calacatta



**Emperador /**  
Emperador



**Noir Desir /**  
Noir Desir

**Piani vetro velvet opachi /**  
Matt velvet glass tops

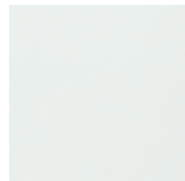

**A.V.XW. Extrabianco /**  
Extrawhite



**A.V.T. Tortora /**Taupe



**A.V.A. Antracite /**  
Anthracite



**A.V.N. Nero /**Black

**Piani vetro lucidi /**  
Glossy glass tops



**V.X.W. Extrabianco /**  
Extrawhite

## METALLI / METALS

**Metalli Luxury /**  
Luxury metals



**LUX.N.251 Nichel spazzolato /**  
Brushed nickel



**LUX.O.250 Oro spazzolato /**  
Brushed gold



**LUX.B.253 Bronzo spazzolato /**  
Brushed bronze



**LUX.R.254 Oro rosa /**Rose gold

**Metalli /**  
Metals

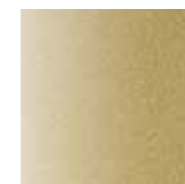

**M.G.647 Special Oro antico /**  
Antique gold



**M.T.610 Special Titanio /**  
Titanium



**M.O.33 Special Ottone /**  
Brass



**M.N.35 Special Nero /**Black

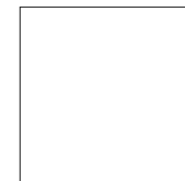

**B.O.206 Bianco opaco /**  
Matt white



**M.A.248 Antracite opaco /**  
Matt anthracite



**Multicolor Smart Bianco, titanio, ottone, antracite /**White, titanium, brass, anthracite

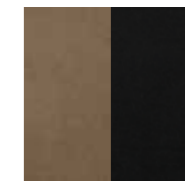

**Bicolor Ottone, nero /**  
Brass, black



**205 Cromo Cromato /**  
Chrome

I toni dei campioni sono da considerarsi indicativi / Sample colours are considered indicative



## LEGNI / WOODS

### Legni tinti / Stained woods



**RV.SB.25**  
**Frassino sbiancato /**  
Bleached ash

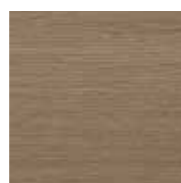

**RV.T.24**  
**Tabacco /**  
Tobacco



**RV.RO.38**  
**Royal Oak /**  
Royal Oak

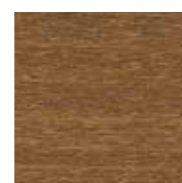

**RV.NC.22**  
**Noce canaletto /**  
Canaletto walnut

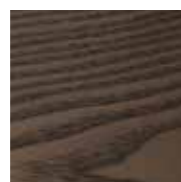

**RV.B.71**  
**Frassino bruciato**  
Burnt ash



**N.26**  
**Noce americano /**  
American walnut



**Tinta a campione**  
Sample dyed

### Legni laccati / Lacquered woods

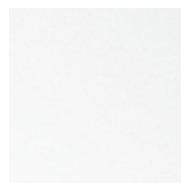

**Bianco / White**  
**RV.B.35 poro aperto**  
(open pore)  
**B.35 opaco** (matt)  
**B.L.35 lucido** (glossy)

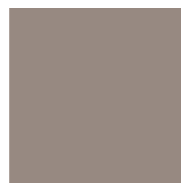

**Titanio Wood /**  
Wood titanium  
**RV.T.132 Poro aperto**  
(open pore)  
**T.132 Opaco** (matt)



**Ottone Wood /**  
Wood brass  
**RV.O.133 Poro aperto**  
(open pore)  
**O.133 Opaco** (matt)



**Antracite /**  
Anthracite  
**RV.A.138 Poro aperto**  
(open pore)  
**A.138 Opaco**  
(matt)



**Nero / Black**  
**RV.N.117 poro aperto**  
(open pore)  
**N.117 opaco** (glossy)



**Laccato a campione**  
**(scala RAL)**  
Sample lacquered  
(scale RAL)

## PIANI MELAMINICI / MELAMINE TOPS

### Piani melaminici Melamine tops

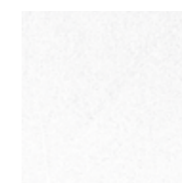

**27018**  
**Malta bianco /**  
White mortar



**AP2**  
**Malta tortora /**  
Taupe mortar



**34321**  
**Malta antracite /**  
Anthracite mortar

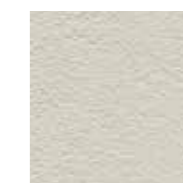

**DC8**  
**Calce / Lime**



**DA4**  
**Cemento / Cement**



**49H**  
**Ossido / Oxide**



**34217**  
**Tavolato bianco /**  
White plank

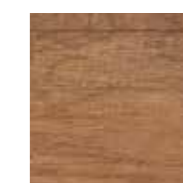

**988**  
**Tavolato Royal Oak /**  
Royal oak plank

I toni dei campioni sono da considerarsi indicativi / Sample colours are considered indicative



[www.friulsedie.it](http://www.friulsedie.it)



Friulsedie Sud s.r.l.  
Zona A.S.I. - Località Incoronata - 71122 - Foggia - Italy  
tel. +39 0881 680175 (r.a.) - fax +39 0881 680173  
[www.friulsediesud.it](http://www.friulsediesud.it) - [info@friulsediesud.it](mailto:info@friulsediesud.it)  
[www.friulsedie.it](http://www.friulsedie.it) - [info@friulsedie.it](mailto:info@friulsedie.it)



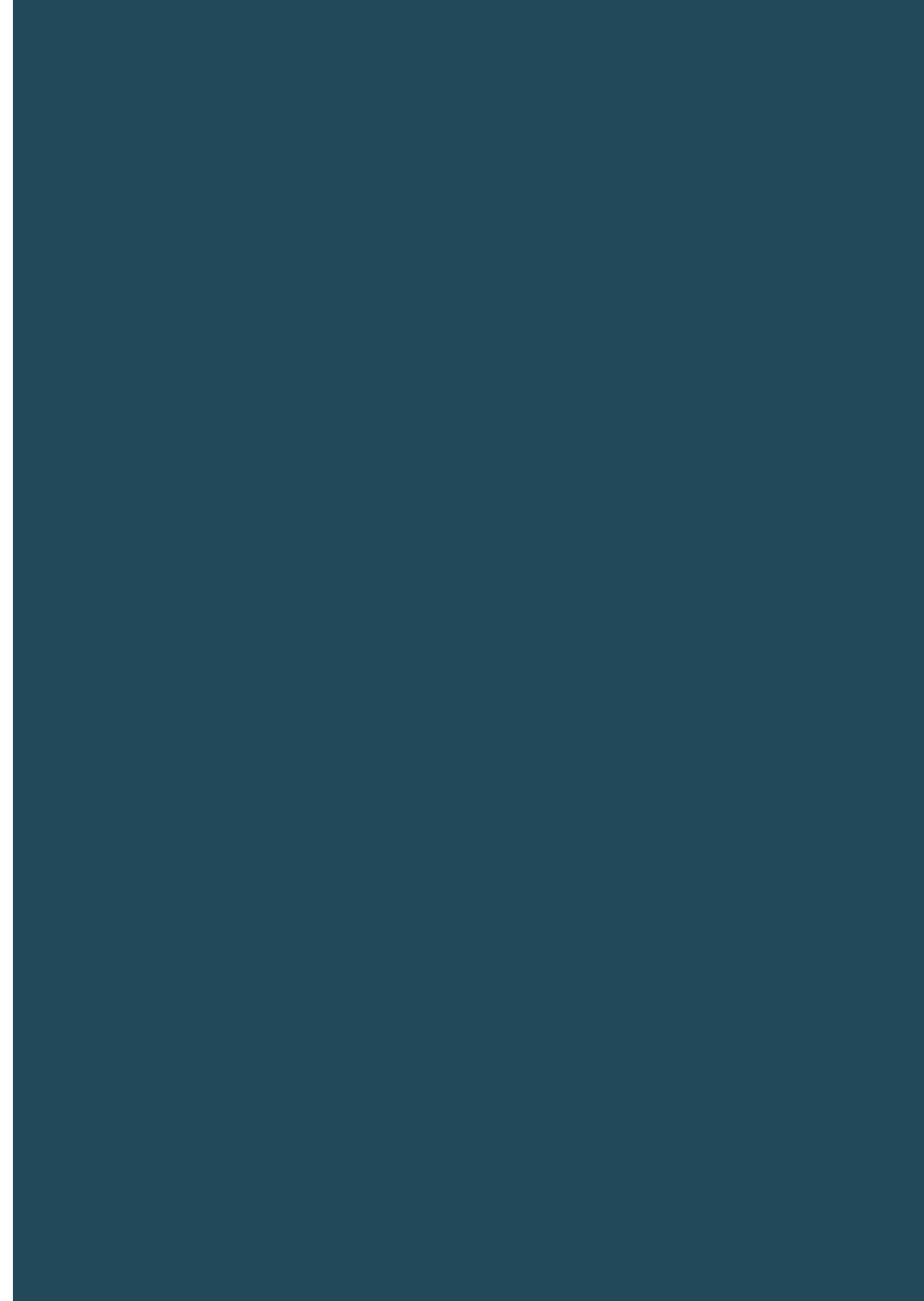



[www.friulsedie.it](http://www.friulsedie.it)



Friulsedie Sud s.r.l.  
Zona A.S.I. - Località Incoronata - 71122 - Foggia - Italy  
tel. +39 0881 680175 (r.a.) - fax +39 0881 680173  
[www.friulsediesud.it](http://www.friulsediesud.it) - [info@friulsediesud.it](mailto:info@friulsediesud.it)  
[www.friulsedie.it](http://www.friulsedie.it) - [info@friulsedie.it](mailto:info@friulsedie.it)