

*Lightness  
of living*

Outdoor Book

---

POTOCCO  
ITALY

POTOCCO  
ITALY



— La cultura artigianale come patrimonio aziendale ci ha permesso negli anni di coniugare i vantaggi di una produzione moderna con la cura del dettaglio tipica delle lavorazioni manuali. Dopo un secolo di storia, realizziamo ancora internamente tutte le fasi produttive comprese le più delicate, come il tradizionale intreccio a mano. Il risultato sono prodotti per indoor e outdoor di qualità superiore, capaci di raccontare una storia fatta di tradizione, cura e innovazione.

**UNA QUALITÀ SENZA COMPROMESSI  
UNCOMPROMISING QUALITY IS OUR MISSION**

The artisan culture as a corporate asset has allowed us to combine, over the years, the advantages of a modern production with the attention to detail, typical of manufacturing. After over a century of history, we still manage

internally all the production phases, including the most delicate ones, such as the traditional hand weaving. The result are superior quality indoor and outdoor products, able to tell a story made of tradition, care, and innovation.







Ritratto di famiglia. Antonino Potocco con le figlie Alice e Marianna.  
*Family portrait. Antonino Potocco with his daughters Alice and Marianna.*



# Family is our starting point.

Le donne intrecciavano  
le sedie durante le pause dal lavoro.  
*Women made chairs straw  
bottoming during their work breaks.*

Potocco è tra le aziende  
fondatrici del Salone del Mobile.  
*Potocco is a co-founder of  
Salone del Mobile.*

3rd - generation  
Grazie a Valerio Potocco e a suo figlio  
Antonino l'azienda diventa Potocco Sp.A.  
*Thanks to Valerio Potocco and his son  
Antonino the company becomes Potocco Sp.A.*

4th - generation  
Antonino Potocco diventa  
Presidente della Potocco Sp.A.  
*Antonino Potocco becomes  
President of Potocco Sp.A.*

5th - generation  
Apertura della Potocco Asia Pacific  
Division. Antonino Potocco guida  
l'azienda con le figlie Alice e Marianna.  
*Opening of Potocco Asia Pacific Division.  
Antonino Potocco runs the company along  
with his daughters Alice and Marianna.*

Acquisizione di un nuovo  
reparto di imbottiti.  
*Acquisition of a new  
upholstery department.*

— 1919 —  
1st - generation  
Domenico Potocco dà vita ad una piccola  
bottega artigiana per la produzione di sedie.  
*Domenico Potocco starts a small artisan  
workshop for the production of chairs.*

1931 —  
— 1951 —  
2nd - generation  
Antonio Potocco entra in azienda  
assieme a suo figlio Valerio.  
*Antonio Potocco joins the company  
with his son Valerio.*

1961 —  
— 1970 —  
Potocco non è più solo un'azienda  
produttrice ma inizia a disegnare e  
creare le proprie collezioni di prodotti.  
*Potocco is no longer just a supplier  
but begins to design and create its own  
products' collections.*

1980 —  
— 1999 —  
Ampliamento degli uffici. Superficie  
totale di 50.000 mq, 25.000 mq di  
capannoni e 500 mq di showroom.  
*Office expansion. Overall surface of  
50.000 sqm with a surface of sheds of  
25.000 sqm and 500 sqm of showroom space.*

2000 —  
— 2015 —  
Apertura di Potocco USA.  
*Opening of Potocco USA.*

2016 —  
— 2019 —  
Potocco festeggia 100 anni.  
*Potocco celebrates its 100th anniversary.*

2022 —



— Il nostro punto di forza è da sempre la grande capacità di personalizzazione offerta al cliente: grazie a una produzione gestita internamente e all'abilità nella lavorazione dei materiali, siamo in grado di realizzare su misura ogni proposta, customizzandola sulla base di specifiche richieste.

Our strength has always been the great ability of customization offered to the customer: thanks to an internally managed production and to the ability to process materials, we are able to tailor each proposal, customizing it based on specific requests.



L'expertise maturata in oltre un secolo d'attività si manifesta nell'estrema attenzione per i dettagli, tipica della tradizione artigianale. I nostri prodotti da outdoor confermano l'estetica sofisticata e la cura sartoriale della nostra collezione indoor, grazie alla magistrale capacità nel selezionare e trattare i materiali destinati all'esterno: dal legno agli imbottiti, dai rivestimenti in tessuto al prezioso intreccio a mano.

The expertise gained in more than a century of activity is manifested in the extreme attention to details, typical of traditional craftsmanship. Our outdoor products confirm the sophisticated aesthetics and sartorial care of our indoor collection, thanks to the masterful ability to select and treat materials for outdoor use: from wood to upholstery, from fabric upholstery to precious hand weaving.



Bespoke  
is  
our  
state  
of  
mind.

# INDEX

028 Soul family, 048 Double L coffee tables,  
 054 Sophie dining table, 064 Ola family,  
 088 Weld coffee tables, 098 Elodie sofa system,  
 104 Butler trolley, 108 Alyza dining chairs,  
 118 Ropu family, 128 Herm poufs,  
 132 Otx dining table, 142 Katana dining table,  
 150 Little T coffee tables, 160 Keel light family,  
 170 Keel family, 184 Hishi coffee tables,  
 188 Agra family, 208 Tibes family, 224 Clue rugs,  
 240 Cut lounge, 252 Loom sofa system,  
 264 Egao family, 272 Vela family,  
 284 Velis dining chair, 290 Suno sunbed.

## Sedie e poltroncine / Chair and armchairs



**AGRA**  
 Art. 688/XXL  
 pag. 133, 135, 190-191,  
 195, 199, 200



**AGRA**  
 Art. 688/PXXL  
 pag. 133, 190-191, 199, 201



**ALYZA**  
 Art. 948  
 pag. 109, 110, 112, 113,  
 142, 147, 148-149



**ALYZA**  
 Art. 948/P  
 pag. 111, 112, 113,  
 142, 147, 148-149



**EGAO**  
 Art. 037  
 pag. 54, 268-269, 270-271



**EGAO**  
 Art. 037/P  
 pag. 268-269, 270-271



**EGAO**  
 Art. 037/PBR  
 pag. 54, 59, 268-269



**KEEL**  
 Art. 922-OUT  
 pag. 171, 172, 174-175, 176-177



**KEEL**  
 Art. 922/P-OUT  
 pag. 171, 174-175, 176-177



**KEEL LIGHT**  
 Art. 922/MB-OUT  
 pag. 166-167, 168



**KEEL LIGHT**  
 Art. 922/PMB-OUT  
 pag. 166-167



**OLA**  
 Art. 923  
 pag. 74-75, 80, 83



**OLA**  
 Art. 923/P  
 pag. 74-75, 83



**OLA**  
 Art. 923/P-IMP  
 pag. 57, 76, 79, 83



**OLA**  
 Art. 923/PMF  
 pag. 70, 71, 72, 73



**TIBES**  
 Art. 945  
 pag. 214, 216-217, 218, 219



**VELA**  
 Art. 698  
 pag. 273, 274-275, 276-277



**VELA**  
 Art. 698/P  
 pag. 274-275, 276-277



**VELIS**  
 Art. 942/PAR-OUT  
 pag. 284, 286, 287, 288



Sgabelli / Stools



**AGRA**  
Art. 688/S  
pag. 202-203



**AGRA**  
Art. 688/A  
pag. 202-203



**EGAO**  
Art. 037/A  
pag. 264, 267



**KEEL**  
Art. 922/S-OUT  
pag. 172, 182-183



**KEEL**  
Art. 922/A-OUT  
pag. 172, 180, 182-183



**KEEL LIGHT**  
Art. 922/SMB-OUT  
pag. 138, 164



**KEEL LIGHT**  
Art. 922/AMB-OUT  
pag. 138, 164



**OLA**  
Art. 923/S  
pag. 86-87



**OLA**  
Art. 923/A  
pag. 82, 84-85, 86-87



**TIBES**  
Art. 945/S  
pag. 220, 222, 223



**TIBES**  
Art. 945/A  
pag. 220, 222, 223



**VELA**  
Art. 698/S  
pag. 283



**VELA**  
Art. 698/A  
pag. 283

Poltrone / Lounge chairs



**CUT**  
Art. 910/PLR  
pag. 241, 242-243, 245, 246-247



**ELODIE**  
Art. 908/PL-OUT  
pag. 98, 100-101



**KEEL**  
Art. 922/L-OUT  
pag. 122, 174-175, 178, 179



**KEEL LIGHT**  
Art. 922/LMB-OUT  
pag. 160, 163



**LOOM**  
Art. 880/PR-OUT  
pag. 252, 255



**OLA**  
Art. 923/PL  
pag. 64, 66-67, 68



**SOUL**  
Art. 960/P  
pag. 28, 30-31, 34-35, 36-37



**TIBES**  
Art. 945/L  
pag. 50, 208, 210-211, 212, 213



**VELA**  
Art. 698/LP  
pag. 280

Pouf / Poufs



**CUT**  
Art. 910/PPR  
pag. 241, 242-243, 246-247



**HERM**  
Art. 925/O80-OUT  
pag. 128, 130-131



**HERM**  
Art. 925/O45-OUT  
pag. 130-131



**HERM**  
Art. 925/O60-OUT  
pag. 130-131



**ROPU**  
Art. 888/CQR-OUT  
pag. 118, 120-121, 123, 127



**SOUL**  
Art. 960/O  
pag. 36-37



Divani / Sofas



**ELODIE**  
Art. 908/D-OUT  
pag. 100-101, 102, 103



**LOOM**  
Art. 880/DR-OUT, DR-200-OUT  
pag. 256-257, 258-259

Tavoli / Tables



**AGRA**  
Art. 688/ATG-O  
pag. 74-75, 188, 190-191, 192-193, 195, 196, 197



**KATANA**  
Art. 026/TC3-OUT  
pag. 144-145



**KATANA**  
Art. 026/TR4-OUT  
pag. 71, 72, 142, 147, 148-149, 216-217



**LOOM**  
Art. 880/DRL-OUT, DRM-OUT  
pag. 256-257, 262-263



**OLA**  
Art. 923/D  
pag. 66-67, 69



**OTX**  
Art. 887/TGC  
pag. 112, 113, 133, 135, 136-137, 284



**OTX**  
Art. 887/TC  
pag. 136-137, 140-141, 270-271



**OTX**  
Art. 887/TQ  
pag. 288



**SOUL**  
Art. 960/D  
pag. 28, 32, 33, 34-35



**VELA**  
Art. 698/D  
pag. 278, 279



**OTX**  
Art. 887/TSC  
pag. 136-137, 140-141, 283



**OTX**  
Art. 887/TSQ  
pag. 138, 140-141, 164



**OTX**  
Art. 887/TAC  
pag. 84-85, 136-137, 223

Daybed & Lettini / Daybeds & Sunbeds



**LOOM**  
Art. 880/DB-OUT  
pag. 260



**SOUL**  
Art. 960/CL  
pag. 42, 45, 46-47



**SUNO**  
Art. 895/D-RECL  
pag. 291, 292-293, 294-295



**OTX**  
Art. 887/TAQ  
pag. 138, 140-141, 164



**SOPHIE**  
Art. 951/T  
pag. 54, 56, 57, 59, 166-167

Tavolini / Coffee tables



**DOUBLE L**  
Art. 952/TC-OUT  
*pag. 28, 30-31, 32, 34-35, 38, 42, 46-47, 49, 50, 52, 53, 210-211*



**HISHI**  
Art. 871/TBC-OUT  
*pag. 179, 185, 186-187*



**HISHI**  
Art. 871/TBQ-OUT  
*pag. 186-187*



**LITTLE T**  
Art. 878/TQ-50-OUT  
*pag. 66-67, 152-153, 252*



**BUTLER**  
Art. 892  
*pag. 105, 106, 292-293*



**LITTLE T**  
Art. 878/TQ-100-OUT  
*pag. 100-101, 120-121, 150, 152-153, 154, 155*



**LITTLE T**  
Art. 878/TR-OUT  
*pag. 66-67, 100-101, 150, 152-153, 154, 155*



**ROPU**  
Art. 888/TBC-OUT  
*pag. 120-121, 122, 124-125, 163, 256-257*



**ROPU**  
Art. 888/TBR-OUT  
*pag. 124-125, 256-257*



**SOUL**  
Art. 960/TQ, TR  
*pag. 28, 34-35, 38, 40, 41*



**WELD**  
Art. 865/TCB  
*pag. 64, 66-67, 88, 90-91, 92-93, 98, 120-121*



**WELD**  
Art. 865/TCH  
*pag. 90-91, 92-93, 98, 100-101*

Accessori / Accessories

Tappeti / Carpets



**CLUE**  
Art. 971/C  
*pag. 122, 133, 135, 199, 226-227, 228, 229, 230, 232, 233, 236-237*

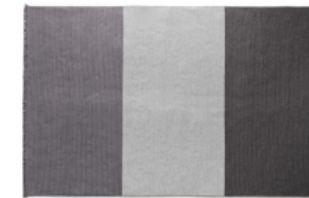

**CLUE**  
Art. 971/R  
*pag. 100-101, 102, 103, 120-121, 154, 155, 160, 163, 224, 226-227, 232, 233, 234, 235, 238, 239*

# Episodes

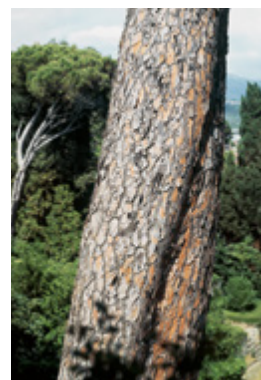

I. pag. 24/59



II. pag. 60/93



III. pag. 94/113



IV. pag. 114/155



V. pag. 156/203

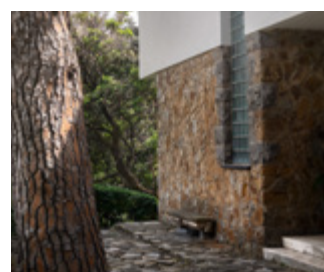

VI. pag. 204/247



VII. pag. 248/295

Il dialogo armonioso tra gli oggetti e la natura circostante prende forma in un racconto composto da sette episodi. La vita all'aria aperta diventa simbolo di un nuovo modo di abitare.

The harmonious dialogue between the objects and the surrounding nature takes shape in a story made of seven episodes. Outdoor life becomes a symbol of a new way of living.





Episode

**I.**

Pleasant leisure

Soul family / Double L coffee tables / Sophie dining table



— Incastonato tra le rocce, lontano da occhi indiscreti, un angolo di natura congiunge la baia con l'orizzonte urbano. La ricchezza della vegetazione fa da cornice e rifugio dello spazio abitativo. Un inno alla bellezza celata, che si mostra nel suo splendore soltanto agli occhi di chi sa coglierla.

Set among the rocks, far from prying eyes, a corner of nature ties the bay with the urban horizon. The abundance of vegetation frames and shelters the living space. An ode to the hidden beauty, that reveals its splendor only to the eyes of those who can grasp it.





# Soul family

— Soul è una collezione di sedute e tavolini che nasce dall'intento di creare un sistema modulare agile e avvolgente. Divani, poltrone e chaise longue sono caratterizzati dall'intreccio dello schienale e dei braccioli, oltre che da pianali modulari con cuscini in appoggio. La modularità del telaio consente di strutturare tutti gli elementi in composizioni chiuse, bifacciali o angolari. La struttura è caratterizzata dal dettaglio che unisce gli elementi. Questa si sviluppa anche nel disegno dei tavolini, disponibili in varie dimensioni e top, sia quadrati che rettangolari.

Soul is a collection of seats and coffee tables, born from the intent to create an agile and enveloping modular system. Sofas, lounge chairs, and chaise longues are characterized by the interweaving of the backrest and armrests, as well as modular platforms with cushions in support. The modularity of the frame allows you to structure all elements in double-sided or corner compositions. The structure is characterized by the detail that unites the elements. This also develops in the design of the coffee tables, available in various sized and tops, both square and rectangular.







Soul 960/P, Poltrone / *Lounge chairs*  
Double L 952/TC-OUT, Tavolino / *Coffee table*





Dettaglio intreccio bracciolo / *Armrest's weaving detail*











Soul 960/O - 960/P  
Pouf e poltrona / *Pouf and lounge chair*





Soul 960/TQ-960/TR, Tavolini / *Coffee tables*  
Double L 952/TC-OUT, Tavolino / *Coffee table*



Dettaglio piano frassino waterproof / *Waterproof ash top detail*















Soul 960/CL, Chaise longue / *Chaise longue*  
Double L 952/TC-OUT, Tavolino / *Coffee table*



# Double L

## /coffee tables

— Il tavolino Double L, ideale da posizionare di fianco a un divano o in sormonto con altri tavolini, è costituito da due gambe in lamiera d'acciaio nero goffrato, unite da un elemento centrale, nella stessa finitura, che diventano due segni grafici, sulle quali poggia il piano in pietra naturale light grey o grès porcellanato ossido nero.

The Double L coffee table, ideal to be placed next to a sofa or overlapping other coffee tables, consists of two legs in embossed black steel sheet, joined by a central element, in the same finish, which become two graphic signs, on which rests the top in light grey natural stone or black oxide laminated porcelain.



Double L 952/TC-OUT  
Tavolino / Coffee table





Double L 952/TC-OUT, Tavolino / *Coffee table*  
Tibes 945/L, Poltrona / *Lounge Chair*





Double L.952/TC-OUT  
Tavolini con piano in pietra naturale o grès porcellanato / *Coffee tables with light grey natural stone or black oxide laminated porcelain top*



# Sophie

/dining table

— Il generoso tavolo da outdoor Sophie si compone di una base ottagonale in acciaio verniciato a polveri epossidiche rivestito in corda nautica color canapa oppure “Gassa” testa di moro, su cui si appoggia un piano in frassino waterproof, oppure in pietra naturale light grey.

The generous Sophie outdoor table consists of an octagonal base painted with epoxy powder coated steel covered in hemp or dark brown “Gassa” rope, on which rests a waterproof ash or light grey natural stone top.



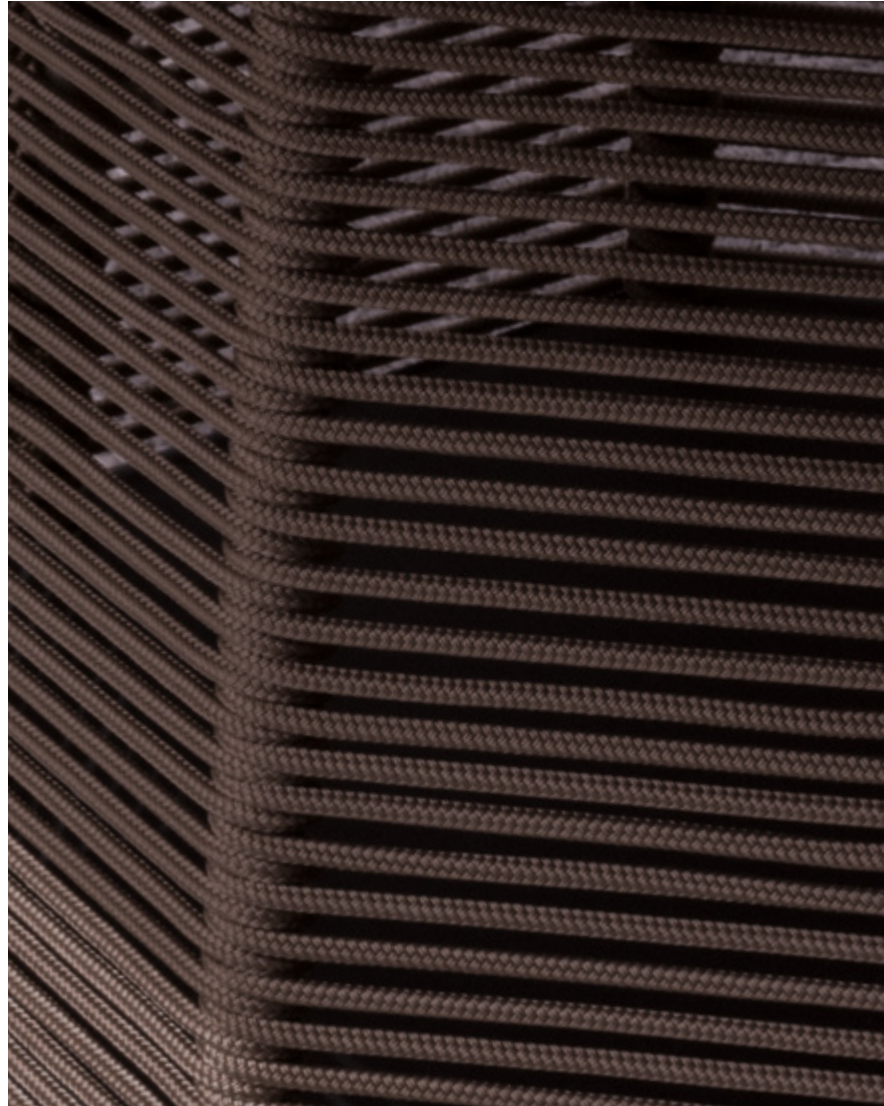









Episode

**II.**

Glimmers of sunshine

Ola family / Weld coffee tables



— Il sole si specchia nell'acqua che circonda il promontorio, mentre le onde restituiscono riflessi caldi che si propagano sull'orizzonte. I frammenti brillanti delineano gli arredi creando scenari suggestivi in cui lo spazio diventa dinamico. Risultato di un dialogo incessante e reciproco tra luce e ombra.

Rays of sun mirror in the water surrounding the bay, and the waves give back warm reflections of light spreading over the horizon. Bright glimmers outline the objects, drawing suggestive scenarios where space becomes dynamic, resulting in a perpetual and mutual dialogue between light and shadow.







## Ola family

— La famiglia di sedute Ola, composta da divano, poltrona, sedia impilabile, poltroncina, poltroncina impilabile, poltroncina pozzetto e sgabelli a due altezze, si caratterizza per la forma dello schienale avvolgente, in tondino di metallo, che ricorda l'immagine fluida dell'onda. La struttura è interamente intrecciata a mano in fettuccia "Fly". Completa le sedute un morbido Cuscino removibile e sfoderabile.

The Ola seating family, composed by sofa, lounge chair, stackable chair, armchair, stackable armchair, tub armchair and two-height stools, is characterized by the shape of the enveloping backrest, in metal rod, reminiscent of the fluid image of the wave. The structure is entirely hand-woven in "Fly" ribbon. To complete the seats a soft detachable and removable cushion.







Ola 923/PL  
Poltrona / *Lounge chair*



Ola 923/D  
Divano / *Sofa*



Dettaglio intreccio schienale / *Backrest's weaving detail*



Ola 923/PMF, Poltroncine pozzetto / *Tub chairs*  
Katana 026/TR4-OUT, Tavolo / *Table*









Ola 923-923/P, Sedie e poltroncina / *Chairs and armchair*  
Agra 688/ATG-O, Tavolo / *Table*





Ola 923/P-IMP  
Poltroncine impilabili / *Stackable armchairs*









Ola 923  
Sedia impilabile / *Stackable chair*



Ola923/A  
Sgabello alto / *Barstool*











Ola 923/A - 923/S  
Sgabello alto e sgabello basso / *Barstool and counterstool*





# Weld

## /coffee tables

— Weld è una famiglia di tavolini disponibili in due altezze e dimensioni composta da una base in metallo verniciato e dettagli in corda nautica o “Gassa” con piano circolare in hpl, grès porcellanato, massello di iroko o frassino waterproof.

Weld is a family of coffee tables available in two heights and sizes consisting of a painted metal base and details in nautical rope or dark brown “Gassa” rope with circular top in hpl, laminated porcelain, solid iroko wood or waterproof ash wood.





Weld 865/TCB - 865/TCH  
Tavolini / *Coffee tables*





Weld 865/TCB - 865/TCH  
Tavolini / *Coffee tables*





Episode

**III.**

Quiet shadows

Elodie sofa system / Butler trolley / Alyza dining chairs



— Una danza di luci e di ombre, di pieni e di vuoti che vengono definiti dalla natura, dal movimento terrestre e dalla mano dell'uomo. Un alternarsi di sculture naturali, modellate dal tempo e dal vento, e oggetti e architetture plasmate dall'ingegno. Un incontro enigmatico che si risolve armoniosamente all'ombra di alberi secolari.

A dance of lights and shadows, solids and voids that are defined by nature, the earth's movement, and the hand of man. An alternation of natural sculptures, shaped by the time and the wind, and objects and architectures shaped by ingenuity. An enigmatic encounter that is harmoniously resolved in the shade of ancient trees.

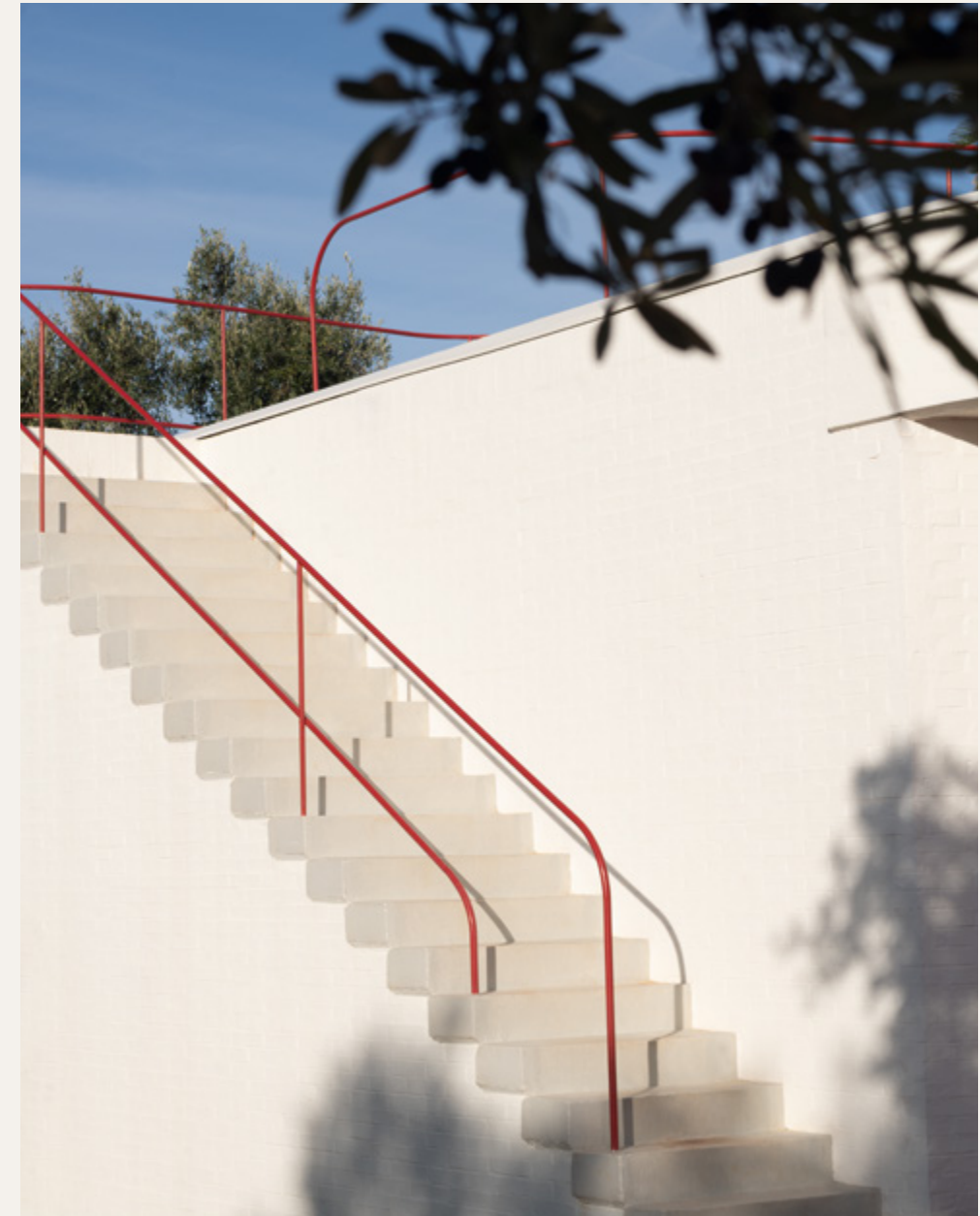



# Elodie

## /sofa system

— Il divano a due posti e la poltrona Elodie sono caratterizzati da una struttura essenziale in metallo a vista. Ampii cuscini poggiano su una lama piatta in metallo che corre tutta intorno alla cuscineria sorreggendola. Il dettaglio distintivo risiede nell'imbottitura della seduta, che grazie a dei particolari sostegni si distacca dalla struttura stessa risultando sospesa.

The Elodie two-seater sofa and lounge chair are characterized by an essential structure in exposed metal. Large cushions rest on a flat metal blade that runs all around the cushions supporting it. A distinctive detail lies in the upholstery of the seat, which thanks to special supports detaches itself from the structure resulting suspended.





Elodie 908/PL-OUT - Elodie 908/D-OUT, Poltrona e divano / Lounge chair and sofa | Weld 865/TCH, Tavolino / Coffee table  
Little T 878/TR-OUT - 878/TQ-100-OUT, Tavolini / Coffee tables | Clue 971/RBEIGE Tappeto / Carpet





Dettaglio bracciolo / *Armrest's detail*





# Butler

## /trolley

— Butler è un carrello da esterno, ideale per organizzare, trasportare e contenere cibo, stoviglie e altri oggetti. Il piano superiore in massello di iroko, insieme a quello inferiore e al contenitore portabottiglie in metallo, removibile secondo esigenza, creano un gioco di volumi e linee con la struttura.

Butler is an outdoor trolley, ideal for organizing, transporting, and containing food, dishes, and other objects. The upper top in solid iroko wood, together with the lower one and the metal bottle container, removable as needed, create a play of volume and lines with the structure.









# Alyza

## /dining chairs

— La famiglia Alyza, composta da sedia e poltroncina dining si identifica per i tratti raffinati e rigorosi, adatta ad ogni tipo di collocazione, sia domestica che contract. La struttura è in tondino di acciaio verniciato a polveri epossidiche per outdoor. Il cuscino della seduta è in poliuretano integrale autopellante.

The Alyza family, composed of dining chair and armchair, is identified by its refined and rigorous features, suitable for any type of location, both domestic and contract. The structure is in epoxy powder coated steel rod for outdoor. The seat cushion is made of self-skinning integral polyurethane.



Alyza 948  
Sedia / Chair





Alyza 948  
Sedia / *Chair*

Alyza 948/P  
Poltroncina / *Armchair*







Alyza 948 - 948/P, Sedie e poltroncine / *Chairs and armchairs*  
OTX 887/TGC, Tavolo / *Table*

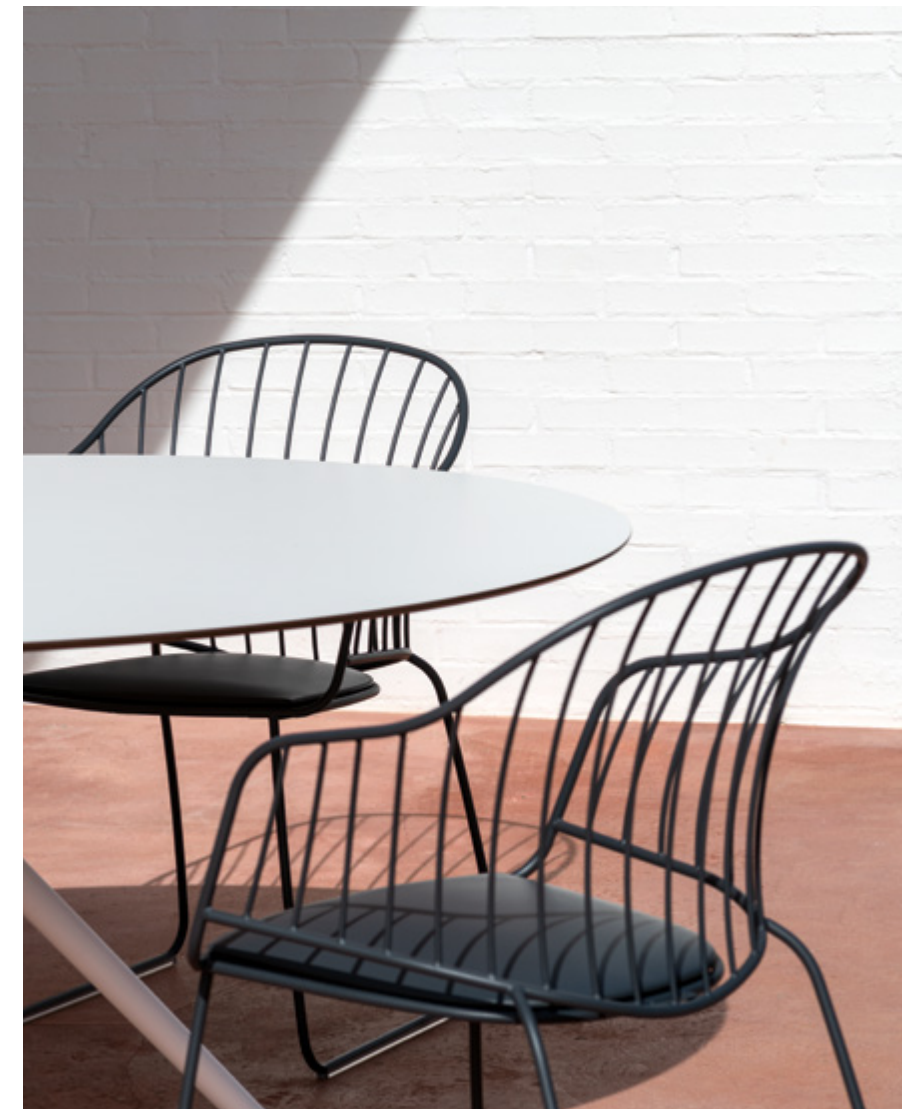





Episode  
**IV.**

Scents of simplicity

Ropu family / Herm poufs / Otx dining table / Katana dining table / Little T coffe tables



— Caleidoscopio di sfumature naturali, crocevia di profumi, incontro di emozioni pure. Una bellezza autentica che fa della quiete il suo linguaggio, dialogando armoniosamente con l'ambiente circostante. Arredi studiati per entrare in punta di piedi confondendosi con le nuances della natura. Angoli da vivere, chiudendo gli occhi e abbracciando il fluire del tempo.

Kaleidoscope of natural shades, crossroads of perfumes, meeting of pure emotions. An authentic beauty that makes of quiet its language, dialoguing harmoniously with the surrounding environment. Furnishings designed to tiptoe into the nuances of nature. Corners to live, closing your eyes and embracing the flow of time.





## Ropu family

— Dalle rimembranze esotiche, Ropu si distingue per la bordatura intrecciata a mano in cordino "Gassa", che corre lungo il perimetro creando una cornice per il top in grès porcellanato e hpl oppure soffici cuscini con profili a coda di topo. Con base a quattro gambe in metallo, la collezione è disponibile nella versione tavolino basso con piano rettangolare o alto con piano circolare e pouf rettangolare, da abbinare in libere composizioni.

With exotic remembrances, Ropu stands out for its hand-woven edging in "Gassa" rope, which runs along the perimeter creating a frame for laminated porcelain and hpl tops or soft cushions with mousetail profiles. With a four-leg metal base, the collection is available in the low coffee table with rectangular top or high coffee table with circular top and rectangular pouf, to be combined in free compositions.





Ropu 888/CQR-OUT - 888/TBC-OUT, Pouf e tavolino / *Poufs and coffee table*  
Weld 865/TCB | Little T 878/TQ-100-OUT, Tavolini / *Coffee tables* | Clue 971/R BEIGE Tappeto / *Carpet*





Dettaglio intreccio profilo / Profile's weaving detail







Ropu 888/TBC-OUT - 888/TBR-OUT  
Tavolini / *Coffee tables*





Ropu 888/CQR-OUT  
Pouf / *Pouf*



# Herm

## /poufs

— Un dettaglio sartoriale contraddistingue il pouf Herm: una fascia in tessuto con cuciture a vista lo circonda creando raffinati plissé. È dotata di una pratica maniglia, che ne agevola lo spostamento. Proposto in tre diverse forme, Herm è disponibile sia nella versione indoor, per creare diverse composizioni in un interno domestico, sia nella variante outdoor, per personalizzare terrazze e giardini.

A sartorial detail distinguishes the Herm pouf: a fabric belt with visible stitching surrounds it, creating refined pleats. It is equipped with a practical handle, which makes it easy to move. Available in three different shapes, Herm is available both in the indoor version, to create different compositions in a domestic interior, and in the outdoor variant, to customize terraces and gardens.





Herm 925/O45-OUT - 925/O60-OUT - 925/O80-OUT  
Pouf / Poufs



# Otx

## /dining table

— Versatili e dal design essenziale i tavoli OTX con gamba centrale e quattro piedini, sono caratterizzati da un piano reclinabile verticalmente in hpl, circolare o quadrato, in dimensioni differenti, per poterli accostare uno accanto all'altro. Estremamente funzionali, sono inoltre proposti in tre altezze per diversi utilizzi: da spazi collettivi a bar, da giardini a terrazze. OTX è inoltre proposto nella versione dining fissa Ø128 e Ø158 cm, con base in metallo verniciata e piano in hpl.

Versatile and with an essential design, the OTX tables with central leg and four feet, are characterized by a vertically reclining top in hpl, circular or square, in different sizes, to be able to place them side by side. Extremely functional, they are also available in three heights for different uses: from collective spaces to bars, from gardens to terraces. OTX is also available in the fixed dining version Ø128 and Ø158 cm, with painted metal base and hpl top.





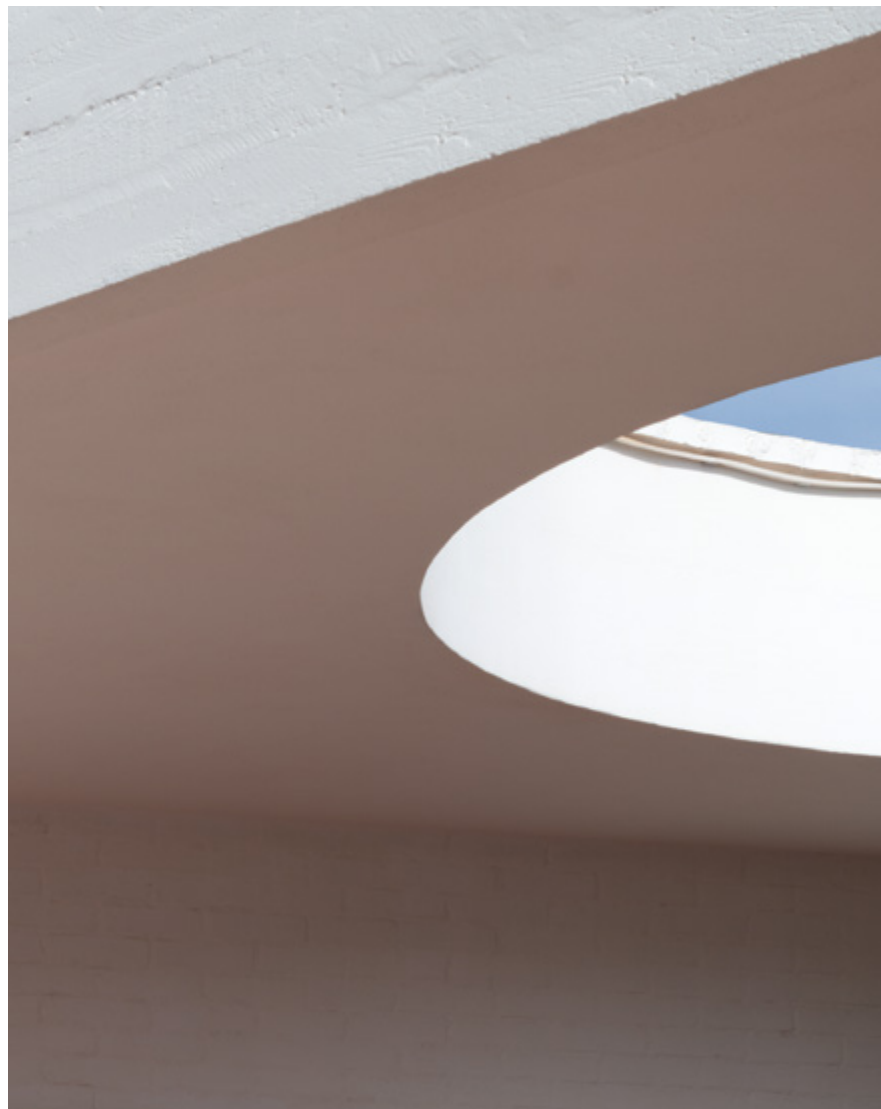

OTX 887/TGC, Tavolo / *Table* | Clue 971/C BEIGE, Tappeto / *Carpet*  
Agra 688/XXL, Sedia / *Chair*





OTX 887/TC - 887/TAC - 887/TGC - 887/TSC  
Tavoli / Tables





OTX 887/TAQ, Tavolo / *Table*  
Keel Light 922/AMB-OUT, Sgabelli alti / *Barstools*





OTX 887/TSC - 887/TC - 887/TAQ - 887/TC  
Tavoli / Tables



# Katana

## /dining table

— A decretare l'unicità del tavolo Katana è il peculiare disegno delle gambe in metallo, che richiama le antiche spade giapponesi a lama curva dalle quali il prodotto prende il nome. Proposta versatile, Katana è un tavolo pensato per adattarsi ai contesti all'aria aperta, proposto sia in una versione a tre gambe con piano circolare, sia in una rettangolare a quattro gambe, entrambe con piano in grès porcellanato o hpl.

The uniqueness of the Katana table is declared by the peculiar design of the metal legs, which recall the ancient Japanese curved blade swords from which the product takes its name. Versatile proposal, Katana is a table designed to adapt to outdoor contexts, available both in a three-legged version with circular top, and in a rectangular version with four legs, both with laminated porcelain or hpl top.













Katana 026/TR4-OUT, Tavolo / *Table*  
Alyza 948 - 948/P, Sedie e poltroncine / *Chairs and armchairs*



# Little T

## /coffee tables

— La rigorosa struttura in metallo goffrato anima il disegno dei tavolini Little T. Proposti in tre dimensioni e altezze diverse, i tavolini sono ideali come piano d'appoggio fianco e fronte divano o per creare differenti composizioni. Con piano in grès porcellanato o pietra naturale, sono pensati per l'utilizzo sia in ambito domestico che contract.

The rigorous embossed metal structure animates the design of the Little T coffee tables. Available in three different sizes and heights, these coffee tables are ideal as side or front sofa tables, or to create different compositions. With top in laminated porcelain or light grey natural stone, they are designed for both domestic and contract environments.





Little T 878/TQ-100-OUT - 878/TR-OUT - 878/TQ-50-OUT  
Tavolini / *Coffee tables*





Little T 878/TQ-100-OUT - 878/TR-OUT, Tavolini / *Coffee tables*  
Clue 971/R GREY, Tappeto / *Carpet*





Episode

**V.**

Winds of freedom

Keel light family / Keel family / Hishi coffee tables / Agra family



— Il cielo leggermente terso, una luce sinuosa che scolpisce gli elementi della natura come fossero personaggi secondari di un romanzo. Oggetti avvolgenti che assolvono la funzione nobile e rara di essere spettatori silenziosi di attimi di intima riflessione. Le ombre che si fanno lunghe, la vita che scorre, lenta come il suono delle foglie degli ulivi.

The slightly clear sky, a sinuous light that sculpts the elements of nature as if they were secondary characters of a novel. Enveloping objects that perform the noble and rare function of being silent spectators of moments of intimate reflection. The shadows that become long, the life that flows, slowly as the sound of the leaves of the olive trees.







## Keel light family

— La famiglia Keel Light composta da sedia e poltroncina dining, poltrona e sgabelli a due altezze, nasce da una ricerca sul tema del rapporto tra rigore geometrico e sinuosità organica. Keel Light, ampliamento della collezione Keel, si differenzia per il suo guscio sotto sedile verniciato che rimanda al mondo della nautica, rappresentando infatti il tentativo di trovare il miglior equilibrio tra una struttura lineare in tondino di metallo ed elementi d'appoggio in massello di iroko dalle forme morbide e sinuose che presentano una lavorazione molto particolare.

The Keel Light family, consisting of dining chair and armchair, lounge chair and two-height stools, was born from the research of the relationship between geometric rigor and organic sinuosity. Keel Light, an extension of the Keel collection, differs from it for its painted underlying shell that refers to the nautical world, representing the attempt to find the best balance between a linear structure in metal rod and supporting elements in solid iroko wood with soft and sinuous shapes that present a very special process.





Keel Light 922/LMB-OUT, Poltrone / *Lounge chairs*  
Cluc 971/RPETROL, Tappeto / *Carpet* | Ropu 888/TBC-OUT, Tavolino / *Coffee table*





Keel Light 922/AMB-OUT, Sgabello alto / *Barstool*  
OTX 887/TAQ, Tavolo / *Table*











Keel Light 922/MB-OUT  
Sedia / *Chair*



# Keel family

— La famiglia Keel composta da sedia e poltroncina dining, poltrona e sgabelli a due altezze, nasce da una ricerca sul tema del rapporto tra rigore geometrico e sinuosità organica. Keel, che si differenzia dalla collezione Keel light per la seduta interamente imbottita, rimanda al mondo della nautica, rappresentando il tentativo di trovare il miglior equilibrio tra una struttura lineare in tondino di metallo ed elementi d'appoggio in massello di iroko dalle forme morbide e sinuose che presentano una lavorazione molto particolare.

The Keel family, consisting of dining chair and armchair, lounge chair and two-height stools, was born from the research of the relationship between geometric rigor and organic sinuosity. Keel, which differs from the Keel light collection by the fully upholstered seat, refers to the nautical world, representing the attempt to find the best balance between a linear structure in metal rod and supporting elements in solid iroko wood with soft and sinuous shapes that present a very special process.



Keel 922/OUT - 922/P-OUT  
Sedie e poltroncina / *Chairs and armchair*





Keel 922/OUT - 922/A-OUT - 922/S-OUT  
Sedia, sgabello alto e sgabello basso / *Chair, barstool and counterstool*





Keel 922/OUT - 922/L-OUT - 922/P-OUT  
Sedia, poltrona e poltroncina / *Chair, lounge chair and armchair*





Keel 922/OUT - 922/P-OUT  
Sedie e poltroncina / *Chairs and armchair*





Keel 922/L-OUT, Poltrona / *Lounge chair*  
Hishi 871/TBC-OUT, Tavolino / *Coffee table*





Keel 922/A-OUT  
Sgabelli alti / *Barstools*





Keel 922/A-OUT - 922/S-OUT  
Sgabello alto e sgabello basso / *Barstool and counterstool*



# Hishi

/coffee tables

— La base in ceramica smaltata dei tavolini Hishi, disponibile nelle tonalità grigio sabbia, cioccolato e pesca, si caratterizza da un decoro a bassorilievo a maglia geometrica realizzato artigianalmente. Proposti in due diverse altezze, i tavolini sono disponibili con piano circolare o quadrato, in vetro bronzo temperato.

The glazed ceramic base of the Hishi coffee tables, available in sand grey, chocolate, and peach colors, is characterized by a handmade geometric mesh bas-relief decoration. Available in two different heights, the coffee tables are available with circular or square top, in tempered bronzed glass.



Hishi 871/TBC-OUT  
Tavolino / Coffee table





Hishi 871/TBQ-OUT - 871/TBC-OUT  
Tavolini con base in ceramica / *Coffee tables with ceramic base*





## Agra family

— Agra è una collezione declinata in sedie e poltroncine dining impilabili e sgabelli a due altezze: arredi capaci di creare ambienti dal gusto sempre nuovo grazie ad un'ampia varietà di materiali e finiture. Tratto distintivo di questa famiglia è l'intreccio a mano che conferisce alle proposte a collezione un impatto visivo di estrema leggerezza, che si adatta perfettamente a fresche atmosfere mediterranee. Ad arricchire la collezione, il tavolo Agra che si identifica per i tratti raffinati e rigorosi. Proposto con piano ovalodico in pietra naturale o hpl.

Agra is a collection declined in stackable dining chairs and armchairs and two-height stools: furnishings capable of creating environments with a new taste thanks to a wide variety of materials and finishes. A distinctive feature of this family is the hand woven seat and backrest that gives to the collection proposals a visual impact of extreme lightness, which adapts perfectly to fresh Mediterranean atmospheres. To enrich the collection, the Agra table that is identified by its refined and rigorous features. Proposed with an ovaloid top in light grey natural stone or hpl.





Agra 688/ATG-O, Tavolo / *Table*  
Agra 688/XXL - 688/PXXL, Sedie e poltroncina / *Chairs and armchair*





Agra 688/ATG-O  
Tavolo / Table







Dettaglio base / *Base detail*



Agra 688/ATG-O  
Tavolo / *Table*









Agra 688/XXL  
Sedia / *Chair*

Agra 688/PXXL  
Poltroncina / *Armchair*







Agra 688/A - 688/S  
Sgabello alto e sgabello basso / *Barstool and counterstool*





Episode

**VI.**

Approaching sunset

Tibes family / Clue rugs / Cut lounge



— Il cielo limpido del giorno cede il passo alle sfumature tenui della sera, la materia si colora dei toni caldi del tramonto. Lentamente sagome e profili si fondono con l'orizzonte trasformandosi in un corpo unico dai contorni sbiaditi, aspettando l'alba di un nuovo giorno.

The clear daylight surrenders to the soft shades of the evening, the matter is infused with the warm tones of sunset. Silhouettes and profiles slowly merge with the horizon, shaping into a single body where outlines are faded, while waiting for a new dawn.

Approaching sunset





# Tibes family

— La collezione Tibes, declinata in sedia dining e poltrona impilabili orizzontalmente e sgabelli a due altezze, è caratterizzata da un telaio leggero intrecciato a mano in corda nautica o "Gassa". La silhouette descrive traiettorie fluide e slanciate, all'insegna della leggerezza e del dinamismo. Il gioco di inclinazioni inverse delle sedie e della poltrona esprime la sua personalità unica, sottolineata dalla possibilità di essere impilate orizzontalmente.

The Tibes collection, composed of dining stackable chair and lounge chair, and two-height stools, is characterized by a light hand-woven frame in nautical rope or "Gassa" rope. The silhouette describes fluid and slender trajectories, in the name of lightness and dynamism. The play of reverse inclinations of the chairs and lounge chair expresses its unique personality, underlined by the possibility of being stacked horizontally.

Tibes 945/L  
Poltrona / *Lounge chair*









Dettaglio intreccio seduta / *Seating's weaving detail*



Tibes 945/L  
Poltrona / *Lounge chair*





Tibes 945, Sedie / *Chairs*  
Katana 026/TR4-OUT, Tavolo / *Table*













Tibes 945/A  
Sgabello alto / *Barstool*



Dettaglio intreccio seduta / *Seating's weaving detail*



Tibes 945/A, Sgabelli alti / *Barstools*  
OTX 887/TAC, Tavolo alto / *High table*





# Clue

## /rugs

— La collezione Clue nasce come trait d'union tra le sedute e i complementi d'arredo. Trecce in filato di polipropilene dai diversi contrasti, cucite tra loro con un'andatura verticale e concentrica, creano grafismi circolari inediti. Dai verdi e blu, ai classici grigi e beige, i formati rettangolari si mescolano a quelli tondi in un gioco di sagome adatte ai più diversi contesti di arredo. Versatilità e resistenza sono caratteristiche chiave della collezione. Disponibili in diverse nuance, i tappeti sono adatti alla creazione di ambienti eleganti e poliedrici.

The Clue carpets collection was born as a trait d'union between seats and furnishing accessories. Braids in polypropylene yarn with different contrasts, sewn together with a vertical and concentric gait, create unusual circular graphics. From green and blue, to classic grey and beige, rectangular sizes are mixed with round ones in a game of shapes suitable for the most diverse furnishing contexts. Versatility and resistance are key features of the collection. Available in different shades, these carpets are suitable to create elegant and multifaceted environments.





Clue 971/RBLUE - Clue 971/RPETROL - Clue 971/RBEIGE - Clue 971/R GREY, Tappeti / Carpets  
Clue 971/C GREEN - Clue 971/C GREY - Clue 971/C BEIGE, Tappeti / Carpets





Clue 971/C BEIGE - Clue 971/C GREEN  
Tappeti / Carpets





Clue 971/C GREY  
Tappeto / *Carpet*



Cluc 971/R PETROL - Cluc 971/R GREY - Cluc 971/C GREEN  
Tappeti / Carpets

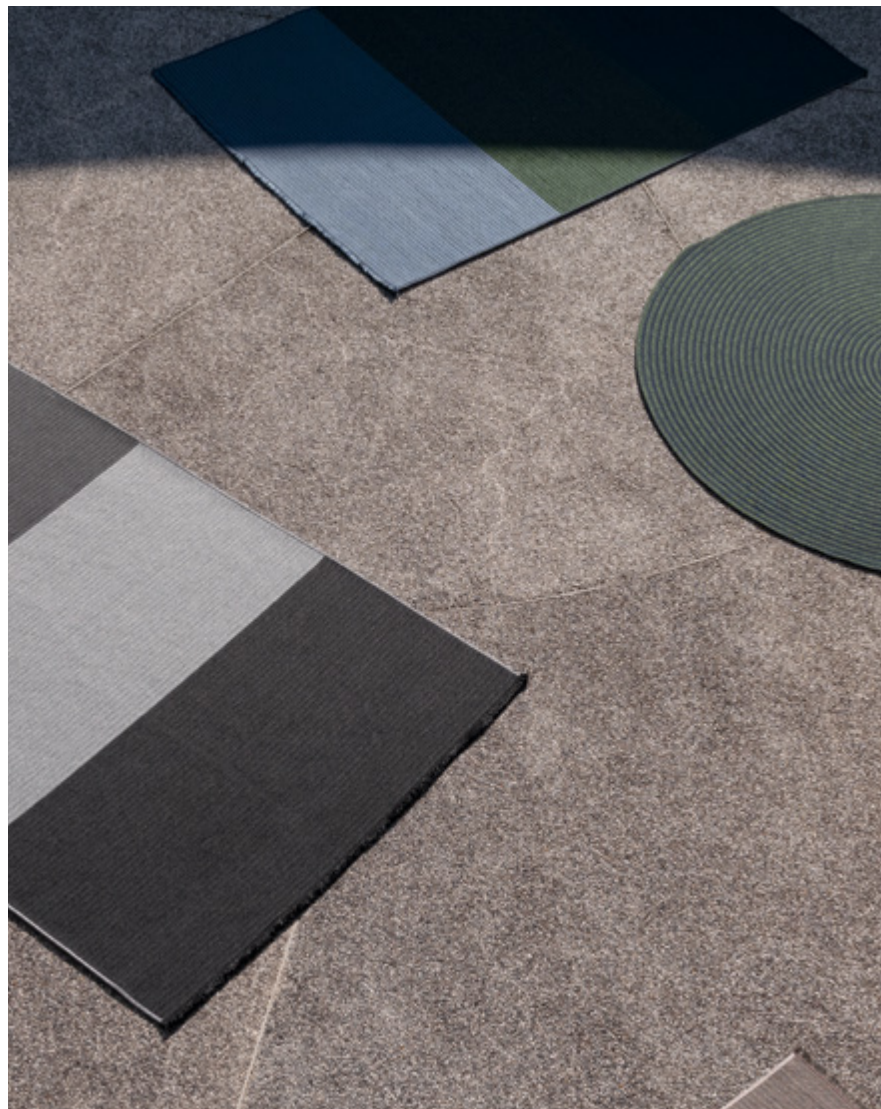

Cluc 971/R BEIGE - Cluc 971/C BEIGE  
Tappeti / Carpets





Clue 971/R BEIGE - Clue 971/R GREY  
Tappeti / Carpets





Clue 971/C GREY  
Tappeto / Carpet



Clue 971/R BLUE  
Tappeto / *Carpet*



Clue 971/R PETROL  
Tappeto / *Carpet*



# Cut

## /lounge

— Cut è una avvolgente bergère dall'aspetto leggero e confortevole, dalla struttura in tondino d'acciaio verniciato a polveri epossidiche con seduta e poggiatesta/pouf intrecciati a mano in fettuccia "Gassa" beige.

Cut is an enveloping bergère with a light and comfortable appearance, with a structure in epoxy powder coated steel rod with seat and footrest / pouf hand-woven in beige "Gassa" rope.



















Episode  
**VII.**

Dualism of nature



— Fissare il calore dei singoli attimi, lasciando che albe e tramonti si sciolgano fino a confondersi. Un'energia unica e potente che si infonde dalla terra al cielo, attraversando i pensieri nel tragitto. Un ritmo lento che sospende il tempo e fa danzare arredi dalla bellezza sussurrata fra le ore e i giorni.

Fix the heat of individual moments, letting sunrises and sunsets melt until they merge. A unique and powerful energy that infuses itself from earth to sky, crossing thoughts along the way. A slow rhythm that suspends time and makes furnishings dance with whispered beauty between hours and days.







# Loom

## /sofa system

— Ispirazione retrò per la collezione Loom composta da divano, poltrona e daybed. Minimalismo e semplicità definiscono il progetto: a disegnarne il profilo, un'essenziale cornice in massello di mogano con intreccio a mano in cordino "Gassa" o sintetico, eco di una tradizione artigianale ed espressione di una profonda abilità manuale.

Retro inspiration for the Loom collection consisting of sofa, lounge chair and daybed. Minimalism and simplicity define the project: to draw its profile, an essential frame in solid mahogany presented with hand weaving in "Gassa" or synthetic rope, echo of a traditional craftsmanship and expression of a deep manual skill.





Loom 880/PR-OUT  
Poltrona / *Lounge chair*





Loom 880/DRL-OUT+880/DRM-OUT - 880/DR-200-OUT, Divani / Sofas  
Ropu 888/TBC-OUT - 888/TBR-OUT, Tavolini / Coffee tables









Loom 880/DB-OUT  
Day bed / *Day bed*





Loom 880/DRL-OUT + 880/DRM-OUT  
Divano componibile / *Modular sofa*





## Egao family

— Famiglia di sedute composta da sedia e poltroncine dining impilabili e sgabello basso. Egao presenta una snella struttura intrecciata a mano in cordino sintetico o in corda nautica, con il quale crea una trama quadrettata che funge da seduta e schienale, e gambe in tubo Inox AISI 316 verniciato. Una famiglia di prodotti passe-partout adatta ad ogni tipo di collocazione, sia domestica che contract.

Family of seats consisting of stackable dining chair and armchairs and low stool. Egao has a slender hand-woven structure in synthetic cord or nautical rope, with which it creates a square pattern that acts as seat and backrest, and legs in painted AISI 316 stainless steel tube. A family of passe-partout products suitable for any type of location, both domestic and contract.





Egao 037/A  
Sgabelli bassi / *Counterstools*





Egao 037/P - 037 - 037/PBR  
Sedia e poltroncine / *Chair and armchairs*







# Vela family

— La famiglia Vela, composta da sedia e poltroncina dining impilabili, poltrona, sgabelli a due altezze e divano a due posti è la perfetta sintesi tra design e maestria artigianale: all'agile struttura in tubo di metallo verniciato con gambe a slitta è abbinato un intreccio realizzato a mano in cordino nautico o pvc che ne costituisce l'elemento di unicità.

The Vela family, composed of stackable dining chair and armchair, lounge chair, two-height stools and two-seater sofa is the perfect synthesis between design and craftsmanship: the agile structure in painted metal tube with sled legs is combined with a handmade weaving in nautical cord or pvc that constitutes the element of uniqueness.

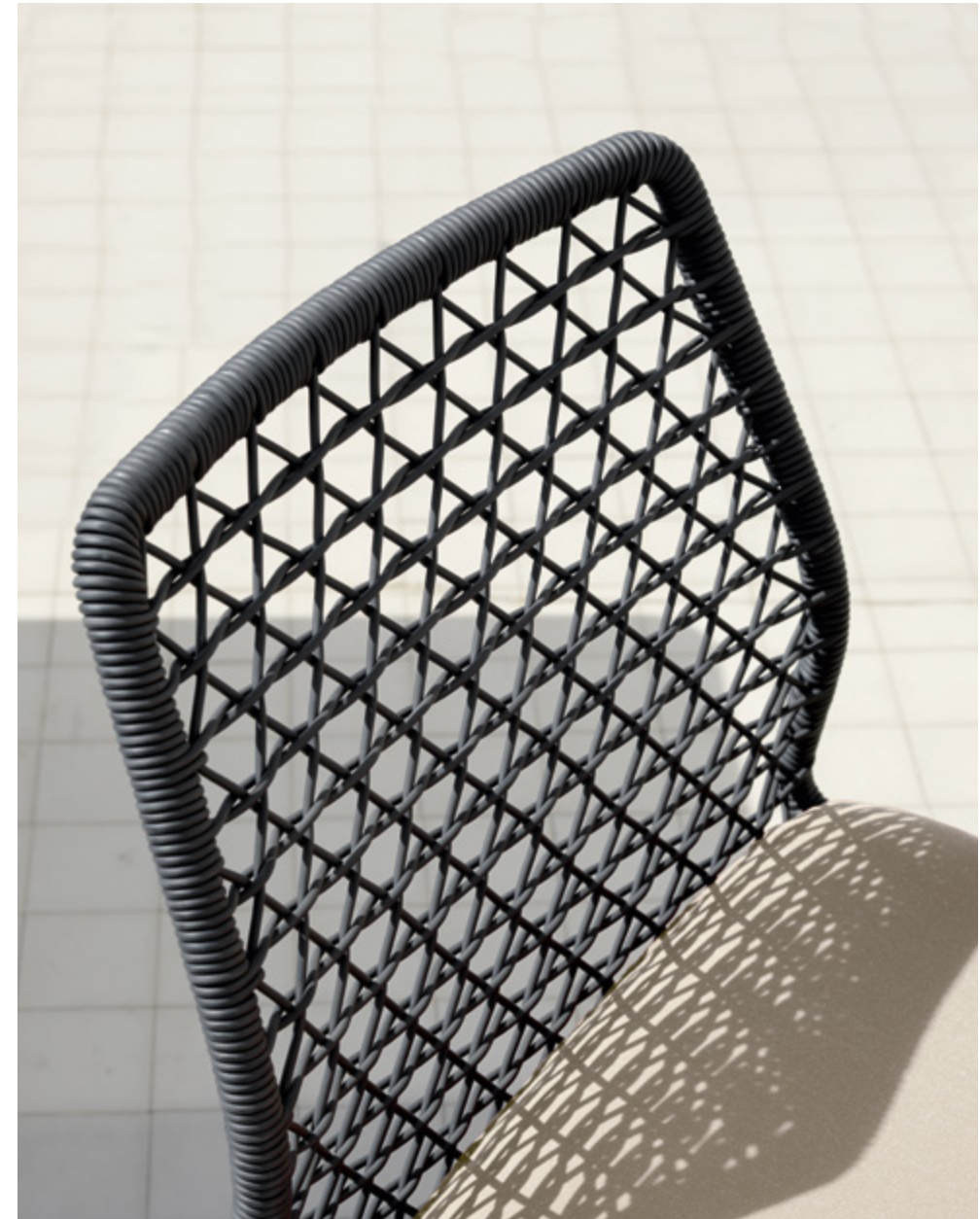

Vela 698  
Sedia / Chair









Vela 698 - 698/P  
Sedia e poltroncina / *Chair and armchair*



Dettaglio intreccio schienale / *Backrest's weaving detail*

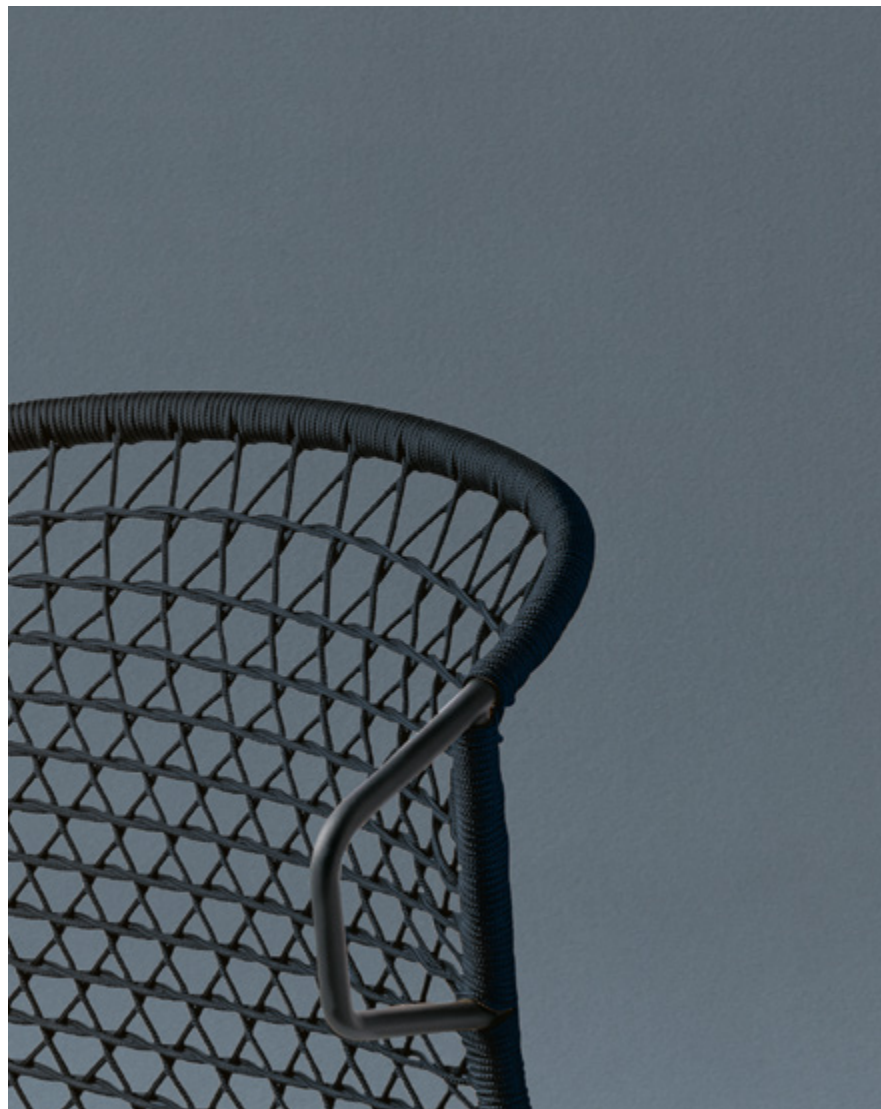

Vela 698/D  
Divano / *Sofa*









Vela 698/S, Sgabelli bassi / *Counterstools*  
OTX 887/TSC, Tavoli / *Tables*





# Velis

## /dining chair

— Declinata nella versione poltroncina pozzetto per utilizzo outdoor, con cuscino schienale incluso, Velis si presta a qualsiasi ambiente sottolineando ancora una volta la maestria artigianale dell'azienda nell'adattare i prodotti ad ogni esigenza. Velis ha una struttura in legno massello di iroko e schienale con struttura in metallo verniciato intrecciato a mano in cordino "Gassa" o corda nautica canapa.

Available in the tub chair version for outdoor use, with backrest cushion included, Velis lends itself to any environment, once again underlining the craftsmanship of the company in adapting products for every need. Velis has a solid iroko wood structure and backrest with hand-woven painted metal structure in "Gassa" rope or hemp nautical rope.



Dettaglio intreccio schienale / *Backrest's weaving detail*



Velis 942/PAR-OUT  
Poltroncina pozzetto / *Tub chair*







# Suno

## /sunbed

— Suno reinterpreta la forma universale del lettino prendisole contraddistinguendosi per le grandi ruote dal diametro 57 cm, in hpl. Un'iperbole formale che fa di un elemento funzionale il tratto estetico che connota l'intero progetto. Con struttura composta da doghe in massello di iroko e corredata da un materasso imbottito, Suno presenta uno schienale regolabile in diverse inclinazioni per vivere il relax all'aria aperta all'insegna del massimo comfort.

Suno reinterprets the universal shape of the sunbed, distinguishing itself for the large wheels with a diameter of 57 cm, in hpl. A formal hyperbole that makes of a functional element the aesthetic trait that characterizes the entire project. With a structure composed of solid iroko wood slats and accompanied by a padded mattress, Suno has a backrest adjustable in three different inclinations to enjoy relaxation in the open air in the name of maximum comfort.













Technical  
sheet.



## COPERTURE OUTDOOR \ OUTDOOR COVERINGS

Per tutti i nostri prodotti outdoor sono disponibili coperture impermeabili per lo stoccaggio durante il periodo di non utilizzo.  
Per ulteriori specifiche e dettagli fare riferimento al listino prezzi.

For all our outdoor products waterproof covers are available for stocking during the period of non-use.  
For further specifications and details refer to the price list.

### AGRA

Design Enrico Franzolini

pag. 74-75, 133, 135, 188, 190-191, 192-193, 195, 196, 197, 199, 200, 201, 202-203

Sedia e poltroncina dining impilabili e sgabelli con struttura in tubo d'acciaio verniciato goffrato bianco o antracite. Disponibile con intrecci in cordino sintetico moka o in pvc antracite o bianco opaco.

Tavolo con abbinamenti predefiniti a collezione:

- Base in acciaio verniciato bianco goffrato e piano in hpl bianco o pietra naturale.
- Base in acciaio verniciato antracite goffrato e piano in hpl antracite, pietra naturale o grès porcellanato ossido nero.

Stackable dining chair and armchair, and stools with structure in white or anthracite embossed painted steel tube. Available with weaving in moka synthetic or anthracite or matt white pvc ropes.

Predefined table combinations as per collection:

- Embossed white painted steel base with white hpl or light grey natural stone top.
- Embossed anthracite painted steel base with anthracite hpl, light grey natural stone or black oxide laminated porcelain top.

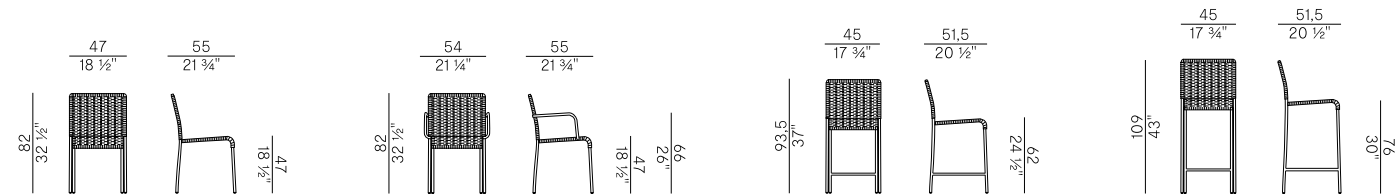

**688/XXL** x6  
sedia impilabile \ stackable chair

**688/PXXL** x4  
poltroncina impilabile \ stackable armchair

**688/S**  
sgabello basso \ counterstool

**688/A**  
sgabello alto \ barstool

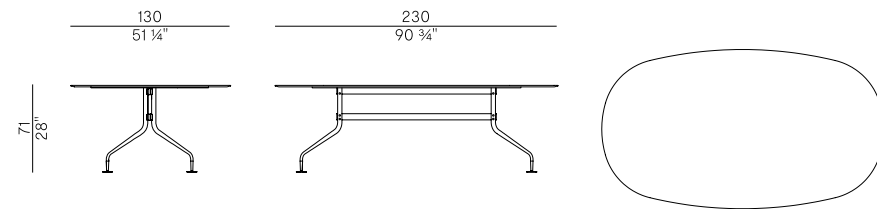

**688/ATG-O**  
tavolo \ table

### ALYZA

Design Mario Ferrarini

pag. 109, 110, 111, 112, 113, 142, 147, 148-149

Sedia e poltroncina dining con struttura in tondino d'acciaio verniciato a polveri epossidiche per outdoor. Cuscino seduta in poliuretano integrale autopellante.

Combinazioni:

- Acciaio verniciato antracite goffrato e seduta in poliuretano antracite.
- Acciaio verniciato bianco goffrato e seduta in poliuretano grigio chiaro.

Dining chair and armchair with embossed steel rod painted with epoxy powders for outdoor use. Seat cushion in tear-resistant outer skin and soft inner structure.

Combinazioni:

- Embossed anthracite painted steel and anthracite polyurethane seat.
- Embossed white painted steel and light grey polyurethane seat.

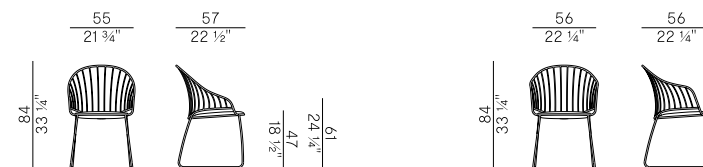

**948**  
sedia \ chair

**948/P**  
poltroncina \ armchair

### BUTLER

Design Bernhardt & Vella

pag. 105, 106, 292-293

Carrello con struttura in tubo d'acciaio verniciato a polveri epossidiche per outdoor finitura antracite goffrato e piano in legno massello di iroko. Cassetto contenitore fisso e porta bottiglie laterale removibile in lamiera di acciaio verniciato antracite goffrato. Ruote in hpl antracite con protezione in gomma.

Trolley with structure in embossed anthracite steel tube painted with epoxy powders for outdoor use and solid iroko wood top. Fixed drawer container and removable side bottle holder in anthracite embossed lacquered painted steel. Anthracite hpl wheels with rubber protection.

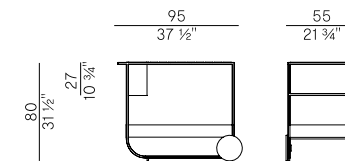

**892**

carrello \ trolley

### CLUE

Design Chiara Andreotti

pag. 100-101, 102, 103, 120-121, 122, 133, 135, 154, 155, 160, 163, 199, 224, 226-227, 228, 229, 230, 232, 233, 234, 235, 236-237, 238, 239

Collezione di tappeti outdoor rettangolari in due dimensioni, e circolari in un'unica dimensione, realizzati con treccia in filato di polipropilene intelaiato a mano. Tinti in massa con speciale protettore UV e antiossidanti. Le combinazioni dei colori sono predefinite e fisse:

Collection of rectangular outdoor carpets in two sizes, and circular in one size, made of hand-framed polypropylene yarn. Dyed with special UV protector and antioxidants. The color combinations are predefined and fixed:

Tappeti rettangolari:

- Marrone - tortora - beige
- Grigio perla - blu - carta da zucchero
- Grigio - grigio perla - grigio antracite
- Carta da zucchero - verde bosco - petrolio

Rectangular carpets:

- Marrone - tortora - beige
- Grigio perla - blu - carta da zucchero
- Grigio - grigio perla - grigio antracite
- Carta da zucchero - verde bosco - petrolio

Tappeti circolari:

- Beige - tortora
- Verde bosco - blu
- Grigio - grigio perla

Circular carpets:

- Beige - tortora
- Verde bosco - blue
- Grigio - grigio perla

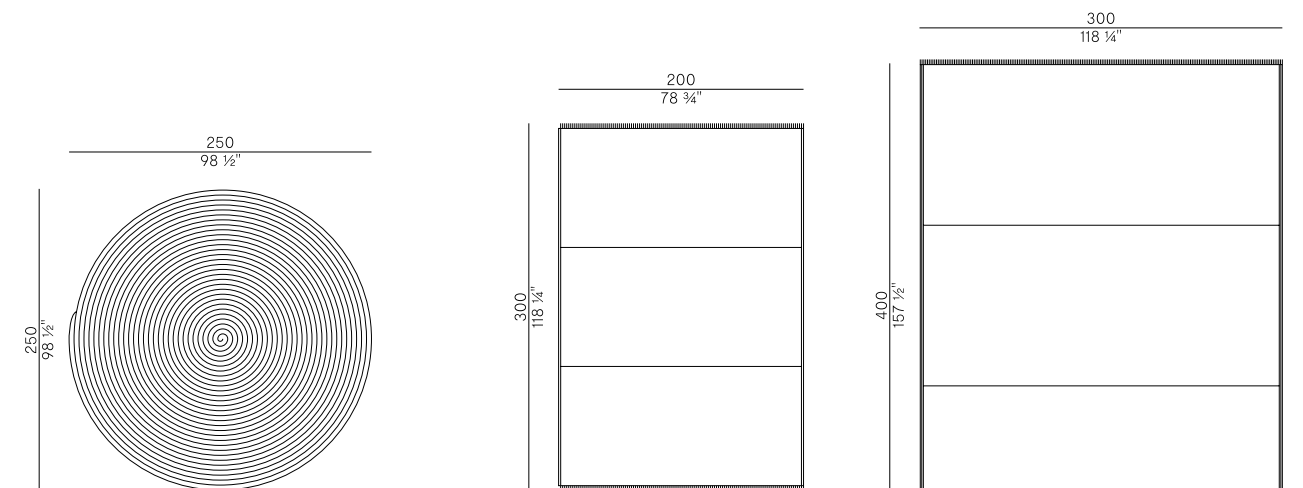

**971/C**

tappeto \ carpet

**971/R**

tappeto \ carpet



## CUT

Design Stephan Veit  
pag. 241, 242-243, 245, 246-247

Bergère con struttura in tondino d'acciaio verniciato a polveri epossidiche per outdoor nelle finiture Aval o bianco goffrato. Seduta e poggiatesta intrecciati a mano in fettuccia "Gassa" beige. Cuscino seduta, poggiatesta e cuscino poggiatesta, removibili e sfoderabili, imbottiti in poliuretano espanso ignifugo con rivestimento sigillante. Rivestimenti di collezione.

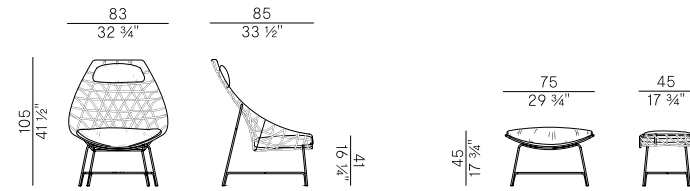

910/PLR  
bergère \ bergère

910/PPR  
pouf \ pouf

Bergère with epoxy powder coated steel rod frame for outdoor use in embossed Aval or white finishes. Hand-woven seat and footrest/pouf in beige "Gassa" rope. Seat cushion, headrest, and footrest cushion, removable and detachable, padded with fire retardant polyurethane foam with sealing coating. Coverings as per collection.

## DOUBLE L

Design Chiara Andreotti  
pag. 28, 30-31, 32, 34-35, 38, 42, 46-47, 49, 50, 52, 53, 210-211

Tavolino con piano circolare e base in lamiera d'acciaio verniciata a polveri epossidiche per outdoor finitura nero goffrato. Raccordo tra le basi in tubo di acciaio verniciato nero goffrato e piano in grès porcellanato ossido nero o pietra naturale.

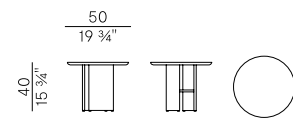

952/TC-OUT  
tavolino \ coffee table

Coffee table with circular top and base in epoxy powder coated steel sheet for outdoor use with black embossed finish. Connection between the bases in embossed painted black steel and top in black oxide laminated porcelain or light grey natural stone.

## EGAO

Design Toan Nguyen  
pag. 54, 59, 264, 267, 268-269, 270-271

Sedia e poltroncine dining impilabili e sgabello basso. Struttura con gambe in tubo d'acciaio inox AISI 316 verniciato antracite o bianco goffrato. Struttura intrecciata a mano in cordino sintetico moka o corda nautica canapa, antracite o blu navy. Poltroncina disponibile in due versioni: braccioli con o senza intreccio.

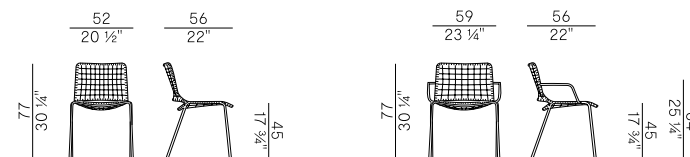

037  
sedia impilabile \ stackable chair

037/P  
poltroncina impilabile \ stackable armchair

Stackable dining chair and armchairs and counterstool. Structure with legs in AISI 316 stainless steel tube, painted in anthracite, or white embossed finishes. Hand-woven in moka synthetic rope or hemp, anthracite, or blue navy nautical rope. Armchair available in two versions: armrests with or without interweaving.

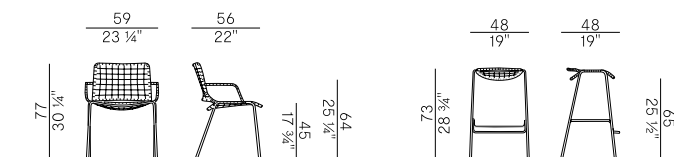

037/PBR  
poltroncina impilabile braccioli intrecciati \ stackable armchair woven armrests

037/A  
sgabello basso \ counterstool

## ELODIE

Design Chiara Andreotti  
pag. 98, 100-101, 102, 103

Divano a due posti e poltrona con struttura in lamiera e tubo d'acciaio verniciato goffrato antracite, bianco o Aval. Imbottitura in poliuretano espanso ignifugo con rivestimento sigillante. Cuscini dello schienale e della seduta sfoderabili e staccabili dalla struttura. I cuscini dello schienale sono fissati con zip al sedile. I cuscini laterali sono su richiesta. Rivestimenti di collezione.

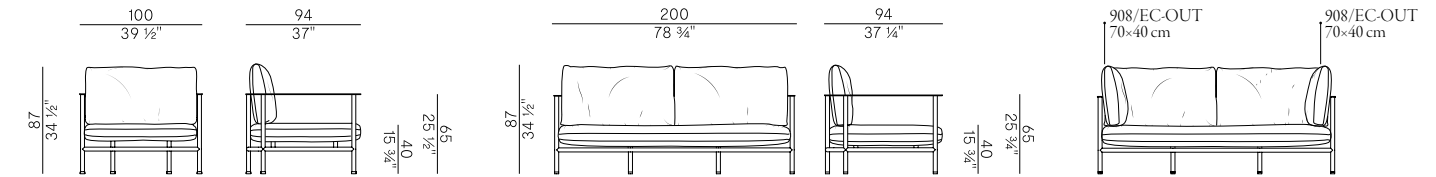

908/PL-OUT  
poltrona \ lounge chair

908/D-OUT  
divano \ sofa

908/EC-OUT  
70x40 cm  
908/EC-OUT  
70x40 cm  
cuscini laterali opzionali \ optional side cushions

Two-seater sofa and lounge chair with structure in anthracite, white or Aval embossed painted steel tube. Padding in fire retardant polyurethane foam with sealing coating. Back and seat cushions removable and detachable. The back cushions are zippered to the seat. Side cushions on request. Coverings as per collection.

## HERM

Design Gianluigi Landoni  
pag. 128, 130-131

Famiglia di pouf imbottiti in poliuretano espanso ignifugo con rivestimento sigillante. Disponibili in tre misure. Fascia con cucitura a vista. Rivestimenti di collezione.

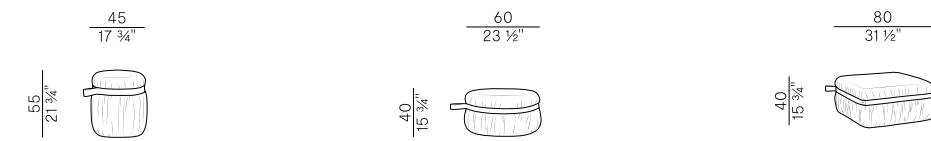

925/O45-OUT  
pouf \ pouf

925/O60-OUT  
pouf \ pouf

925/O80-OUT  
pouf \ pouf

Family of upholstered poufs in fire retardant polyurethane foam with sealing coating. Available in three sizes. Belt with visible stitching. Coverings as per collection.

## HISHI

Design Chiara Andreotti  
pag. 179, 185, 186-187

Collezione di tavolini con piano circolare o quadrato, in vetro bronzo temperato e base in ceramica smaltata, altezza 47 cm o 55 cm, con finitura lucida color pesca, grigio sabbia o cioccolato. Borchia alla base del piano con finitura ottone brunito.

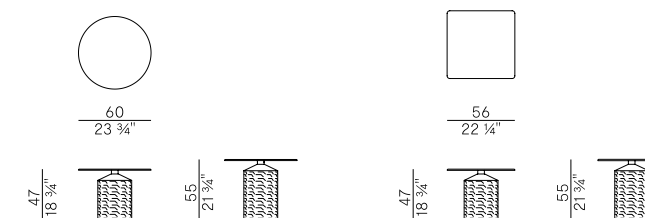

871/TBC-OUT  
tavolino \ coffee table

871/TBQ-OUT  
tavolino \ coffee table

Collection of coffee tables with circular or square top, in tempered bronzed glass and glazed ceramic base, height 47 cm or 55 cm, with glossy peach, sand grey or chocolate finishes. Stud at the base of the top with bronzed brass finish.



## KATANA

Design Mauro Lipparini

pag. 71, 72, 142, 144-145, 147, 148-149, 216-217

Famiglia di tavoli con gambe in lamiera d'acciaio verniciato antracite o Aval goffrato. Tavolo circolare con tre gambe, tavolo rettangolare con quattro gambe. Piani in hpl antracite o grès porcellanato ossido nero. Finiture di collezione.

Family of tables with legs in anthracite or Aval embossed painted steel. Circular table with three legs, rectangular table with four legs. Top in black oxide laminated porcelain or hpl. Finishes as per collection.

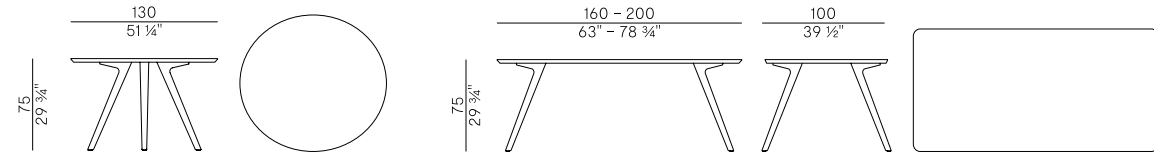

026/TC3-OUT

tavolo \ table

026/TR4-OUT

tavolo \ table

## KEEL

Design M+V

pag. 130, 171, 172, 174-175, 176-177, 178, 179, 180, 182-183

Collezione costituita da sedia e poltroncina dining, poltrona e sgabelli a due altezze. Struttura in tondino d'acciaio verniciato a polveri epossidiche per outdoor nelle finiture antracite, Aval e bianco perla, schienale in massello di iroko. Seduta imbottita in poliuretano espanso ignifugo. Rivestimenti di collezione.

Collection consisting of dining chair and armchair, lounge chair and stools in two heights. Structure in anthracite, Aval or pearl white embossed steel rod for outdoor, backrest in solid iroko wood. Upholstered seat in fire retardant polyurethane foam. Coverings as per collection.

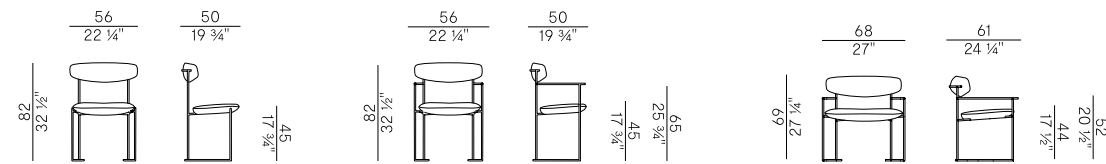

922-OUT

sedia \ chair

922/P-OUT

poltroncina \ armchair

922/L-OUT

poltrona \ lounge chair

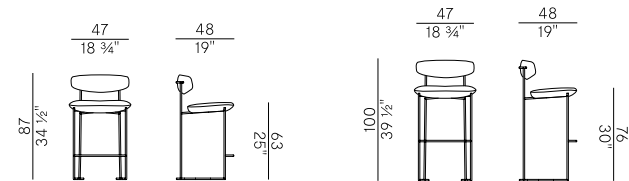

922/S-OUT

sgabello basso \ counterstool

922/A-OUT

sgabello alto \ barstool

## KEEL LIGHT

Design M+V

pag. 138, 160, 163, 164, 166-167, 168

Collezione costituita da sedia e poltroncina dining, poltrona e sgabelli a due altezze. Struttura in tondino d'acciaio verniciato a polveri epossidiche per outdoor nelle finiture antracite, Aval e bianco perla. Schienale in massello di iroko. Seduta imbottita con guscio sottostante rigido verniciato acrilico per esterno, nello stesso colore e goffatura fine del fusto. Rivestimenti di collezione.

Collection consisting of dining chair and armchair, lounge chair and stools in two heights. Structure in embossed metal rod painted with epoxy powders in anthracite, Aval and pearl white finishes. Backrest in solid iroko wood. Padded seat with rigid underlying shell, acrylic painted for outdoors, in the same color and fine embossing of the structure. Coverings as per collection.

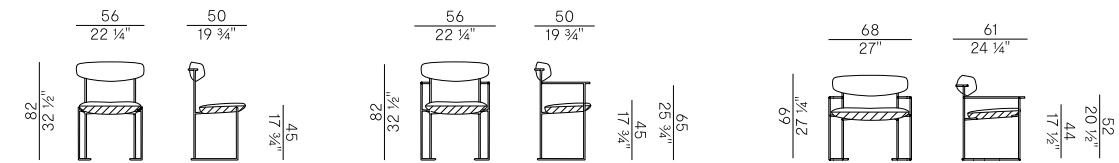

922/MB-OUT

sedia \ chair

922/PMB-OUT

poltroncina \ armchair

922/LMB-OUT

poltrona \ lounge chair

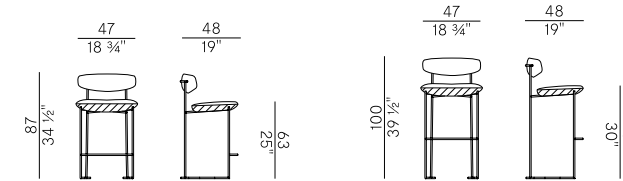

922/SMB-OUT

sgabello basso \ counterstool

922/AMB-OUT

sgabello alto \ barstool

## LITTLE T

Design Potocco D&D

pag. 66-67, 100-101, 120-121, 150, 152-153, 154, 155, 252

Famiglia di tavolini con piano rettangolare o quadrato in tre dimensioni e due altezze. Struttura in lamiera e tubo d'acciaio verniciato antracite goffrato. Piano in grès porcellanato ossido nero o pietra naturale.

Family of coffee tables with rectangular or square top in three sizes and two heights. Anthracite embossed lacquered steel tube frame and top in black oxide laminated porcelain or light grey natural stone.



878/TQ-50-OUT

tavolino \ coffee table

878/TQ-100-OUT

tavolino \ coffee table

878/TR-OUT

tavolino \ coffee table



## LOOM

Design David Lopez Quincoces  
pag. 252, 255, 256-257, 258-259, 260, 262-263

Collezione di divani componibili, poltrona e daybed. Struttura in tubo d'acciaio e gambe in acciaio inox AISI 316 tutto verniciato a polveri epossidiche per outdoor finitura antracite goffrato. La struttura dello schienale e dei braccioli è in massello di mogano tinto noce e l'intreccio in cordino "Gassa" beige o cordino sintetico moka. Cuscinatura interna in poliuretano espanso ignifugo con rivestimento sigillante. Cuscini seduta sfoderabili e removibili. Cuscini laterali su richiesta. Rivestimenti di collezione.

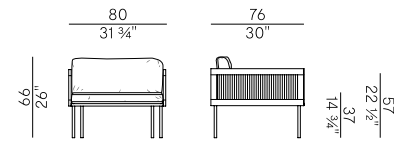

880/PR-OUT  
poltrona \ lounge chair

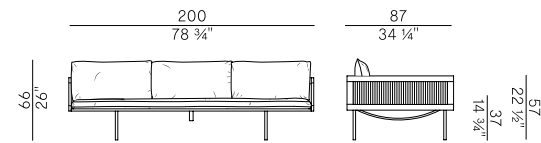

880/DR-200-OUT  
divano \ sofa

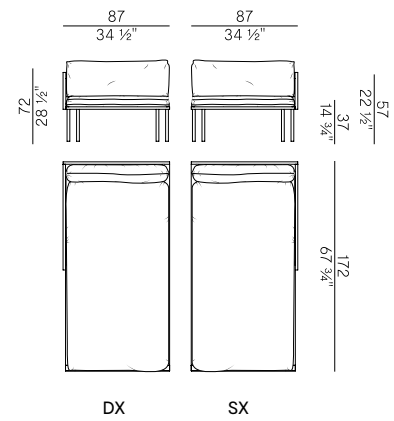

880/DRL-OUT  
modulo chaise longue destro e sinistro \ right and left chaise longue unit

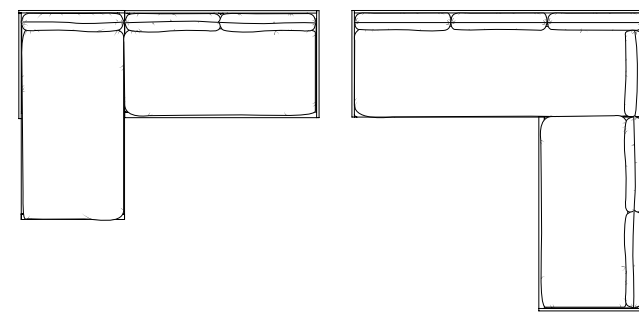

880/DRL-OUT+DRM-OUT  
divano componibile \ modular sofa

880/DR-OUT+DRM-OUT  
divano componibile \ modular sofa

Collection of modular sofas, lounge chair and daybed. Structure in steel tube and legs in AISI 316 stainless steel all painted with embossed anthracite lacquered epoxy powders for outdoor. The structure of the backrest and armrests is in solid walnut-stained mahogany and the weaving is in beige "Gassa" rope or synthetic moka rope. Internal cushions in fire retardant polyurethane foam with sealing coating. Seat cushions removable and detachable. Side cushions on request. Coverings as per collection.

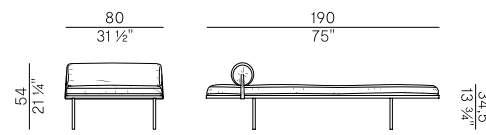

880/DB-OUT  
daybed \ daybed

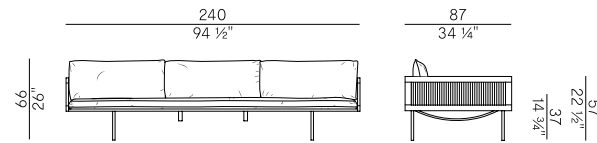

880/DR-OUT  
divano \ sofa

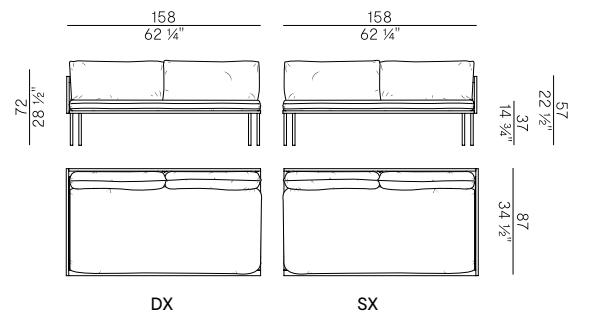

880/DRM-OUT  
modulo laterale destro e sinistro \ right and left side unit

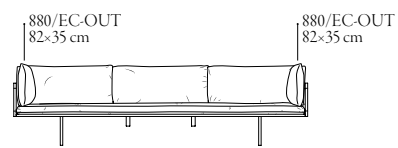

cuscini laterali \ side cushions

## OLA

Design Radice & Orlandini  
pag. 57, 64, 66-67, 68, 69, 70, 71, 72, 73, 74-75, 76, 79, 80, 82, 83, 84-85, 86-87

Famiglia di sedute così composta:

- Sedia e poltroncina dining impilabili
- Poltroncina dining
- Poltroncina pozzetto
- Poltrona e divano a due posti
- Sgabelli impilabili a due altezze.

Struttura in tondino d'acciaio verniciato a polveri epossidiche per esterno intrecciata a mano in fettuccia "Fly". Gambe in tubo di acciaio inox AISI 316 verniciate nella finitura goffrata antracite o Aval. Cuscino seduta imbottito in poliuretano espanso ignifugo con rivestimento sigillante e ovatta poliestere removibile e sfoderabile. Fodera finale nei tessuti outdoor a collezione con fondo in rete traspirante. Rivestimenti di collezione.

Seating family composed as follows:

- Stackable dining chair and armchair
- Dining armchair
- Tub chair
- Two-seater sofa and lounge chair
- Stackable stools in two heights.

Structure made of lacquered steel with outdoor epoxy powders, hand woven in "Fly" ribbon. Legs in AISI 316 stainless steel tube painted in anthracite or Aval embossed finish. Seat cushion padded with fire retardant polyurethane foam with sealing coating and removable and detachable polyester wadding. Final lining in outdoor fabrics as per collection with breathable mesh bottom. Coverings as per collection.

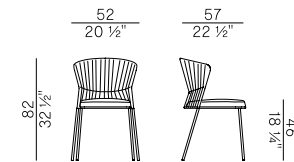

923  
sedia impilabile \ stackable chair  
☞ x4 con cuscino \ with cushion  
☞ x6 senza cuscino \ without cushion

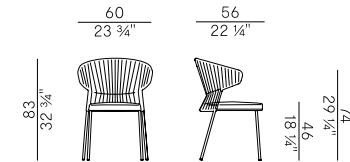

923/P-IMP  
poltroncina impilabile \ stackable armchair  
☞ x4 con cuscino \ with cushion  
☞ x6 senza cuscino \ without cushion

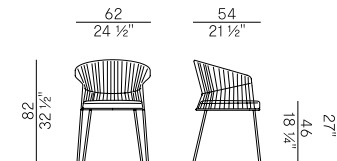

923/P  
poltroncina \ armchair

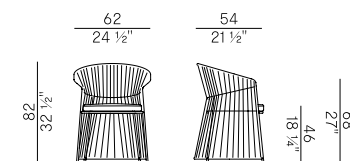

923/PMF  
poltroncina pozzetto \ tub chair

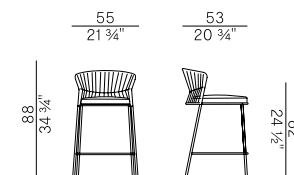

923/S  
sgabello basso impilabile \ stackable counterstool  
☞ x4 con cuscino \ with cushion  
☞ x6 senza cuscino \ without cushion

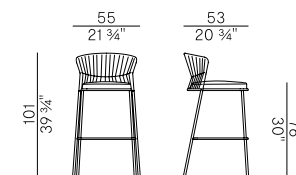

923/A  
sgabello alto impilabile \ stackable barstool  
☞ x4 con cuscino \ with cushion  
☞ x6 senza cuscino \ without cushion

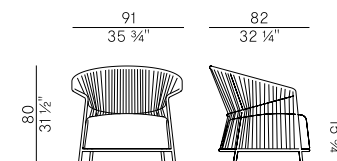

923/PL  
poltrona \ lounge chair

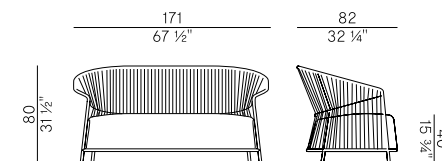

923/D  
divano \ sofa



## OTX

Design Gabriele e Oscar Buratti

pag. 84-85, 112, 113, 133, 135, 136-137, 138, 140-141, 164, 223, 270-271, 283, 284, 288

Famiglia di tavoli così composta:

- Tavoli da bar impilabili con base a 4 razze in tubo d'acciaio verniciato, con piano reclinabile, circolare o quadrato, disponibili in tre altezze e tre dimensioni. Base nelle finiture goffrate antracite, Aval o bianco e top in hpl bianco o antracite. Piedini regolabili.
- Tavolo da pranzo con piano circolare disponibile in due dimensioni. Base nelle finiture goffrate antracite, Aval o bianco e top in hpl bianco o antracite. Piedini regolabili.

Family of tables composed as follows:

- Stackable bar tables with 4-star base in painted steel tube, with reclining top, circular or square, available in three heights and three sizes. Base in anthracite, Aval, or white embossed finishes and top in white or anthracite hpl. Adjustable feet.
- Dining table with circular top available in two sizes. Base in anthracite, Aval, or white embossed finishes and top in white or anthracite hpl. Adjustable feet.

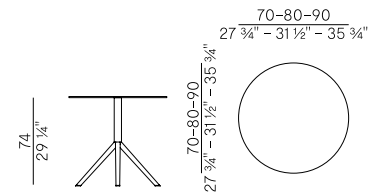

887/TC

tavolo pieghevole e impilabile \ folding and stackable table

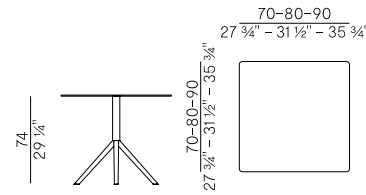

887/TQ

tavolo pieghevole e impilabile \ folding and stackable table

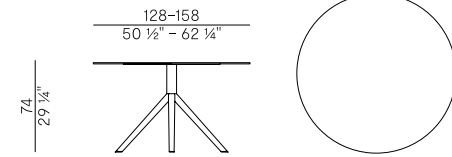

887/TGC

tavolo dining \ dining table

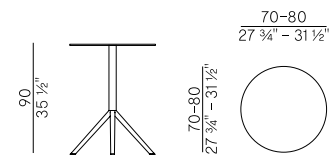

887/TSC

tavolo pieghevole e impilabile \ folding and stackable table

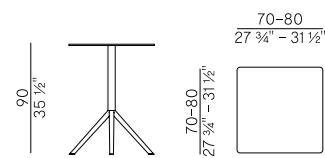

887/TSQ

tavolo pieghevole e impilabile \ folding and stackable table

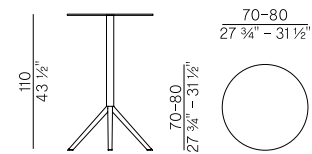

887/TAC

tavolo pieghevole e impilabile \ folding and stackable table

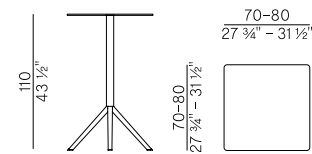

887/TAQ

tavolo pieghevole e impilabile \ folding and stackable table

## ROPU

Design Chiara Andreotti

pag. 118, 120-121, 122, 123, 124-125, 127, 163, 256-257

Collezione di tavolini e pouf con struttura in tubo e tondino d'acciaio verniciato antracite goffrato e cornice intrecciata a mano in cordino "Gassa" testa di moro. La collezione è così composta:

- Tavolino con top rettangolare in grès porcellanato ossido nero o hpl antracite.
- Tavolino con top circolare in grès porcellanato ossido nero o hpl antracite.
- Pouf rettangolare con cuscino sfoderabile imbottito in poliuretano espanso ignifugo con rivestimento sigillante, removibile e sfoderabile.

Rivestimenti di collezione.

Collection of coffee tables and pouf with structure in embossed anthracite painted steel rod and hand-woven frame in "Gassa" dark brown rope. The collection is composed as follows:

- Coffee table with rectangular top in black oxide laminated porcelain or anthracite hpl.
- Coffee table with circular top in black oxide laminated porcelain or anthracite hpl.
- Rectangular pouf with removable cushion padded with fire retardant polyurethane foam with sealant cover, removable and detachable.

Coverings as per collection.

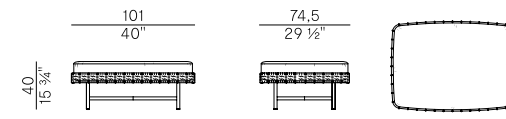

888/CQR-OUT

pouf \ pouf

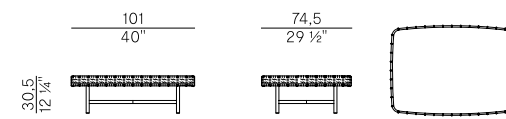

888/TBR-OUT

tavolino \ coffee table

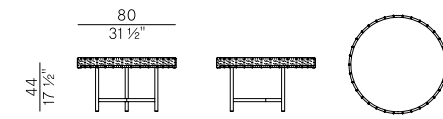

888/TBC-OUT

tavolino \ coffee table

## SOPHIE

Design Chiara Andreotti

pag. 54, 56, 57, 59, 166-167

Tavolo con piano circolare in due dimensioni. Base in lamiera e tubo d'acciaio verniciato a polveri epossidiche rivestita e intrecciata a mano in corda nautica canapa o "Gassa" testa di moro. Piano Ø160 in legno frassino waterproof con doghe assemblate con tiranti interni in acciaio inox. Piano Ø140 in pietra naturale.

Table with circular top, in two dimensions. Epoxy powder coated steel base covered in hemp nautical rope or dark brown "Gassa" rope. Top in waterproof ash wood, Ø160, with slats assembled with internal stainless-steel rods. Top in light grey natural stone Ø140.

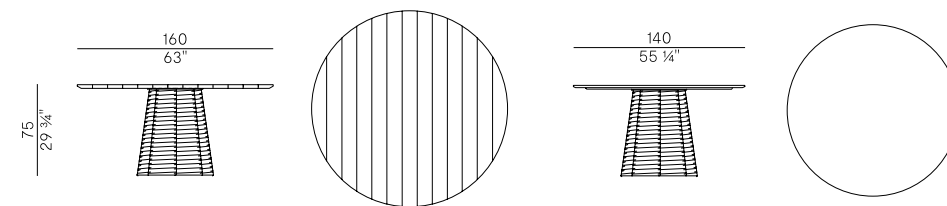

951/T

tavolo \ table



**SOUL**

Design Gabriele e Oscar Buratti  
pag. 28, 30-31, 32, 33, 34-35, 36-37, 38, 40, 41, 42, 45, 46-47

Collezione composta da divano componibile, poltrona, chaise longue, pouf e tavolini.  
Divano, poltrona, chaise longue e pouf con struttura in lamiera e tubo d'acciaio verniciato a polveri epossidiche per outdoor, finitura antracite goffrato.  
Gambe in tubo d'acciaio inox AISI 316 verniciato a polveri epossidiche per outdoor.  
Schienale intrecciato a mano in treccia imbottita antracite. Imbottitura in poliuretano espanso ignifugo con rivestimento sigillante. I cuscini dello schienale e della seduta sono sfoderabili e staccabili dalla struttura. Rivestimenti di collezione.  
Tavolini in due dimensioni con base in lamiera e tubo d'acciaio verniciato a polveri epossidiche per outdoor antracite goffrato e piano in legno frassino waterproof, grès porcellanato ossido nero o pietra naturale.

Collection composed of modular sofa, lounge chair, chaise longue, pouf, and coffee tables.  
Sofa, lounge chair, chaise longue, and pouf with structure in epoxy powder coated embossed anthracite steel tube for outdoor. Feet in AISI 316 stainless steel tube painted with epoxy powders for outdoor. Hand-woven backrest in anthracite padded braid. Padding in fire retardant polyurethane foam with sealing coating. The back and seat cushions are removable and detachable from the structure. Coverings as per collection.  
Coffee tables in two sizes with base in epoxy powder coated embossed anthracite steel tube for outdoor and top in waterproof ash, black oxide laminated porcelain or light grey natural stone.

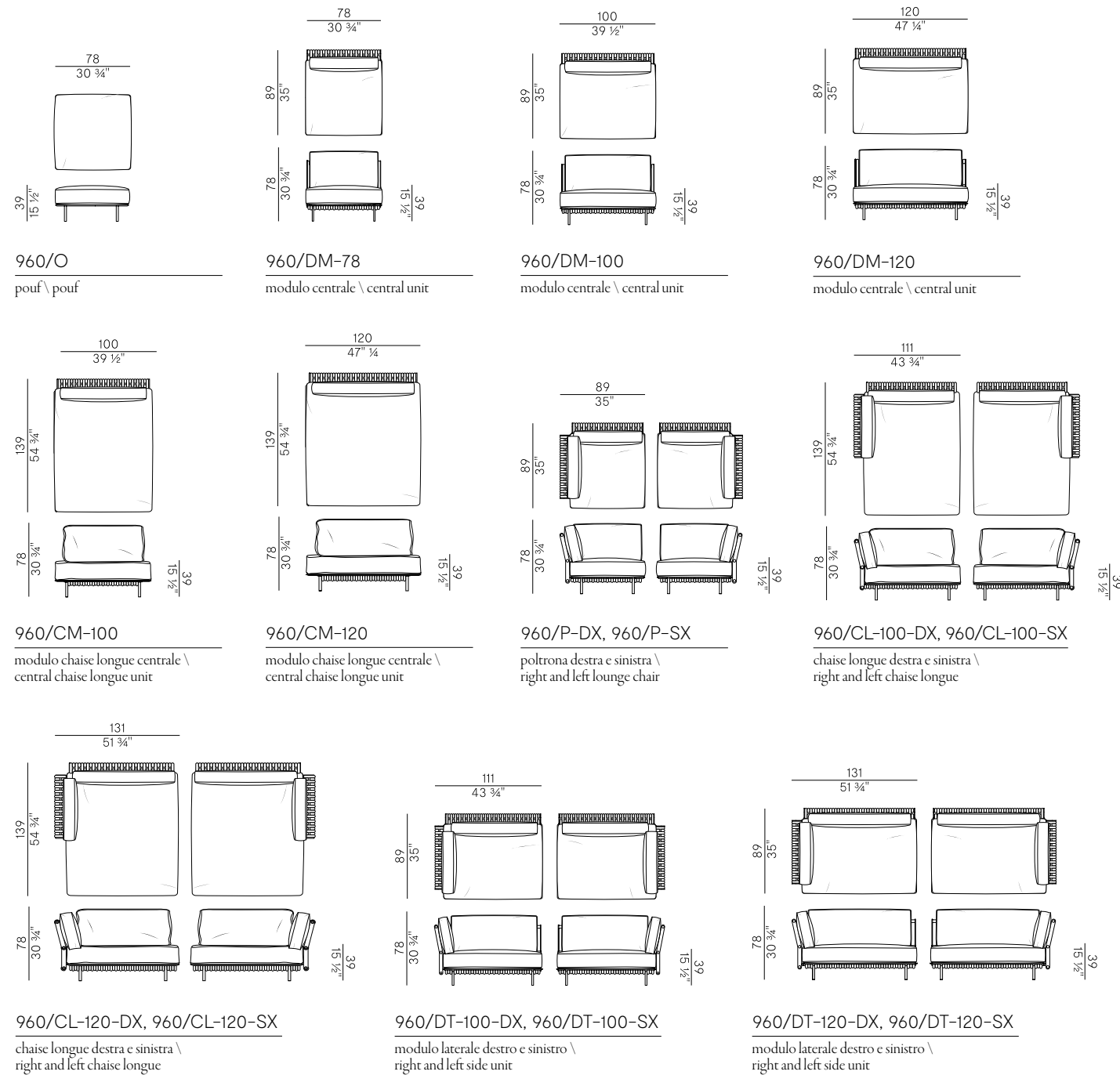

ESEMPI DI COMPOSIZIONE \ COMPOSITION EXAMPLES

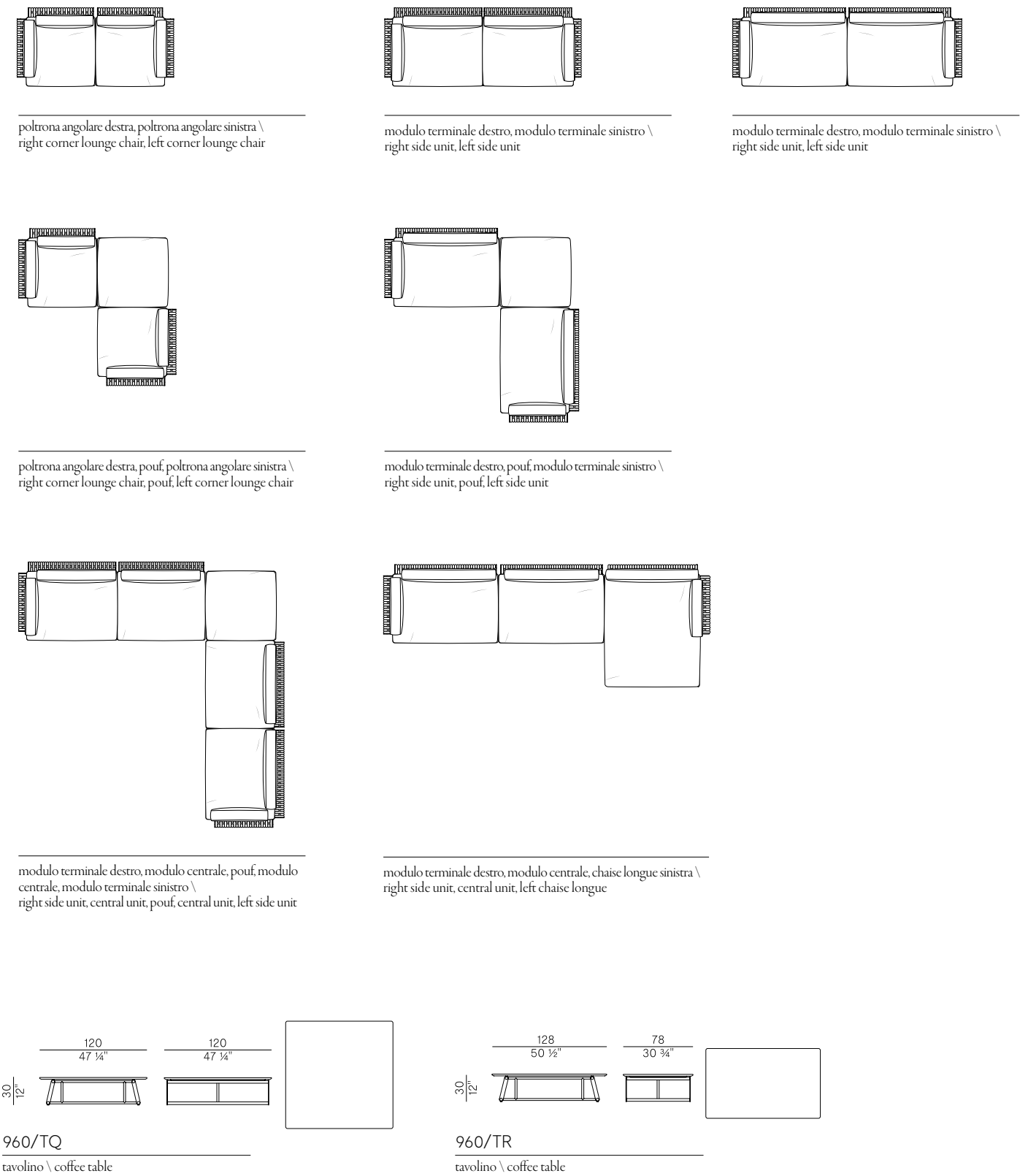



## SUNO

Design Johan Lindstén  
pag. 291, 292-293, 294-295

Letto con schienale reclinabile in tre posizioni, struttura e doghe in legno massello di iroko e ruote in hpl antracite con protezione in gomma. Cuscino opzionale imbottito in DryFeel. Rivestimenti di collezione.

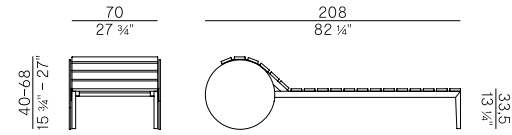

895/D-RECL

lettino \ sunbed

Sunbed with reclining backrest in three positions, structure, and slats in solid iroko wood and wheels in anthracite hpl with rubber protection. Optional cushion padded in DryFeel. Coverings as per collection.

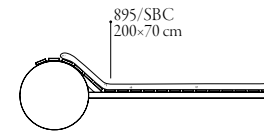

cuscino \ cushion

## TIBES

Design Gregorio Facco  
pag. 50, 208, 210-211, 212, 213, 214, 216-217, 218, 219, 220, 222, 223

Famiglia di sedute composta da sedia dining, poltrona e sgabelli in due altezze. Struttura in tubo d'acciaio verniciato o tubo verniciato a polveri epossidiche per outdoor di acciaio finitura antracite o bianco goffrato e seduta e schienali intrecciati a mano.

Abbinamenti predefiniti a collezione:

- Fusto verniciato bianco goffrato e corda nautica canapa.
- Fusto verniciato antracite goffrato e cordino "Gassa" testa di moro.

Impilabili orizzontalmente.

Seating family consisting of dining chair, lounge chair and stools in two heights.

Structure in painted steel tube or epoxy powder coated steel tube for outdoor in embossed anthracite or white finishes, and hand-woven seat and backrests.

Predefined combinations as per collection:

- Embossed white painted structure and hemp nautical rope.
- Embossed anthracite painted structure and dark brown "Gassa" rope.

Stackable horizontally.

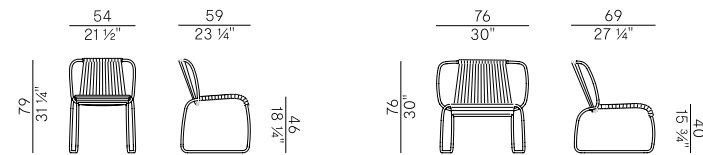

945

sedia \ chair

✎ x4

945/L

poltrona \ lounge chair

✎ x4

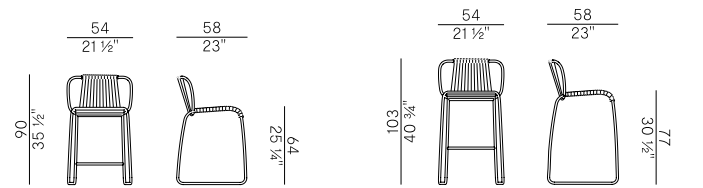

945/S

sgabello basso \ counterstool

✎ x4

945/A

sgabello alto \ barstool

✎ x4

## VELA

Design Hannes Wettstein  
pag. 273, 274-275, 276-277, 278, 279, 280, 283

Famiglia di sedute composta da sedia e poltroncina dining impilabili, poltrona impilabile, sgabelli a due altezze e divano a due posti. Struttura in tubo di acciaio verniciato seduta e schienale in cordino intrecciati a mano.

Abbinamenti predefiniti a collezione:

- Struttura verniciata bianco goffrato e cordino pvc bianco opaco;
- Struttura verniciata antracite goffrato e cordino pvc antracite opaco o corda nautica canapa.

Disponibile cuscino di seduta.

Seating family consisting of stackable dining chair and armchair, stackable lounge chair, two-height stools, and two-seater sofa. Structure in painted steel tube, seat, and backrest in hand-woven rope.

Predefined combinations as per collection:

- Embossed white painted structure and matt white pvc rope.
- Embossed anthracite painted structure and matt anthracite pvc rope or hemp nautical rope.

Seat cushion available.

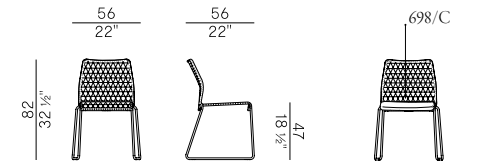

698

sedia impilabile \ stackable chair

✎ x6

698/C

cuscino \ cushion

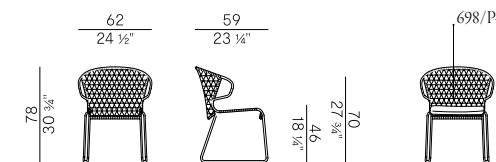

698/P

poltroncina impilabile \ stackable armchair

✎ x6

698/PC

cuscino \ cushion

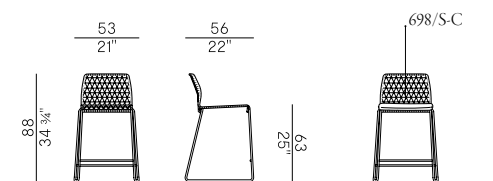

698/S

sgabello basso \ counterstool

698/S-C

cuscino \ cushion

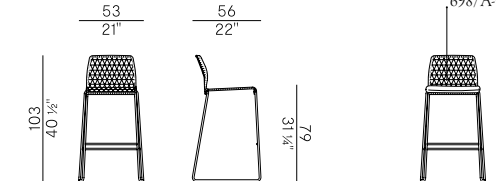

698/A

sgabello alto \ barstool

698/A-C

cuscino \ cushion

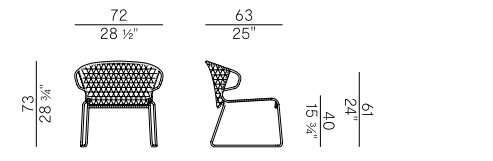

698/LP

poltrona impilabile \ stackable lounge chair

✎ x4

698/LP-C

cuscino \ cushion

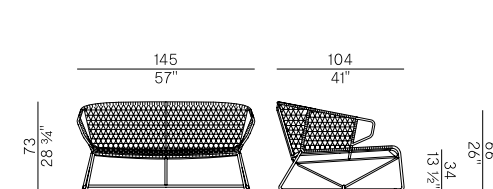

698/D

divano \ sofa

698/D-C1

60x60 cm

698/D-C

105x75 cm

cuscino \ cushion



## VELIS

Design Mario Ferrarini  
pag. 284, 286, 287, 288

Poltroncina pozzetto con struttura in legno massello di iroko e schienale con struttura in tondino d'acciaio verniciato, intrecciato a mano in cordino "Gassa" testa di moro o corda nautica canapa. Seduta imbottita in poliuretano espanso ignifugo. Cuscino schienale incluso. Pannello sedile removibile. Rivestimenti di collezione.

Dining tub chair with solid iroko wood structure and backrest with structure in painted steel rod, hand-woven in "Gassa" dark brown rope or hemp nautical rope. Upholstered seat in fire retardant polyurethane foam. Back cushion included. Removable seat panel. Coverings as per collection.

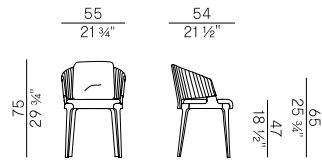

942/PAR-OUT

poltroncina pozzetto \ tub chair

## WELD

Design Busetti, Garuti e Redaelli  
pag. 64, 66-67, 88, 90-91, 92-93, 98, 100-101, 120-121

Collezione di tavolini con struttura in tubo d'acciaio verniciato a polveri epossidiche per outdoor in due diverse altezze e dimensioni. Dettaglio della base intrecciato a mano in corda nautica canapa o cordino "Gassa" testa di moro o beige. Piano in hpl, grès porcellanato ossido nero, legno massello di iroko o legno frassino waterproof.

Collection of coffee tables with structure in epoxy powder coated steel tube for outdoor in two different heights and sizes. Detail of the hand-woven base in hemp nautical rope or "Gassa" dark brown or beige rope. Top in hpl, black oxide laminated porcelain, solid iroko wood or waterproof ash wood.



865/TCB

tavolino \ coffee table

865/TCH

tavolino \ coffee table

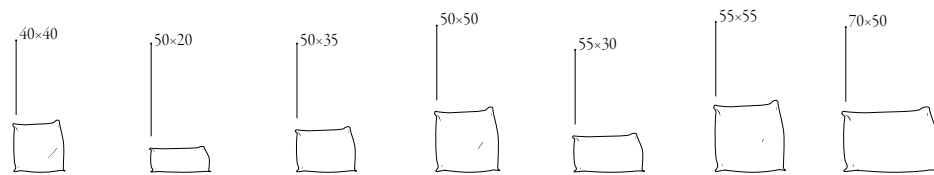

cuscini decorativi \ decorative pillows

# Finishes.



# Outdoor

## ESSENZE SPECIALI / SPECIAL ESSENCES ☁



SU Frassino waterproof \ Waterproof ash  
 EU Iroko \ Iroko  
 EK Mogano tinto noce \ Walnut stained mahogany

## METALLI VERNICIATI / LACQUERED METALS ☁



Bianco goffrato \ White embossed  
 Bianco perla goffrato \ Pearl white embossed  
 Antracite goffrato \ Anthracite embossed  
 Aval goffrato \ Aval embossed  
 Nero goffrato \ Black embossed

## INOX / INOX ☁ ⚓

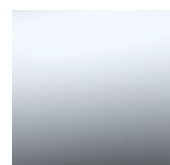

Lucido AISI 316 \ AISI 316 polish

## GRÈS PORCELLANATO / LAMINATED PORCELAIN ☁

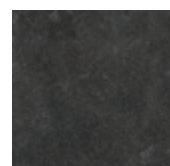

Ossido nero \ Black oxide

## HPL / HPL ☁

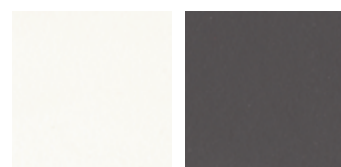

Bianco \ White  
 Antracite \ Anthracite

## CERAMICA / CERAMIC ☁

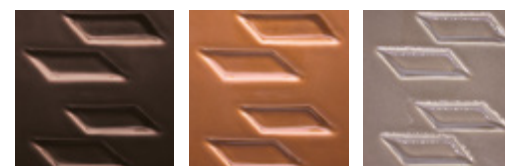

Cioccolato \ Chocolate  
 Pesca \ Peach  
 Grigio sabbia \ Sand grey

## VETRO TEMPERATO / TEMPERED GLASS ☁



Bronzato \ Bronzed

## PIETRE / STONES ☁

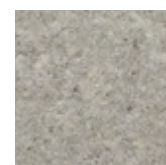

Pietra naturale light grey \ Light grey natural stone



Adatto per uso esterno \ Suitable for outdoor use



Adatto per uso esterno in ambiente salino \ Suitable for outdoor use in salty environments



Articolo ignifugo \ Flame retardant



CORDINI / ROPES ☁️



K1  
Sintetico moka \ Moka syntetic

CORDINI / ROPES ☁️ ⚓



J7 PVC bianco \ PVC white  
G2 PVC antracite \ PVC anthracite  
B1A Gassa beige \ Gassa beige  
F7E - F8F Gassa testa di moro \ Gassa dark brown

CORDA NAUTICA / NAUTICAL ROPE ☁️ ⚓



F7F - F9B Canapa \ Hemp  
D4B Antracite \ Anthracite  
D5B Blu navy \ Blue navy

FETTUCCIA / RIBBON ☁️ ⚓



S4E Fly grigio \ Fly grey  
A7A Gassa beige \ Gassa beige

TRECCIA IMBOTTITA / PADDED BRAID ☁️ ⚓



S2F Antracite \ Anthracite

SHELL (CAT. 1) - 100% Solution Dyed Outdoor Acrylic



E1A Bianco  
E1R Sabbia  
E2D Tronco  
E2C Mattone  
E2A Grigio  
E2B Antracite

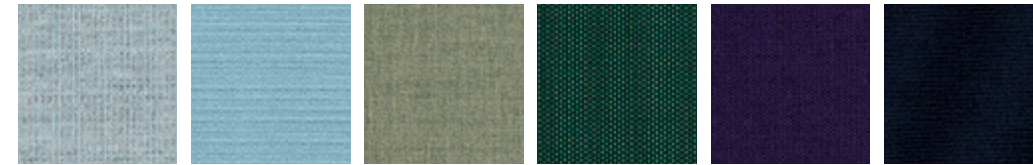

E1L Grigio celeste  
E1G Celeste  
E2G Verde muschio  
E2H Bosco  
E2E Prugna  
E2F Blue navy

Martindale : 30.000 cicli/rubs

Light fastness : 4/5

Fire tests : CAL TB 117:2013 / NFPA 260 / NF EN 1021-1

Sustainability : Standard 100 by Oeko-tex / Greenguard gold certification

Main characteristics : Bleach Cleanable / Breathable comfort / Mold - mildew resistant /

Water & stain resistant / Sun protection / UV - Fade resistant / Landfill free

Technical features: ☁️ ⚓

Care: 🧺 🚫🔥 🚫🧴 🚫🧼 🚫🧊 🚫🧦

SEAL (CAT. 2) - 100% PP

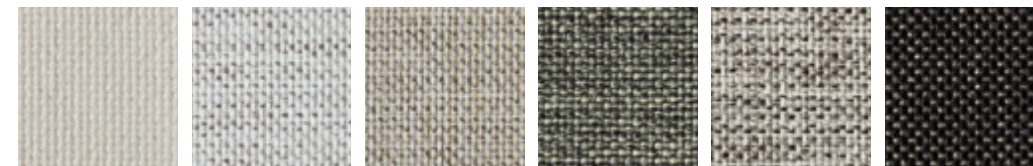

A1M Bianco  
A1N Bianco melange  
A1P Beige  
A1Q Antracite  
A1R Grigio melange  
A1S Nero

Martindale : 40.000 cicli/rubs

Light fastness : 7/8

Fire tests : BS 5852 Cigarette / CAL TB 117:2013

Sustainability : Standard 100 by Oeko-tex / Greenguard gold certification

Main characteristics : Recyclable / Antibacterial / Anallergic / Anti mould, fungus and moths /

Very easy to wash, 40C / Quick dry / Resistant to sea water and chlorinated water

Technical features: ☁️ ⚓

Care: 🧺 🚫🔥 🚫🧴 🚫🧼 🚫🧊 🚫🧦



**SKIPPER (CAT. 3) - 100% Solution Dyed Outdoor Acrylic**

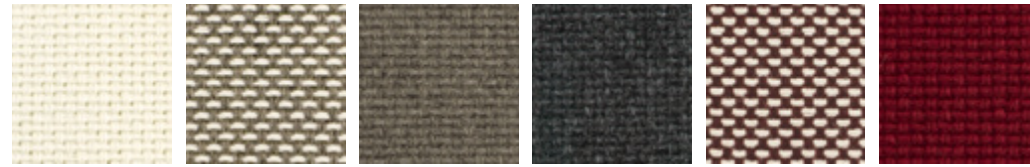

B4A Panna  
B4B Panna grigio  
B4C Grigio  
B4D Antracite  
B4E Ribes  
B4F Rubino

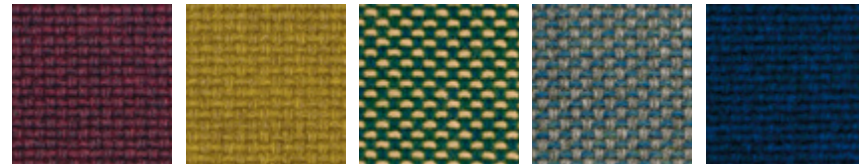

B4G Prugna  
B4H Senape  
B4I Verde  
B4J Grigio celeste  
B4K Blue navy

Martindale : 20.000 cicli/rubs  
Light fastness : 7/8  
Main characteristics : Stain repellent / Anti-mould / Teflon treatment

Technical features:

Care:

**STAR (CAT. 3) - 99% Solution Dyed Outdoor Acrylic, 1% PL**

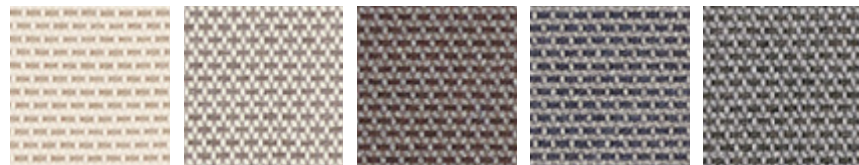

B4Q Sabbia  
B4R Grigio  
B4V Tronco  
B4T Blu oltremare  
B4U Antracite

Martindale : 30.000 cicli/rubs  
Light fastness : 4/5  
Fire tests : CAL TB 117:2013 / NFPA 260 / NFEN 1021-1  
Sustainability : Standard 100 by Oeko-tex / Greenguard gold certification  
Main characteristics : Bleach Cleanable / Breathable comfort / Mold - mildew resistant / Water & stain resistant / Sun protection / UV / Fade resistant Landfill free

Technical features:

Care:

**SUMMER (CAT. 4) - 100% PL Flame retardant**

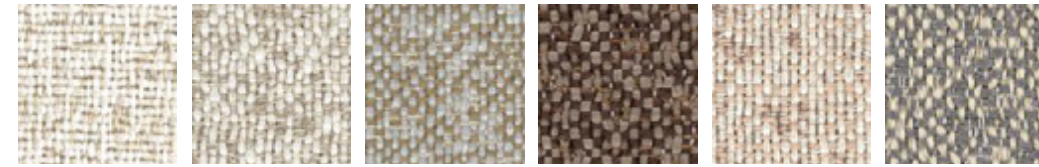

B6A Bianco  
B6B Avorio  
B6C Pietra  
B6N Terra  
B6D Cipria  
B6P Alluminio

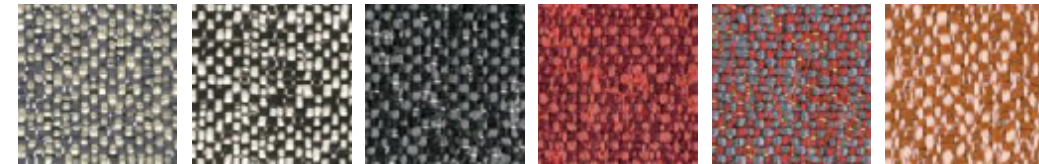

B6E Grigio  
B6F Sale e pepe  
B6G Antracite  
B6H Ruggine  
B6I Corniola  
B6Q Terra di siena

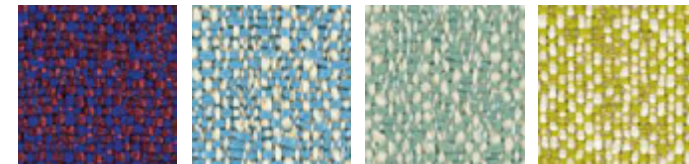

B6M Red-bluc  
B6R Azzurro  
B6S Giada  
B6K Alga

Martindale : 50.000 cicli/rubs  
Light fastness : 7  
Fire tests : NFPA 260 / CAL TB 117:2013 / B1 DIN 4102, Part 1 / BS 5852 Cigarette / BS 5852 Match / BS 7176 / M1 NFP902-503-504-505 / IMO 8 Upholstery  
Sustainability : Standard 100 by Oeko-tex / Greenguard gold certification  
Main characteristics : Bleach Cleanable / Breathable comfort / Mold - mildew resistant / Water & stain resistant / Sun protection / UV - Fade resistant / Landfill free

Technical features:

Care:



**SOUL (CAT. 4) - 100% Polyolefinic FR**



ZX Bianco    ZU Panna    ZY Beige    ZT Nocciola    ZK Arancio    T1P Grigio melange

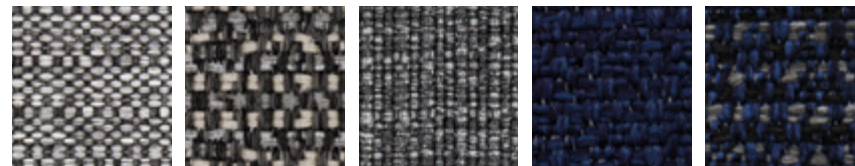

ZV Grigio    T1M Nero melange    ZW Nero    T1N Blu    T1Q Blu melange

Martindale : 40.000 cicli/rubs  
 Light fastness : 6  
 Fire tests : UNI 8456 - 9174 - Class 1 / EN 1021-1/2 / CAL TB 117:2013 / B1 DIN 4102, Part 1 / NFPA 260:2013 - Class 1 / IMO 2010 FTP CODE Part 8 / EN 13773 (2004) Classe 1 / DIN EN 1021 Teil 1+2 / BS 5852 CRIB 5 / IMO Res. A652 (16)

Technical features:

Care:

**SHIP (CAT. 4) - 57% PC, 43% PP**

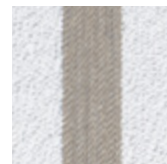

A2A  
 Bianco-beige

Martindale : 30.000 cicli/rubs  
 Light fastness : 7  
 Fire tests : CAL TB 117:2013 / BS 5852 Cigarette

Technical features:

Care:

**SUNSET (CAT. 4) - 100% Solution Dyed Outdoor Acrylic**

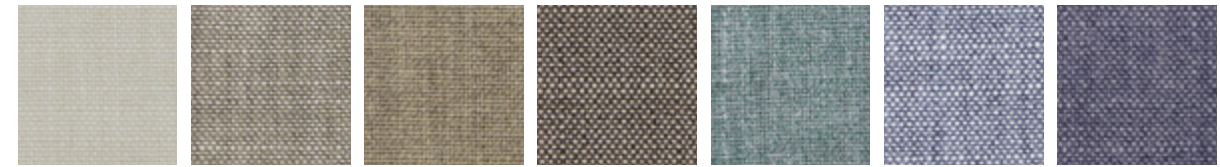

T1A Panna    T1B Beige chiaro    T1C Beige    T1D Tronco    T1L Cielo    T1E Light blu    T1F Blu



T1G Grigio    T1H Grigio chiaro    T1I Nocciola    T1J Grigio scuro    T1K Antracite

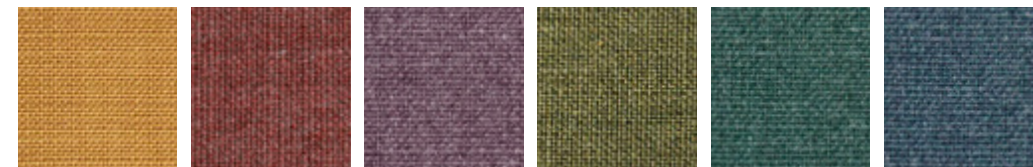

T1R Senape    T1S Terracotta    T1T Viola    T1U Muschio    T1V Bosco    T1W Ottanio

Martindale : 50.000 cicli/rubs  
 Light fastness : 7/8  
 Fire tests : CAL TB 117:2013 / NFPA 260-UFAC Class 1  
 Sustainability : Standard 100 by Oeko-tex / Greenguard gold certification  
 Main characteristics : Colour fast to light / In-outdoor / Mould resistant / Water repellent / Breathable / Stain resistant / High abrasion resistant

Technical features:

Care:



TRECCIA IN FILATO DI POLIPROPILENE (PER I TAPPETI CLUE) ☁  
BRAIDS IN POLYPROPYLENE YARN (FOR CLUE CARPETS)

MODELLO TONDO / ROUND MODEL

971/C - BEIGE



Beige Tortora

971/C - GREEN

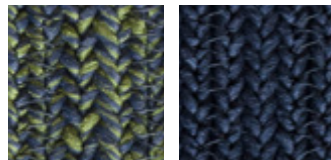

Verde bosco Blu

971/C - GREY

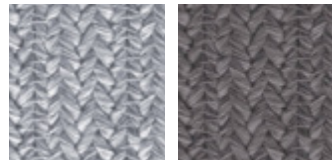

Grigio perla Grigio

MODELLO RETTANGOLARE / RECTANGULAR MODEL

971/R - BEIGE

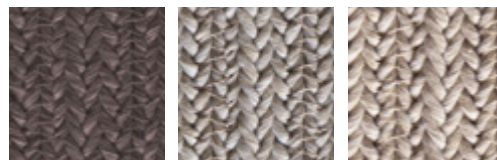

Marrone Tortora Beige

971/R - BLUE

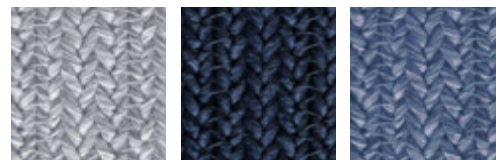

Grigio perla Blu Carta da zucchero

971/R - GREY

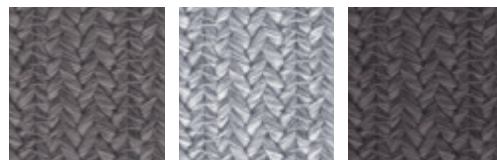

Grigio Grigio perla Grigio antracite

971/R - PETROL

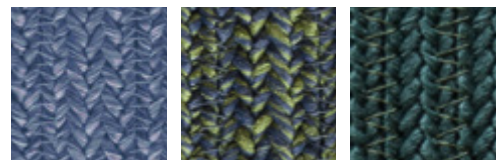

Carta da zucchero Verde bosco Petrolio

OUTDOOR COLLECTION

Art direction & Graphic project

— Chiara Andreatti Studio

Project Coordination

— Potocco Corporate Image Team

Photos

— Francesca Ferrari

pages 3-11, 23-35, 38, 42-52, 54, 57-63, 66-67, 69, 76-87,  
180-187, 204-227, 232-233, 236-237, 245-251

— Giulio Gbirardi

pages 23, 64, 68, 70-73, 88, 92-109, 112-114, 117-123,  
128-135, 138, 142, 146-150, 171 - 173, 176-179, 188-191,  
195, 199, 241

— Miro Zagnoli

pages 252, 256-257, 264, 270-275, 280-284, 288-293

— Potocco Corporate Image Team

pages 15-21, 37, 40, 41, 53, 75, 91, 110, 111, 124-127, 136-137,  
140, 144, 152, 168, 174, 192, 196, 197, 200-203, 228-230, 234,  
235, 238, 239, 242, 255, 258-263, 267-269, 276-279, 286, 287,  
294-295, 314-322

Styling

— Martina Lucatelli Studio

pages 28-247

— Ilaria Baccocchi

pages 252-293

Printing

— Grafiche Antiga

Thanks to

— Yota Viktoratou

— Martina Dalla Bona

— Gianluca Bellomo

— Paul Abbiati

— Marta Marcolin

Italy, December 2022

POTOCO

Via Indipendenza 4  
33044 - Manzano, Udine - Italy  
T. +39 0432 745111  
© 2023 Potocco S.p.A.  
info@potocco.it

Potocco USA  
Hickory, NC 28602  
United States of America  
customerservice@potocco-usa.com



# Credits

## CONTRIBUTORS:

Astep  
Bitossi Ceramiche  
Bitossi Home  
Bormioli Rocco  
Daria Dazzan Ceramics  
Frama  
Laboratorio Pesaro  
Laura Sattin Glassworks  
Mmairo  
Paola C.  
Rivesto Italia  
Santa & Cole  
Stelton  
Stories of Italy  
Svenskt Tenn  
6:AM Glassworks

Potocco reserves the right to introduce any changes to its own models without prior notice. Color tones may vary from one dye lot to another.

© 2023 by Potocco S.p.A.  
All rights reserved



The mark of  
responsible forestry

"Richiedi i nostri  
prodotti certificati  
FSC®"

[www.potocco.it](http://www.potocco.it)





