

POTOCCO ITALY

Preview
2023

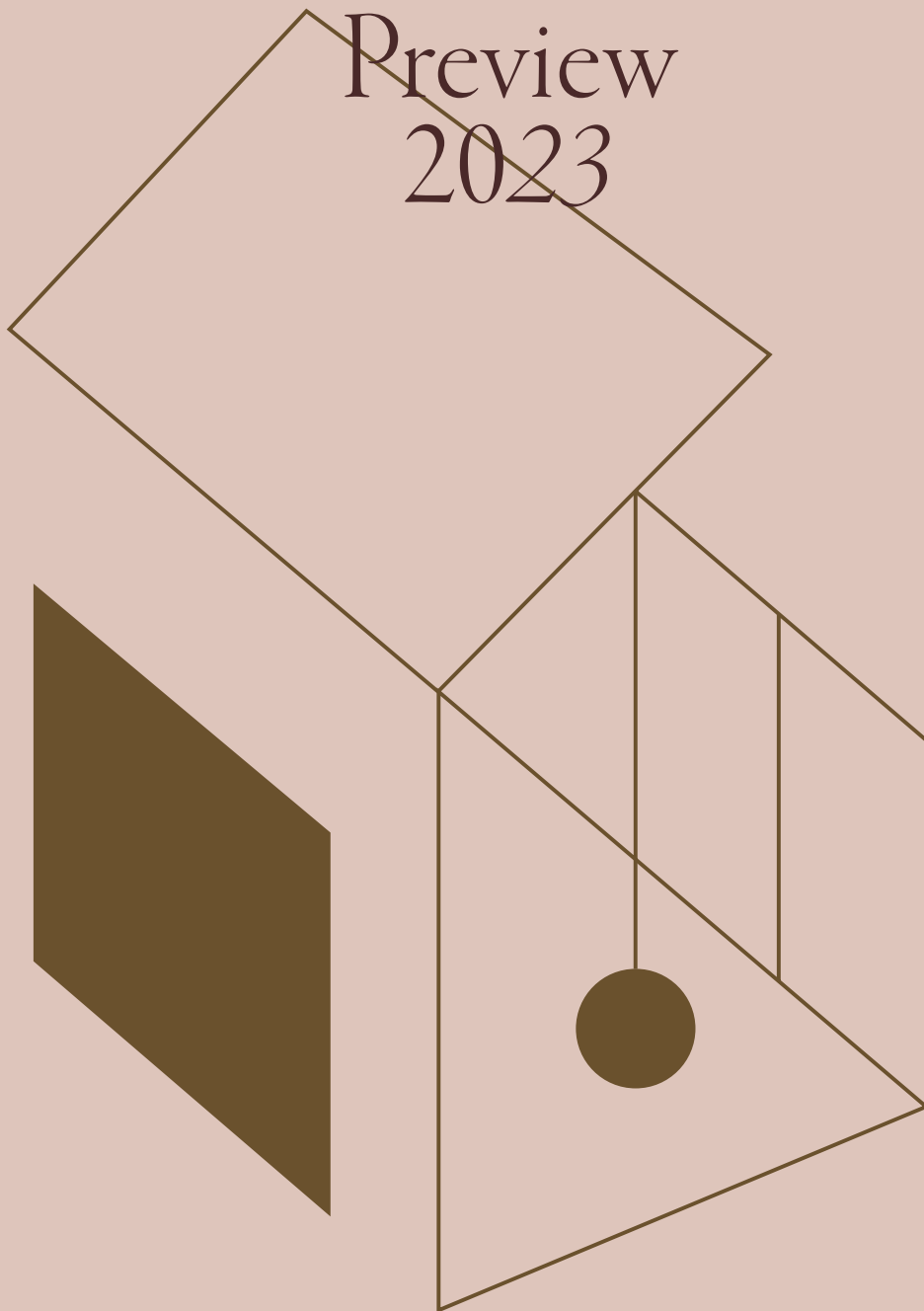

Design. Since 1919.

POTOCCO
ITALY

INDEX

INDOOR COLLECTIONS



CONCHA
Art. 905/PL
pagina 44



GRAPHIC
Art. 955/TR
pagina 12



GRAPHIC
Art. 955/O
pagina 12



GRAPHIC
Art. 955/TGC
pagina 12



JADE
Art. 953/D
pagina 24



MINIMA
Art. 949
pagina 8



SHAPE
Art. 954/TBR1
pagina 36



SHAPE
Art. 954/TBR2
pagina 36

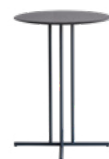

GRAPHIC
Art. 955/TAC
pagina 12



GRAPHIC
Art. 955/TC-40
pagina 12



GRAPHIC
Art. 955/TC-60
pagina 12



GRAPHIC
Art. 955/TC-80
pagina 12

OUTDOOR COLLECTIONS



AGRA
Art. 688/ATG-O-OUT
pagina 50



GRAPHIC
Art. 955/TR-OUT
pagina 56



GRAPHIC
Art. 955/O-OUT
pagina 56



GRAPHIC
Art. 955/TGC-OUT
pagina 56



GRAPHIC
Art. 955/SCR
pagina 12



HIRU
Art. 947/S
pagina 40



HIRU
Art. 947/A
pagina 40



JADE
Art. 953/TBA
pagina 24

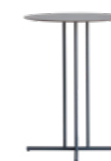

GRAPHIC
Art. 955/TAC-OUT
pagina 56



GRAPHIC
Art. 955/TBC-40-OUT
pagina 56



GRAPHIC
Art. 955/TBC-60-OUT
pagina 56



GRAPHIC
Art. 955/TBC-80-OUT
pagina 56



JADE
Art. 953/TB
pagina 24



JADE
Art. 953/TBO
pagina 24



JADE
Art. 953/TBT
pagina 24



OLA
Art. 923/O
pagina 64

Potocco Preview

2023

Suggerimenti architettoniche, una palette delicata e mediterranea e una filosofia dell'abitare che invita alla leggerezza: Potocco presenta i nuovi progetti e le nuove collezioni, contraddistinte da un'estetica sofisticata e ambiziosa ma al tempo stesso accogliente. Prodotti e ambienti danno forma alla visione dell'abitare contemporaneo di cui l'azienda si fa portavoce: un invito a godere gli spazi domestici riscoprendo una dimensione temporale rallentata, intima e personale.

Architectural fascination, a delicate and Mediterranean palette and a living philosophy that recalls the lightness: Potocco presents its new projects and collections, characterized by a sophisticated, ambitious and wel-

coming aesthetics. The latest collections show the contemporary living vision advocated by the company: it is a call to use domestic spaces rediscovering a slowed temporal dimension, both intimate and personal.

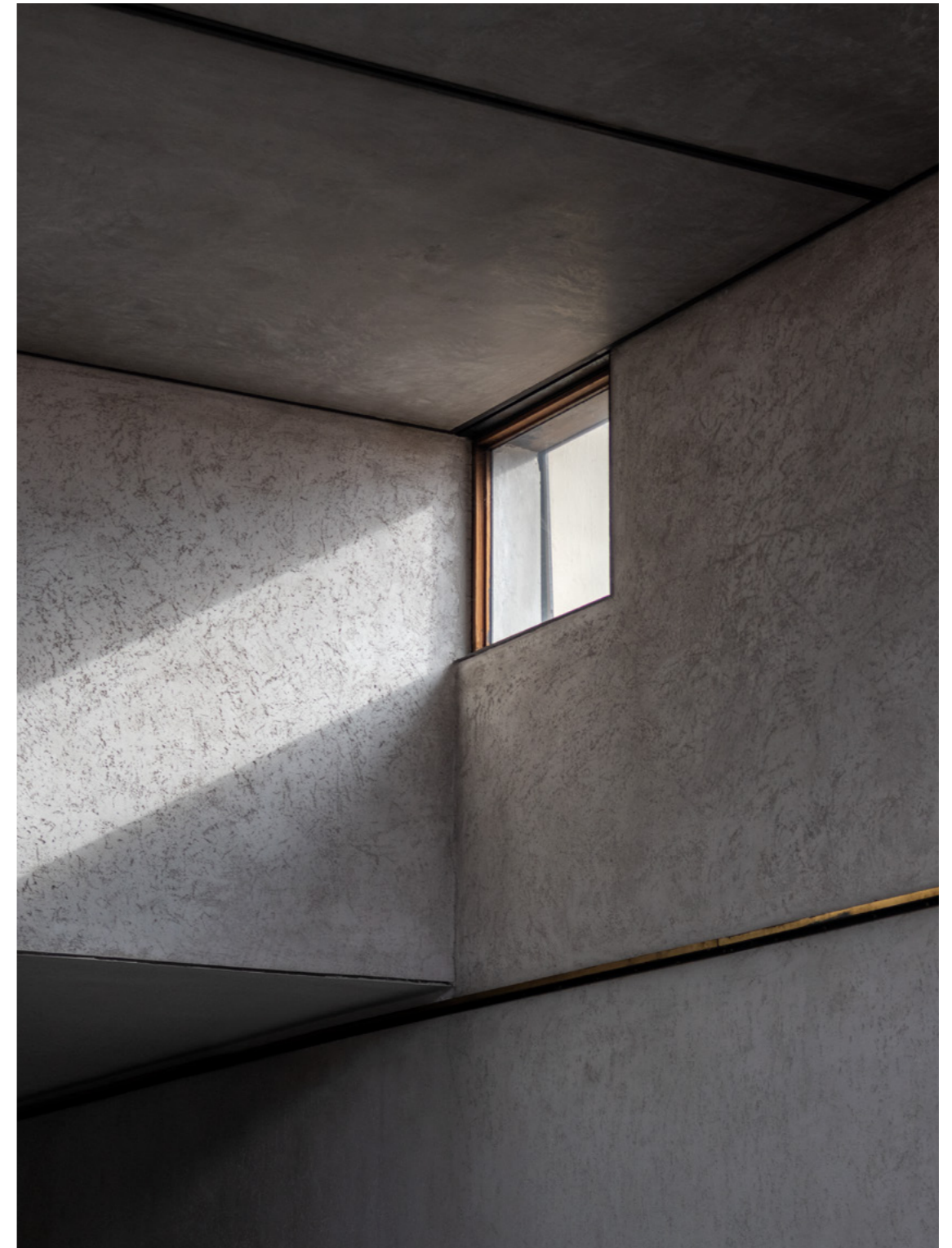



Indoor collections

— Tra le novità dedicate all'indoor, Potocco presenta quest'anno i tavolini Shape disegnati da Storagemilano, la collezione Graphic di Victor Vasilev e Mario Ferrarini, il sistema di divani componibili Jade di Hanne Willmann e la sedia Minima di Mario Ferrarini. Non mancano inoltre gli ampliamenti di alcune delle collezioni best seller dell'azienda: la poltrona lounge Concha di Stephan Veit e gli sgabelli in due altezze Hiru di Mario Ferrarini.

Among the latest indoor products, this year Potocco presents the Shape coffee tables designed by Storagemilano, the Graphic collection by Victor Vasilev and Mario Ferrarini, the Jade modular sofa system by Hanne Willmann and the Minima chair by Mario Ferrarini. There are also additions to some of the best seller collections of the company: the Concha lounge chair by Stephan Veit and the Hiru stools, available in two different heights, by Mario Ferrarini.

Minima

Minima è una nuova seduta interamente in legno disegnata da Mario Ferrarini, nata dall'idea di realizzare un oggetto accogliente e robusto, dalle linee fluide ed energiche. Un progetto rassicurante nella sua visione precisa e puntuale, che si contraddistingue per i dettagli pesati e il profilo rigoroso. Il multistrato della seduta e dello schienale si sviluppa seguendo una sinuosa armonia; le gambe in massello di frassino sono lavorate per accogliere lo schienale grazie ad una elegante torsione che ne esalta gli effetti di luce e la lavorazione raffinata tipica di Potocco, ponendo l'accento sulla magistrale capacità dell'azienda di lavorare con il legno.

Minima is the new chair entirely made out of wood, designed by Mario Ferrarini, developed from the idea to create a welcoming and robust object with fluid and energetic lines. It is a reassuring project in its precise and accurate vision that stand out for its thoughtful details and rigorous profile. The plywood of the seat and the backrest is designed following a sinuous harmony and the legs in solid ash wood are worked to accommodate the backrest thanks to an elegant twist that enhances the light effects and the refined workmanship typical of Potocco, emphasizing the company's masterful ability to work with wood.



Minima 949
Sedia dining / Dining chair

MINIMA

Design Mario Ferrarini

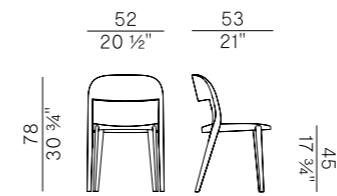

949  x4
sedia dining \ dining chair

FINITURE / FINISHES

STRUTTURA IN FRASSINO
ASH FRAME

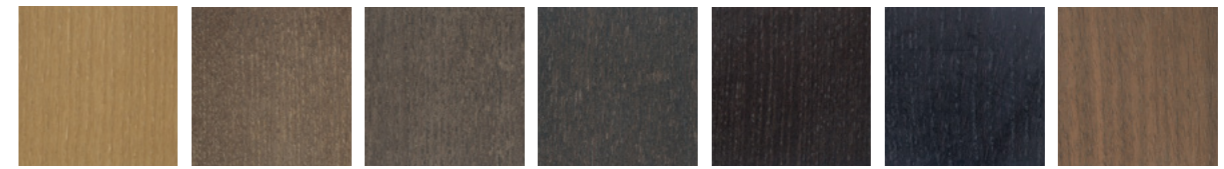

SG

Anilina beige \
Beige aniline

SC

Biscotto \ Biscuit

HJ

Moka \ Moka

HK

Grigio plumbeo \
Dark grey

HL

Wengé \ Wengé

HP

Carbone \ Carbon

SN

Noce \ Walnut

STRUTTURA IN FRASSINO TINTO COLORI SPECIALI
ASH WOOD FRAME STAINED SPECIAL COLORS

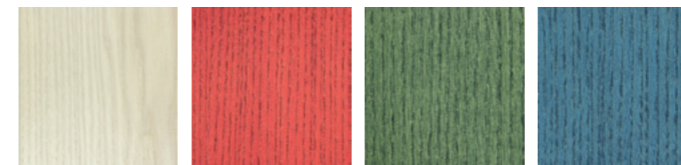

White

Cherry

Olive green

Bluette



Graphic

Il progetto di Graphic è stato sviluppato da Victor Vasilev e Mario Ferrarini come estensione della collezione di sedute Keel mantenendo lo stesso codice compositivo. Una struttura di elementi sottili e geometrici si unisce armoniosamente con dei piani funzionali, dando vita a tavoli, panca, scrittoio e tavolini accessori con piani anche in massello di frassino. Il risultato finale è una collezione caratterizzata da un'assoluta semplicità strutturale che garantisce la perfetta combinazione con le famiglie di sedute firmate Potocco.

Graphic has been designed by Victor Vasilev and Mario Ferrarini as an extension of the Keel chair collection, maintaining the same composition characteristics. The structure, composed of thin and geometrical elements, is harmoniously combined with functional surfaces, creating tables, the bench, the writing desk and complementary coffee tables, with top available also in solid ash wood. The result is a collection characterized by an absolute structural simplicity that ensures its perfect combination with the Potocco seat families.





Graphic 955/TGC - 955/TAC
Tavolo e tavolo alto / *Table and High table*



Graphic 955/TR-955/O
Tavolo e panca / *Table and bench*



Graphic 955/TBC-80 - 955/TBC-60 - 955/TBC-40
Tavolini / *Coffee tables*



Graphic 955/SCR
Scrittoio / *Writing desk*



Graphic 955/TGC-955/TR-955/TAC
Tavoli / Tables

GRAPHIC

Design M+V

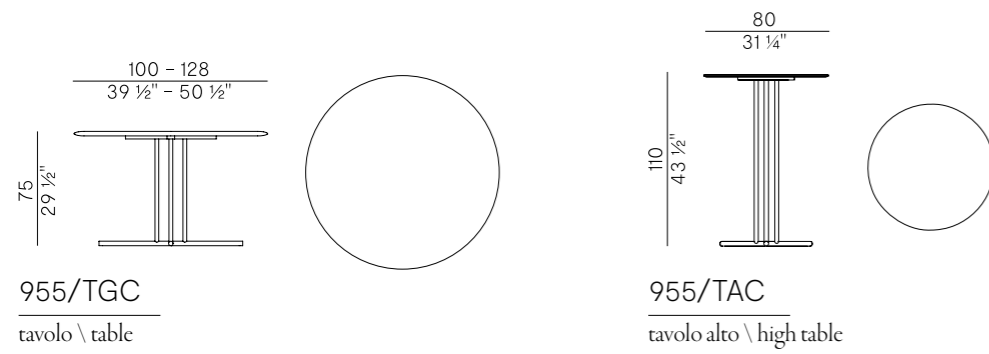

955/TGC

tavolo \ table

955/TAC

tavolo alto \ high table

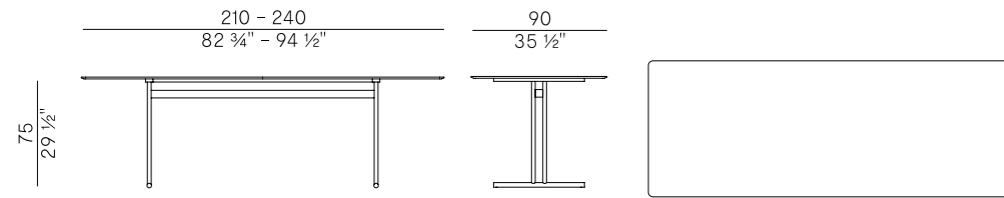

955/TR

tavolo \ table

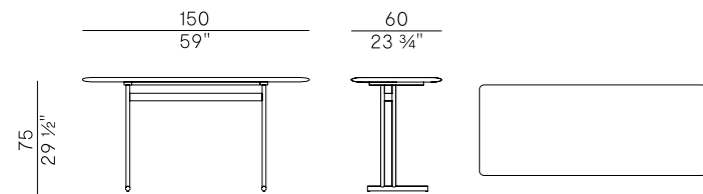

955/SCR

scrittoio \ writing desk

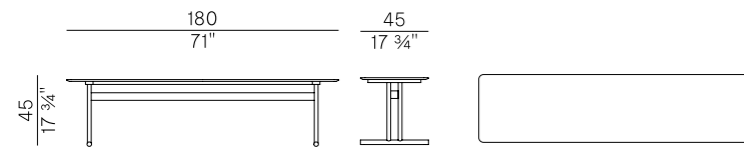

955/O

panca \ bench

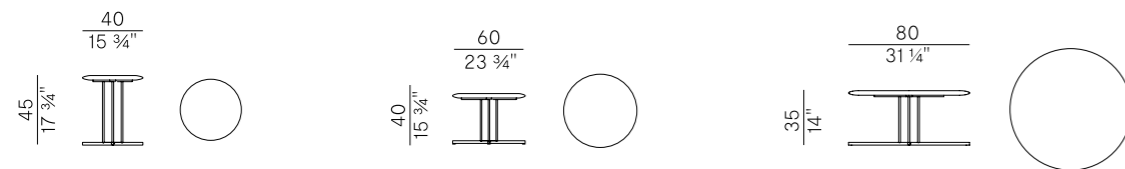

955/TBC-40

tavolino \ coffee table

955/TBC-60

tavolino \ coffee table

955/TBC-80

tavolino \ coffee table

FINITURE / FINISHES

BASE IN METALLO VERNICIATO
LACQUERED METAL BASE

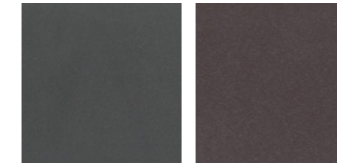

Antracite goffrato \
Anthracite embossed

Aval goffrato \
Aval embossed

PIANO IN FRASSINO
ASH TOP

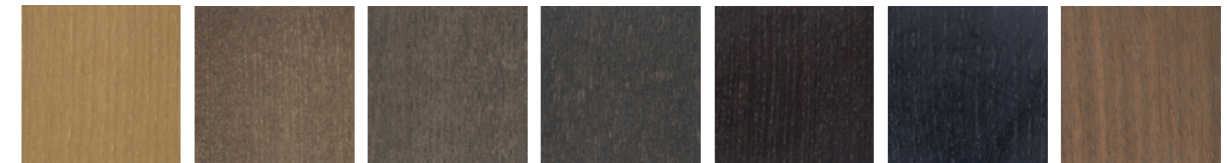

SG
Anilina beige \
Beige aniline

SC
Biscotto \ Biscuit

HJ
Moka \ Moka

HK
Grigio plumbeo \
Dark grey

HL
Wengé \ Wengé

HP
Carbone \ Carbon

SN
Noce \ Walnut

PIANO IN MARMO (955/TBC-40, 955/TBC-60, 955/TBC-80)
MARBLE TOP

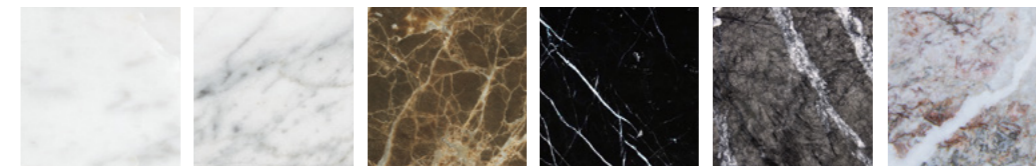

Bianco Carrara lucido \
Glossy White Carrara

Bianco Carrara opaco \
Matt White Carrara

Dark Emperador \
Dark Emperador

Nero Marquina \
Nero Marquina

Grigio Carnico \
Grigio Carnico

Fior di pesco \
Fior di pesco

Jade

Hanne Willmann disegna Jade: un sistema di divani e tavolini caratterizzati da profili sinuosi e forme morbide e organiche che rimandano alla natura. Questa collezione segna per Potocco un importante passo avanti nella creazione di una proposta sempre più completa dedicata allo spazio living, introducendo a catalogo un nuovo sistema di divani componibili.

Il sistema di sedute si compone di 9 moduli ed è completato da 4 tavolini che possono trovare diverso uso e collocazione tra i moduli delle composizioni o fronte divano. Grazie alla loro unicità, tutti gli elementi possono essere utilizzati singolarmente o combinati creando isole di comfort sempre diverse e fluide che si adattano agli spazi e alle situazioni.

Hanne Willmann designs Jade, a collection of sofas and tables characterized by sinuous profiles and delicate and organic shapes that echo nature. This collection represents an important step for Potocco in the creation of a more complete offer dedicated to the living space, introducing a new system of modular sofas.

The modular system is composed of 9 units and is completed by 4 coffee tables that can be placed differently between the units or in front of the sofa and can thus be used in various ways. Thanks to their uniqueness, every element can be used singularly or combined, creating always different and fluid comfort islands adaptable to every space and situation.



Jade 953/D, Divano componibile / *Modular sofa*
Jade 953/TBA, Tavolino / *Coffee table*





Jade 953/TBA - 953/TBO - 953/TBT - 953/TB
Tavolini / *Coffee tables*

JADE

Design Hanne Willmann

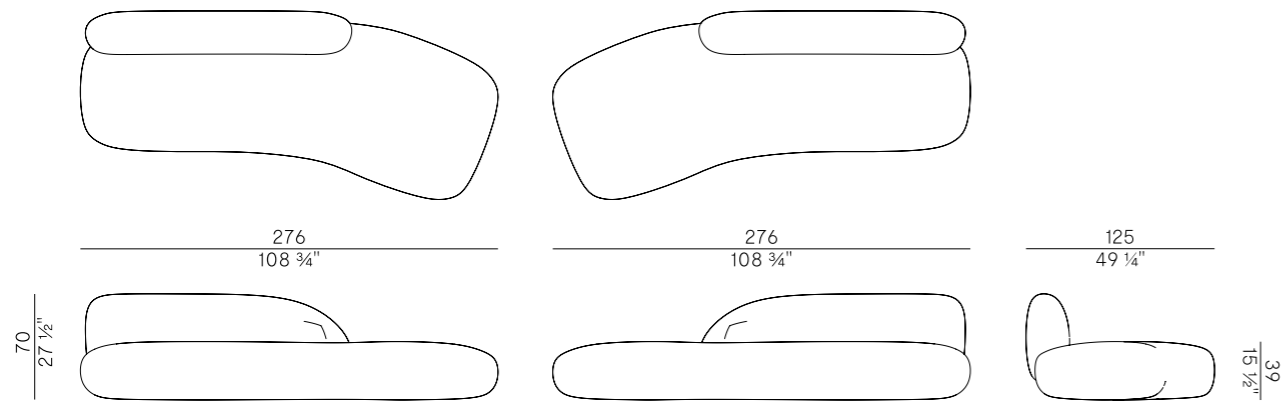

953/RE-DX, 953/RE-SX

modulo recamiere destro e sinistro \ right and left reclining unit

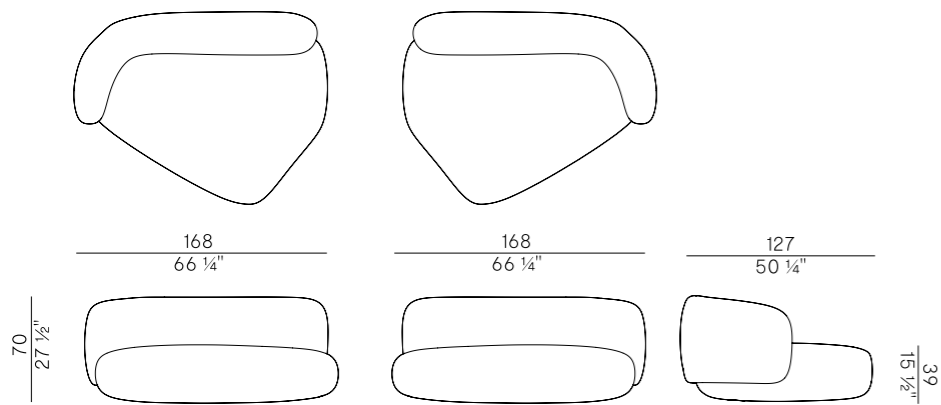

953/OC-DX, 953/OC-SX

modulo off-shape corner destro e sinistro \ right and left off-shape corner unit

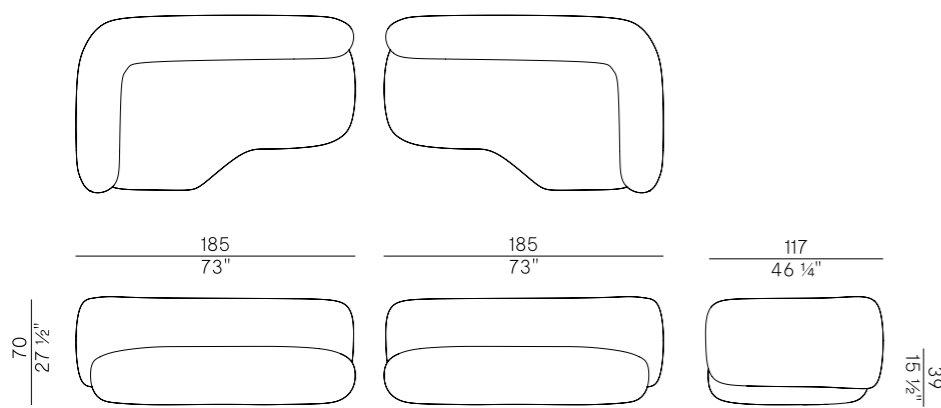

953/CC-DX, 953/CC-SX

modulo combi corner destro e sinistro \ right and left combi corner unit

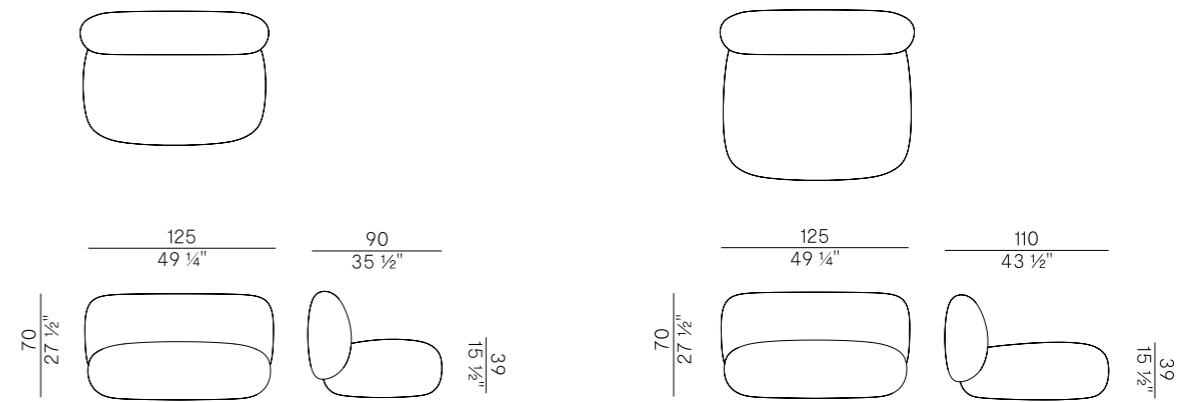

953/DM

modulo intermedio \ intermediate unit

953/DML

modulo intermedio large \ large intermediate unit

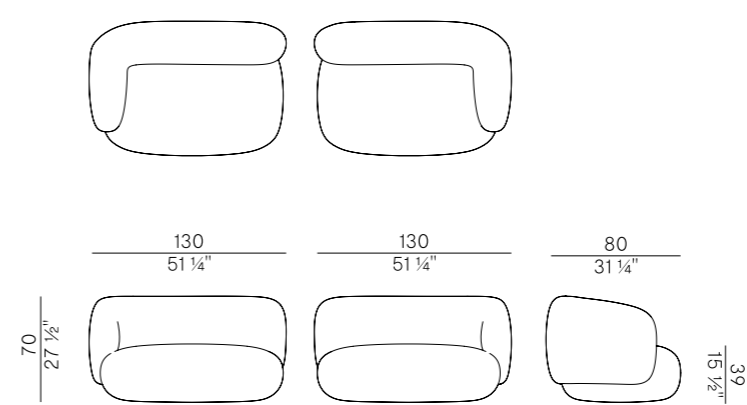

953/DT-DX, 953/DT-SX

modulo corner destro e sinistro \ right and left corner unit

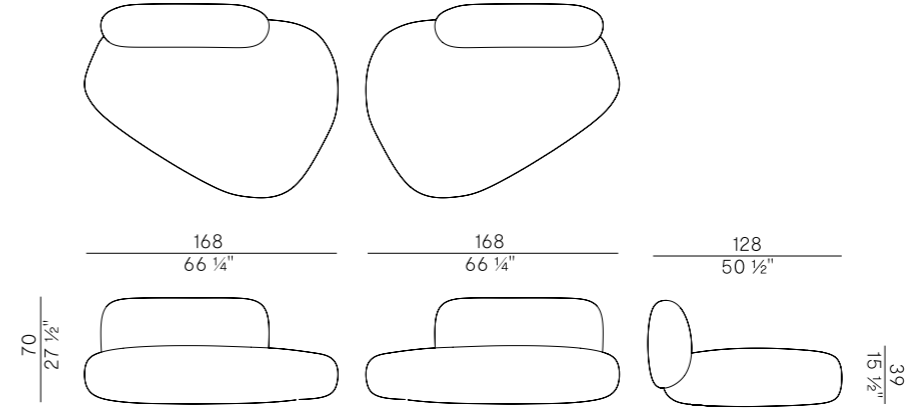

953/OCL-DX, 953/OCL-SX

modulo off-shape chaise longue destro e sinistro \ right and left off-shape chaise longue unit

JADE

Design Hanne Willmann

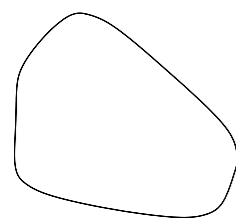

146

57 1/4"

135

53 1/4"

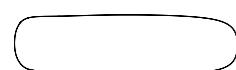

39

15 1/2"

953/OL

modulo off-shape pouf \ off-shape pouf unit



53

21"

75

29 3/4"



44

17 1/2"

953/O

modulo off-shape pouf small \ off-shape small pouf unit

ESEMPI DI COMPOSIZIONE \ COMPOSITION EXAMPLES

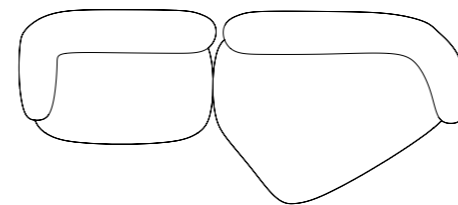

modulo corner destro, modulo off-shape corner sinistro \
right corner unit, left off-shape corner unit

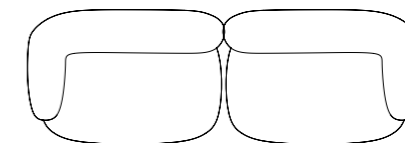

modulo corner destro, modulo corner sinistro \
right corner unit, left corner unit

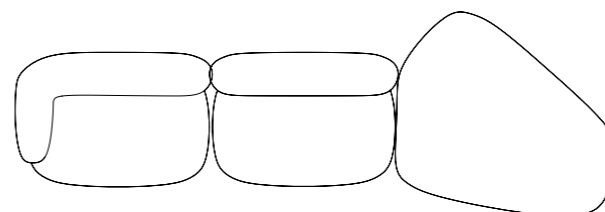

modulo corner destro, modulo intermedio, modulo off-shape pouf \
right corner unit, intermediate unit, off-shape pouf unit

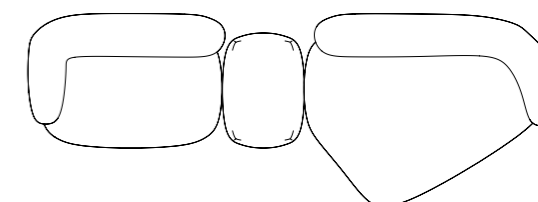

modulo corner destro, modulo off-shape pouf small, modulo off-shape corner sinistro \
right corner unit, off-shape small pouf unit, left off-shape corner unit

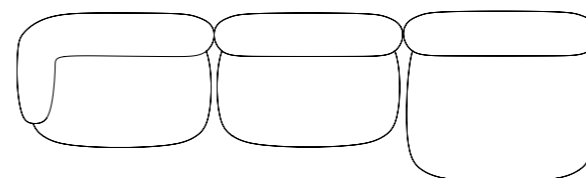

modulo corner destro, modulo intermedio, modulo intermedio large \
right corner unit, intermediate unit, large intermediate unit

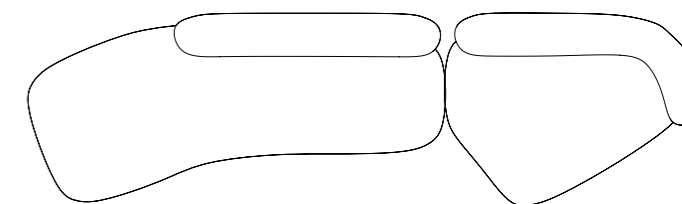

modulo recamiere sinistro, modulo off-shape corner sinistro \
right and left recamiere unit, left off-shape corner unit

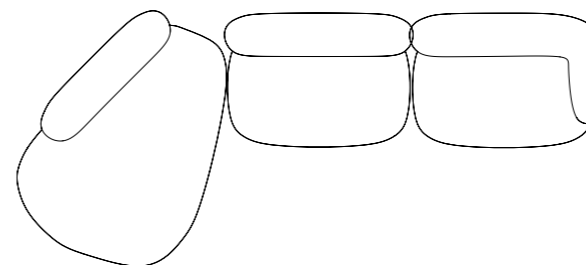

modulo off-shape chaise longue destro, modulo intermedio, modulo corner sinistro \
right off-shape chaise longue unit, intermediate unit, left corner unit

JADE

Design Hanne Willmann

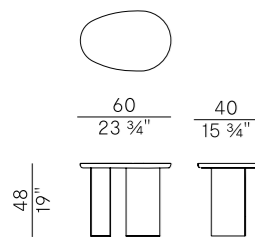

953/TBA
tavolino ponte alto \ high side table

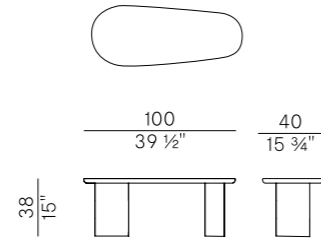

953/TB
tavolino ponte basso \ low side table

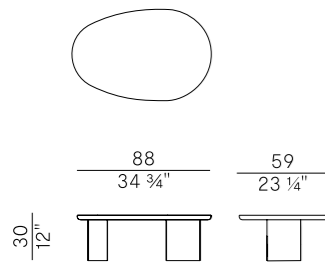

953/TBO
tavolino ovale \ oval coffee table

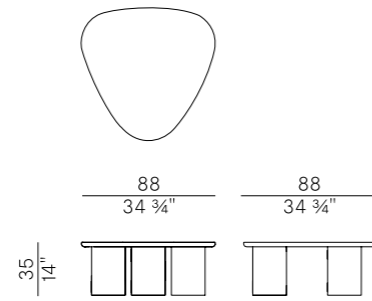

953/TBT
tavolino triangolare \ triangular coffee table

FINITURE TAVOLINI / COFFEE TABLES FINISHES

BASE IN FRASSINO

ASH BASE



SG Anilina beige \ Beige aniline	SC Biscotto \ Biscuit	HJ Moka \ Moka	HK Grigio plumbeo \ Dark grey	HL Wengé \ Wengé	HP Carbone \ Carbon	SN Noce \ Walnut
---	---------------------------------	--------------------------	--	----------------------------	-------------------------------	----------------------------

PIANO IN MARMO

MARBLE TOP

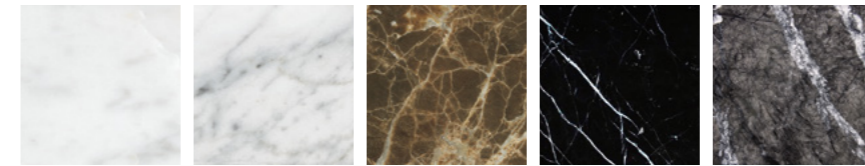

Bianco Carrara lucido \ Glossy White Carrara	Bianco Carrara opaco \ Matt White Carrara	Dark Emperador \ Dark Emperador	Nero Marquina \ Nero Marquina	Grigio Carnico \ Grigio Carnico
---	--	------------------------------------	----------------------------------	------------------------------------

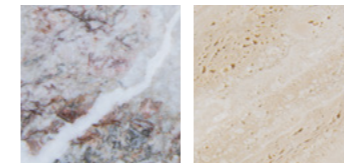

Fior di pesco \ Fior di pesco	Travertino \ Travertino
----------------------------------	----------------------------

Shape

La famiglia di coffee table Shape disegnata da STORAGEMILANO è caratterizzata da un piano in vetro dalla forma squadrata che lascia intravedere il gioco di geometrie della base in legno massello. Segno distintivo del progetto, la struttura è composta da rettangoli diamantati che si incontrano a formare una croce, fissati da giunti metallici in ottone che impreziosiscono ulteriormente il disegno. Disponibili in due diverse altezze e dimensioni, i tavolini Shape possono essere utilizzati sia in coppia che singolarmente, per diventare protagonisti di spazi living contemporanei e affiancare l'ampia collezione di proposte indoor e outdoor dell'azienda.

The coffee table family, designed by STORAGEMILANO, is characterized by a squared-shaped glass top that let you catch a glimpse of the geometrical design of the frame in solid ash wood. The structure is a distinguishing feature of the project and consists of diamond-shaped rectangles that meet to form a cross, secured by brass metal joints that further embellish the design. The Shape coffee tables are available in different heights and dimensions and can be used in pairs or individually to become the protagonists of modern living spaces and complement the wide indoor and outdoor collections of the company.



Shape 954/TBR1 - 954/TBR2
Tavolini / Coffee table

SHAPE

Design StorageMilano

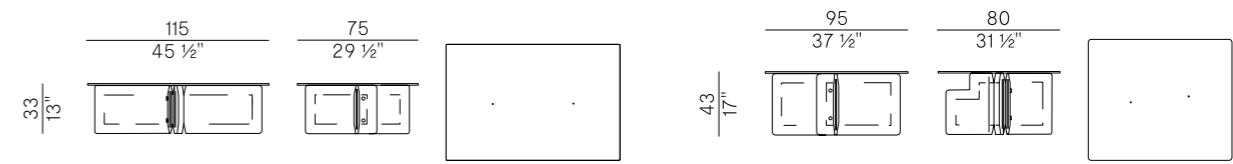

954/TBR1

tavolino \ coffee table

954/TBR2

tavolino \ coffee table

FINITURE / FINISHES

BASE IN FRASSINO

ASH BASE

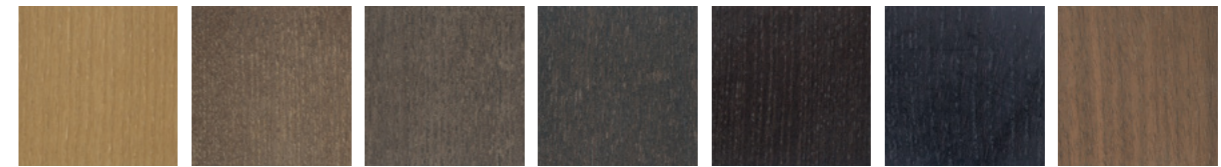

SG

Anilina beige \
Beige aniline

SC

Biscotto \ Biscuit

HJ

Moka \ Moka

HK

Grigio plumbeo \
Dark grey

HL

Wengé \ Wengé

HP

Carbone \ Carbon

SN

Noce \ Walnut

PIANO IN VETRO TEMPERATO

TEMPERED GLASS TOP



Float trasparente \
Transparent float

Bronzato \ Bronzed



Hiru

La famiglia di Hiru disegnata da Mario Ferrarini è composta da sedia e poltroncina, caratterizzate da gambe elicoidali e superfici non planari, alle quali si aggiunge lo sgabello in due altezze. Un rapporto vicendevole dove il legno diventa la struttura su cui si sviluppa il rivestimento, visibile da ogni angolazione della seduta, mostrando così la sapiente capacità dell'azienda nel lavorare il legno come materia viva.

Hiru family was designed by Mario Ferrarini and is composed by chair and armchair, characterized by helicoidal legs and planar surfaces, to which the stool, available in two heights, is added. A reciprocal relationship where the wood becomes the structure on which the upholstery is developed, visible from every angle of the seat, thus demonstrating the company's skillful ability to work wood as a living material.





HIRU

Design Mario Ferrarini

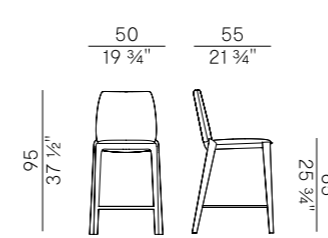

947/S
sgabello basso \ counterstool

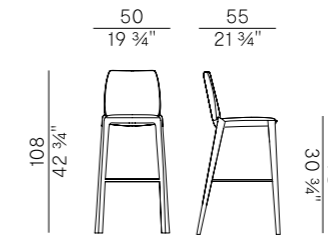

947/A
sgabello alto \ barstool

FINITURE / FINISHES

STRUTTURA IN FRASSINO
ASH FRAME

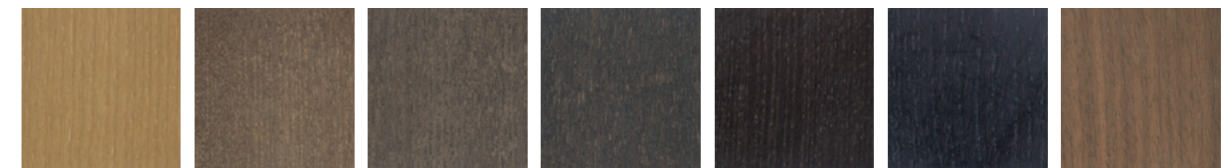

SG Anilina beige \ Beige aniline	SC Biscotto \ Biscuit	HJ Moka \ Moka	HK Grigio plumbeo \ Dark grey	HL Wengé \ Wengé	HP Carbone \ Carbon	SN Noce \ Walnut
---	---------------------------------	--------------------------	--	----------------------------	-------------------------------	----------------------------

Concha

Concha è una famiglia di sedute disegnata da Stephan Veit, dalle linee sobrie ma accattivanti. Le forme essenziali all'insegna della massima versatilità la rendono adatta sia ad ambienti domestici che a spazi contract. Declinata in sedia con o senza braccioli e sgabello, la collezione si arricchisce della poltrona lounge. Le sedute si distinguono per l'avvolgente schienale imbottito e leggermente inclinato, la cui forma ne ha ispirato il nome, mentre le gambe sono in massello di rovere.

Concha is a seat collection designed by Stephan Veit with simple yet charming lines. Its essential shape aims at the highest versatility and makes it suitable for both domestic and contract environments. Available as a chair, with or without armrests, and as a stool, this collection is expanded with the lounge armchair. The seats stand out for the slightly inclined enveloping upholstered backrest, whose shape inspired the name, whereas the legs are in solid oak.



CONCHA

Design Stephan Veit

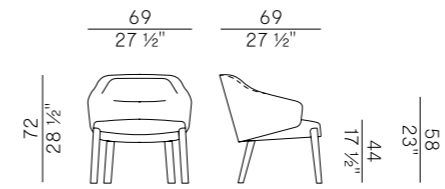

905/PL

poltrona \ armchair

FINITURE / FINISHES

STRUTTURA IN ROVERE

OAK FRAME



UH

Anilina beige \
Beige aniline

UC

Biscotto \ Biscuit

TD

Moka \ Moka

TA

Grigio plumbeo \
Dark grey

TY

Wengé \ Wengé

RQ

Carbone \ Carbon





Outdoor collections

— Le novità outdoor incarnano alcuni dei valori più cari all'azienda, tra cui la storica cultura artigianale e l'invito a creare legami emotivi con i luoghi e con gli oggetti che ci circondano. In occasione del Salone del Mobile 2023, Potocco presenta Graphic disegnata da Victor Vasilev e Mario Ferrarini, declinata in tavoli, panche, scrittoi e tavolini – disponibili anche per indoor. L'azienda propone inoltre alcuni ampliamenti di collezione: Agra di Enrico Franzolini e Ola di Radice Orlandini.

The new collections embody some of the most important values for the company, e.g. the historical manufacturing culture and the call to create emotional connections with the places and objects that surround us. On the occasion of the Salone del Mobile 2023, Potocco presents Graphic, designed by Victor Vasilev and Mario Ferrarini, which includes tables, benches, writing desks and coffee tables – available also for indoor. The company also offers additions to some collections: Agra by Enrico Franzolini and Ola by Radice Orlandini.

Agra

La collezione Agra, disegnata da Enrico Franzolini, si identifica per i tratti raffinati e rigorosi e si declina in sedie e poltroncine impilabili, sgabello e tavolo: arredi capaci di creare ambienti dal gusto sempre nuovo grazie ad un'ampia varietà di materiali e finiture. Il tavolo è presentato in una riedizione inedita con un nuovo piano in legno dogato da outdoor frassino waterproof.

The Agra collection, designed by Enrico Franzolini, stands out for its refined and rigorous traits and includes stackable chairs and armchairs, stool and table. They are pieces of furniture capable of creating environments with an ever-changing taste thanks to a wide variety of materials and finishes. The table is presented in a new re-edition with a new top in slatted wooden top in outdoor waterproof ash.







AGRA

Design Enrico Franzolini

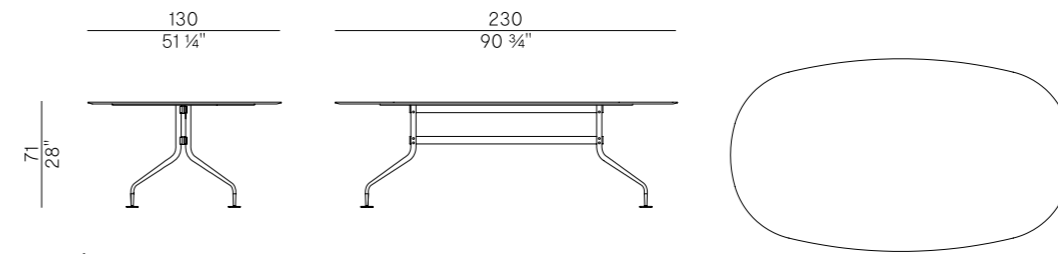

688/ATG-O-OUT

tavolo \ table

FINITURE / FINISHES

BASE IN METALLO VERNICIATO
LACQUERED METAL BASE

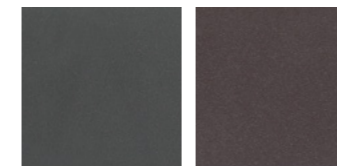

Antracite goffrato \ Anthracite embossed
Aval goffrato \ Aval embossed

PIANO IN HPL
HPL TOP

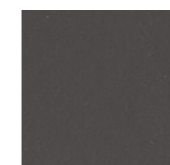

Antracite \ Anthracite

PIANO IN FRASSINO
ASH TOP

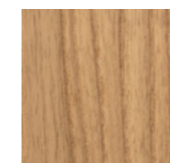

SU
Frassino waterproof \
Waterproof ash

Graphic

Graphic è una collezione firmata da Victor Vasilev e Mario Ferrarini che si contraddistingue per una struttura di elementi sottili e geometrici e la possibilità di essere utilizzata sia per indoor che per outdoor. Le due versioni di Graphic - per interno ed esterno - si differenziano per le finiture: nel caso della variante outdoor infatti tavoli, panca e tavolini accessori sono caratterizzati da base in metallo verniciato e piano in HPL.

Graphic is a collection designed by Victor Vasilev and Mario Ferrarini which is characterized by a structure of thin and geometric elements and the possibility to use it both for indoor and outdoor. Both versions have different finishes, e.g. in the outdoor edition tables, bench and complementary tables feature a painted metal base and top in HPL.



Graphic 955/TGC-OUT
Tavolo / Table



Graphic 955/TR-OUT - 955/O-OUT
Tavolo e panca / *Table and bench*

Graphic 955/TBC-40-OUT - 955/TBC-80-OUT - 955/TBC-60-OUT
Tavolini / *Coffee tables*



Graphic 955/TAC-OUT
Tavolo alto / *High table*



GRAPHIC

Design M+V

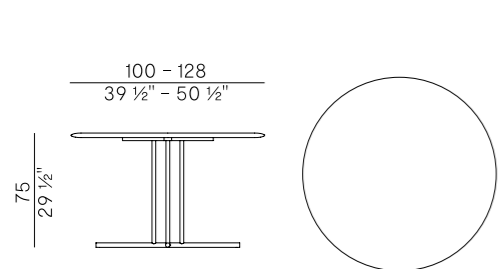

955/TGC-OUT

tavolo \ table

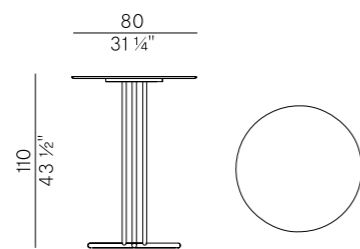

955/TAC-OUT

tavolo alto \ high table

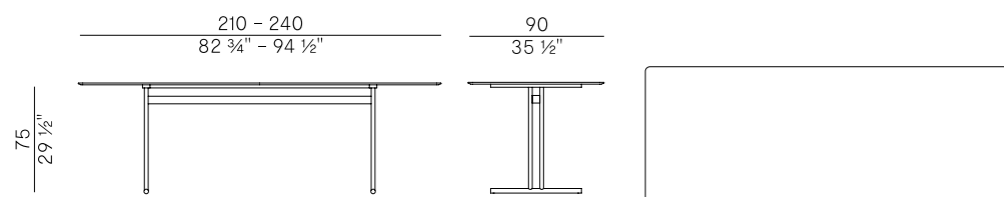

955/TR-OUT

tavolo \ table

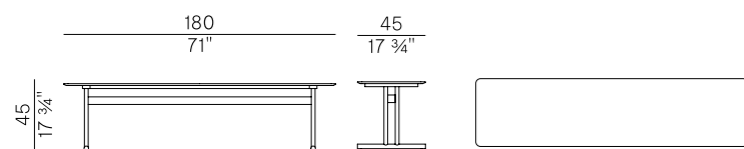

955/O-OUT

panca \ bench

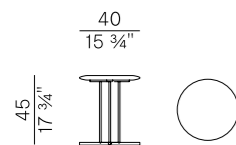

955/TBC-40-OUT

tavolino \ coffee table

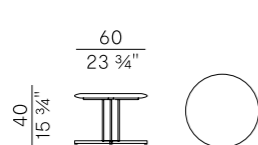

955/TBC-60-OUT

tavolino \ coffee table

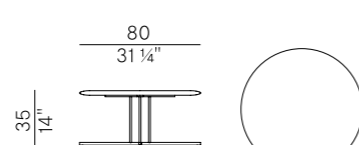

955/TBC-80-OUT

tavolino \ coffee table

FINITURE / FINISHES

BASE IN METALLO VERNICIATO
LACQUERED METAL BASE

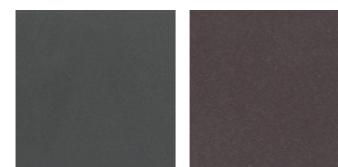

Antracite goffiato \
Anthracite embossed

Aval goffiato \
Aval embossed

PIANO IN HPL
HPL TOP

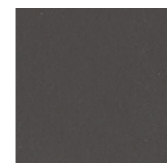

Antracite \ Anthracite

PIANO IN PIETRA (955/TBC-40-OUT, 955/TBC-60-OUT,, 955/TBC-80-OUT,)
STONE TOP

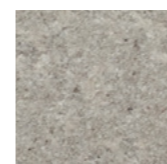

Pietra naturale light grey \
Light grey natural stone

Ola

La famiglia di sedute Ola si caratterizza per la forma dello schienale avvolgente, in tondino di metallo, che ricorda l'immagine fluida dell'onda. Declinata in sedia impilabile, poltroncina, poltroncina a pozzetto, poltrona, divano e sgabello, la famiglia si arricchisce di un nuovo elemento: il pouf, che prosegue armoniosamente il racconto della collezione, fatto di intrecci e dettagli raffinati.

Ola seat family is characterized by the shape of the embracing backrest made of metal rod, which recalls the fluid image of the wave. A new product is added to the collection, which already includes the stackable chair, small armchair, tub chair, armchair, sofa and stool: the pouf, which harmoniously continues the story of the collection, made up of weaves and refined details.



OLA

Design Radice & Orlandini

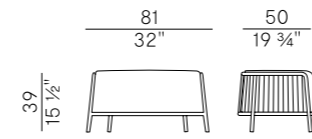

923/O

pouf \ pouf

FINITURE / FINISHES

STRUTTURA IN METALLO VERNICIATO
LACQUERED METAL FRAME

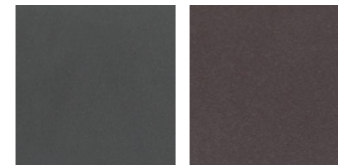

Antracite goffrato \
Anthracite embossed

Aval goffrato \
Aval embossed

INTRECCIO IN FETTUCCIA
RIBBON WEAVING



S4E

Fly grigio \
Fly grey



Credits

POTOCCO PREVIEW 2023

Art direction

— *Chiara Andreatti Studio*

Project Coordination

— *Potocco Corporate Image Team*

Photos

— *Giulio Gbirardi (p.5,6,48)*

— *Potocco Corporate Image Team*

Copy

— *CORA – Public Relations & Press Office*

Printing

— *Sincromia Srl*

Italy, April 2023

Potocco reserves the right to introduce any changes to its own models without prior notice. Color tones may vary from one dye lot to another.

© 2023 by Potocco S.p.A.
All rights reserved



The mark of
responsible forestry

*Richiedi i nostri
prodotti certificati
FSC®*

www.potocco.it



POTOCCO

Via Indipendenza 4
33044 - Manzano, Udine - Italy
T. +39 0432 745111
© 2023 Potocco S.p.A.
info@potocco.it

Potocco USA
Hickory, NC 28602
United States of America
customerservice@potocco-usa.com

