

News

Sofa

- 02 Simposio
 - 10 Vela Piping «A» & «B»
-

Armchairs & Pouf

- 18 Beauty (Armchairs & Pouf)
-

Tables & Furniture

- 22 Tres
 - 26 Butter
-

Textile Accessories & Carpets

- 31 Cime Carpet Collection

Extra Accessories

- 36 Mirror (Alphabet)
 - 41 Petits Transparents (Leyva; Rendez-vous)
-

Restyling

Sofa

- 44 Ananta
-

Armchairs & Pouf

- 52 Ola Armchair
 - 56 Fleur Armchair
-

Tables & Furniture

- 59 Ring Table
 - 63 Haiku
-

Simposio

STUDIOPEPE firma il nuovo progetto Simposio per Saba. L'ispirazione trae origine da un dialogo tra concetti da intrecciare insieme in una sintesi armonica: **forme semplici e pure scolpite in linee sinuose** ma tali da essere percepite senza tempo. Il **divano Simposio** con i suoi elementi tondi e lineari, diventa **luogo ideale di accoglienza dove conversare sul mistero della bellezza**, creando piccole o grandi arene domestiche.

Anche il piede perde la sua formale funzione e **diventa elemento distintivo** atto ad evocare la sensualità della pressione sulla stoffa. Una tappezzeria coraggiosa **ha eliminato la maggior parte delle cuciture** e solo una piega laterale definisce il profilo degli elementi, come un peplo di reminiscenza greca. I colori nero, corten e sabbia ben si adattano ai tessuti del guardaroba di Simposio e ne definiscono il carattere originale.

STUDIOPEPE designs **Simposio**, a new project for Saba. The inspiration originates from a dialogue between concepts to be intertwined together in a harmonious synthesis: **simple and pure shapes sculpted in sinuous lines**, yet to be perceived as timeless. The **Simposio sofa**, with its rounded and linear elements, becomes an **ideal place of hospitality where one can converse about the mystery of beauty**, creating small or large domestic arenas.

Even the foot structure loses its formal function and **becomes a distinctive element**, designed to evoke the sensuality of a pressure point on fabric. A bold upholstery has **eliminated most of the seams**, only a side fold defines the profile of the elements, reminiscing a Greek peplos. The colors black, corten and sand are well suited to the fabrics of Simposio's palette and define its original character.

L 406 x P 216 x H 77 cm



L 378 x P 216 x H 77 cm



L 362 x P 100 x H 77 cm







Struttura - Imbottitura

In multistrato imbottito con poliuretano espanso a quote differenziate (35IP e 25IM) per la seduta, ricoperta da una fodera in piuma. Il molleggio della seduta è assicurato da cinghie elastiche con anima in polipropilene. Lo schienale è realizzato in poliuretano espanso 25IM, ricoperto da una fodera in piuma.

Structure - Padding

In plywood padded with variable-density polyurethane foam (35IP e 25IM) for seating, covered with a feather lining. The seat is sprung with elastic straps reinforced with polypropylene. Backrest is in 25IM polyurethane foam, covered with a feather lining.

Piedini

In mdf laccati con finitura opaca.

Feet

In mdf lacquered with matt finish.

Centrali / Central units

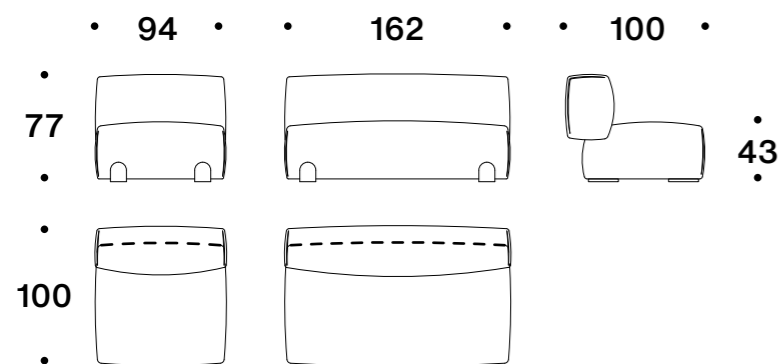

Pouf seduta / Seat pouf

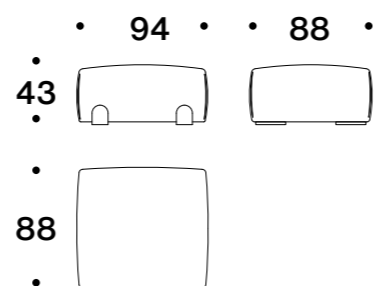

Laterali DX-SX / Right-left side units

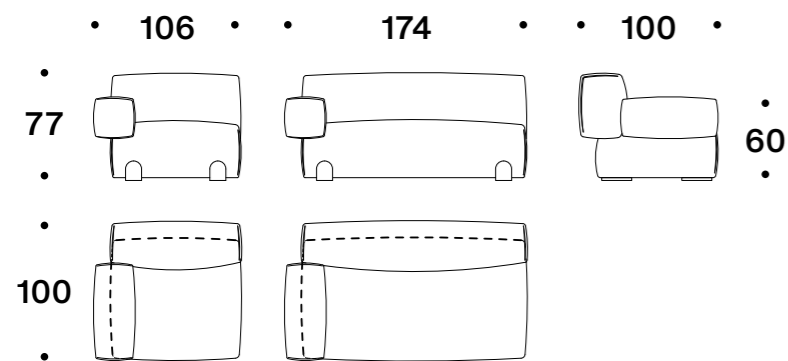

Angolare / Corner unit

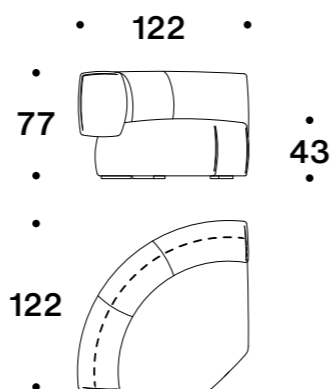

Finitura piedi - laccatura opaca / Feet finish - matt lacquering

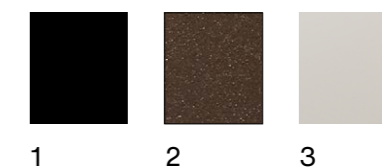

- 1 Nero / Black
- 2 Verniciato corten / Painted corten
- 3 Sabbia / Sand

Composizione 1

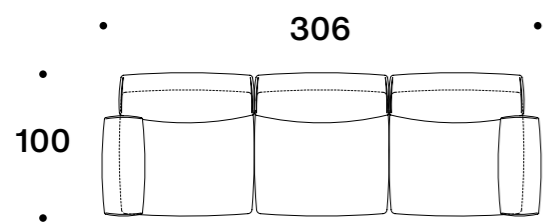

Composizione 2

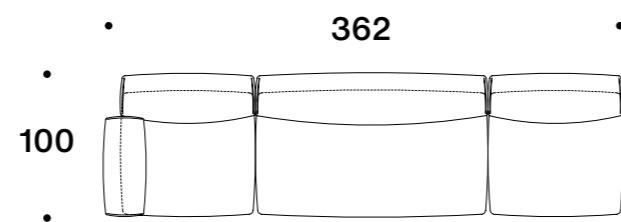

Composizione 3

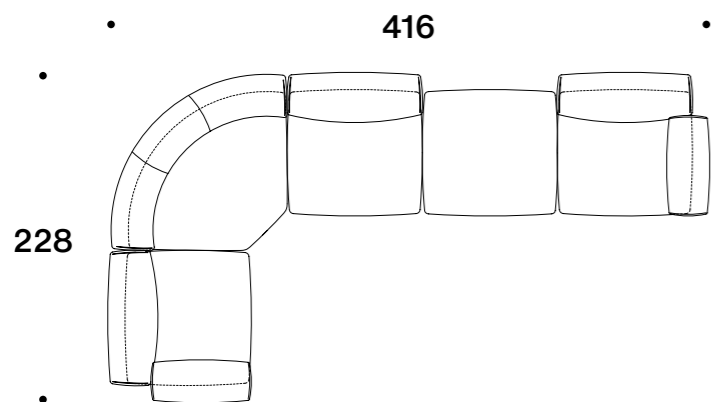

Composizione 4

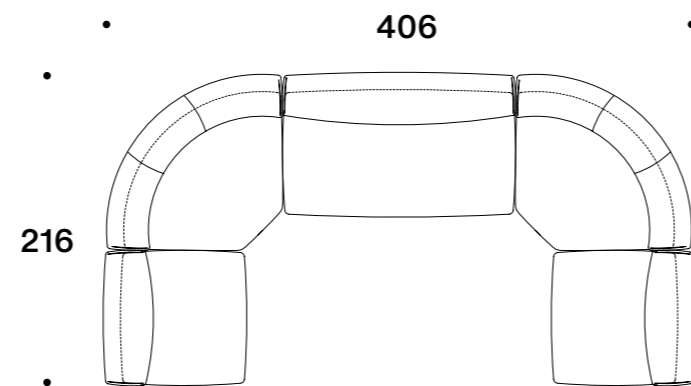

Composizione 5

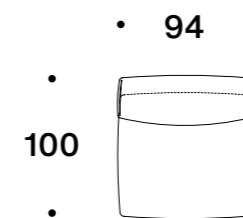

Composizione 6

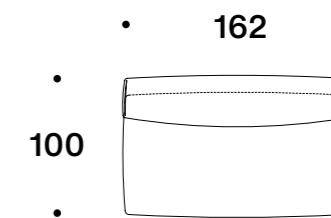

Vela Piping

Il divano **Vela Piping**, disegnato dallo studio **Zanellato/Bortotto**, è stato progettato per offrire un'esperienza di **comfort ed eleganza**. Le **generosa quantità di elementi** consente combinazioni sia classiche che inedite senza mai perdere l'armonia.

Nato dall'**ispirazione nautica** del precedente divano **Vela**, l'elemento che ora lo caratterizza si rifà alle cime delle vele e diventa un **cordolo, "piping"**, che **definisce la sagoma e ne fa accorgimento estetico**. Disponibile in due larghezze, **Vela Piping** conferma lo stile di **Saba** e il suo speciale modo di **ridisegnare la memoria** per consegnarla alla contemporaneità con un segno di **raffinata versatilità**.

The **Vela Piping** sofa, by **Zanellato/Bortotto**, has been designed to offer an experience of **comfort and elegance**. The **generous number of available elements** allows for both classic and original combinations without ever losing overall harmony.

Born from the **nautical inspiration** of the previous **Vela** sofa, the element that now characterizes it refers to the ropes of the sails and becomes a **piping detail, that defines the shape and adds subtle aesthetic character**. Available in two dimensions, **Vela Piping** confirms **Saba's** style and its special way of **redesigning memory**, placing it in contemporary design with a sign of **refined versatility**.

Saba — Vela Piping A
L 278 x P 100 x H 74 cm



Saba — Vela Piping B
L 322 x P 100 x H 74 cm
L 370 x P 100 x H 74 cm



Saba — Vela Piping A
L 278 x P 145 x H 74 cm



Saba — Vela Piping B
L 322 x P 158 x H 74 cm



L 441 x P 219 x H 74 cm



Struttura - Imbottitura

In multistrato imbottito con poliuretano espanso a quote differenziate (40IP e 25IM) per la seduta, ricoperto da un materassino in piuma rivestito con tessuto di cotone 100%. Lo schienale è realizzato in poliuretano espanso a quote differenziate (21IM e 25IM). Il tutto è rivestito con velfodera accoppiata a vellutino 150 gr/mq.

Piedini

In ABS nero h. 4 cm.

Note

Il tessuto di rivestimento esterno viene lavorato con resinato accoppiato a vellutino 200 gr/mq. Questa lavorazione implica una manutenzione della fodera con lavaggio a secco per tutti i tipi di tessuto.

Structure - Padding

In plywood padded with variable-density polyurethane foam (40IP and 25IM) for seating, covered with a feather mattress clothed with 100% cotton fabric. Backrest is made with variable-density polyurethane foam (21IM and 25IM). The whole is covered with velfodera coupled with velveteen 150 gr/sqm.

Feet

4 cm high, in black ABS.

Note

The external covering fabric is join with velfodera coupled to velveteen 200 gr/sqm. This process implies a maintenance of the cover with dry cleaning for all types of fabric.

Versione A

Laterali DX-SX / Right-left side units

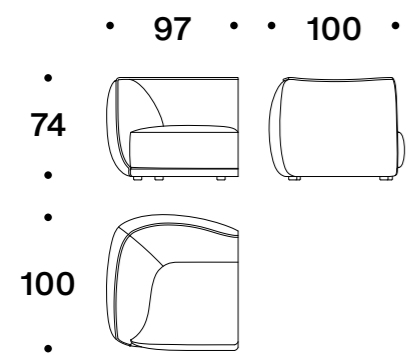

Centrale / Central unit

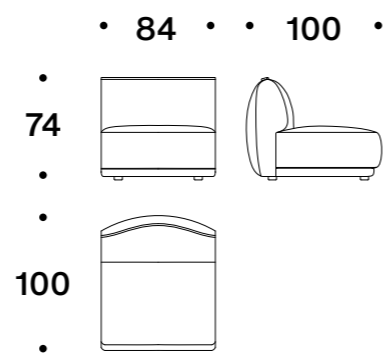

Penisole DX-SX / Right-left chaise longue

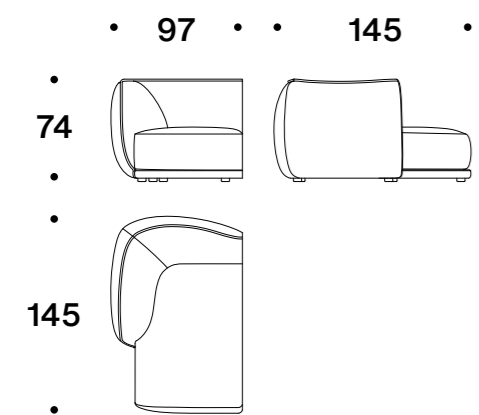

Angolare / Corner unit

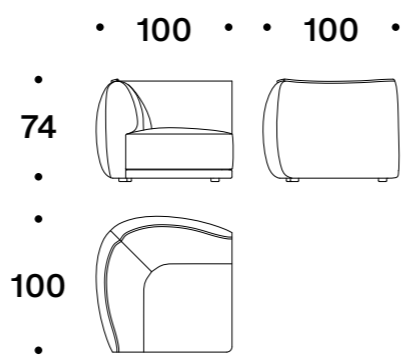

Versione B

Laterali DX-SX / Right-left side units

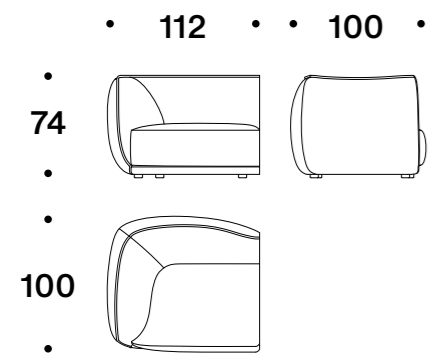

Centrale / Central unit

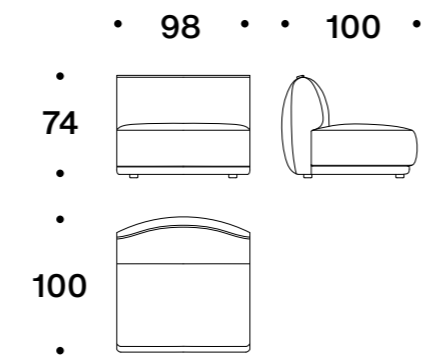

Penisole DX-SX / Right-left chaise longue

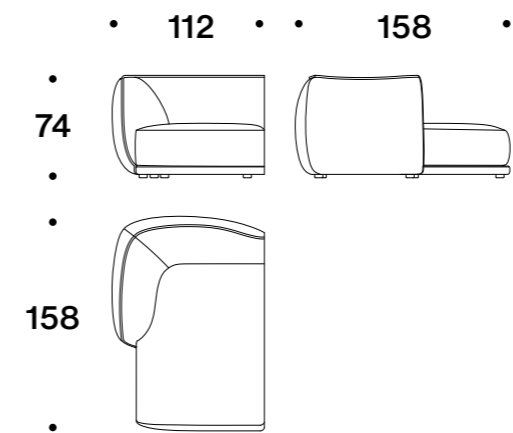

Angolare / Corner unit

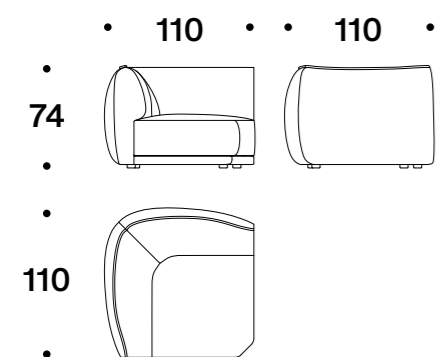

Angolare aperto / Open corner unit

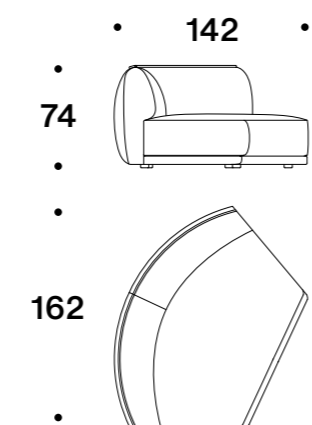

Terminali DX-SX / Right-left end units

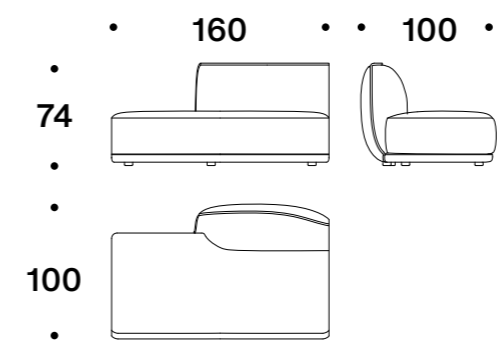

VELA PIPING A
Composizione 1

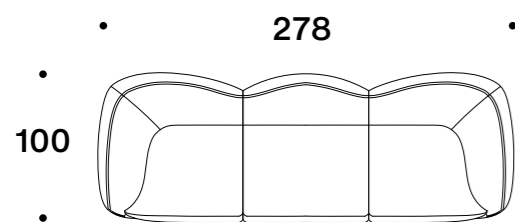

VELA PIPING A
Composizione 2

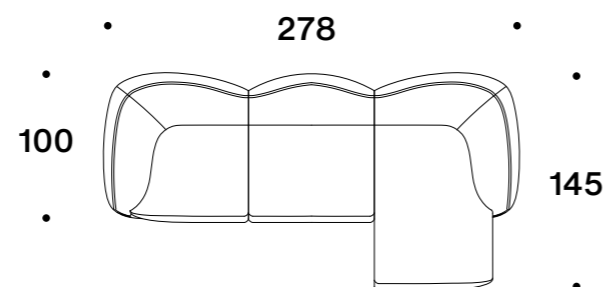

VELA PIPING B
Composizione 1

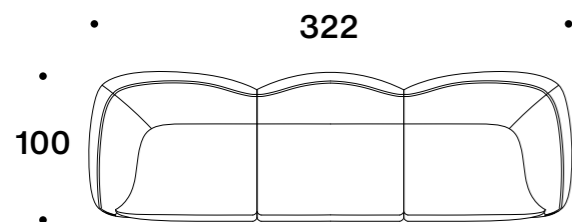

VELA PIPING B
Composizione 2

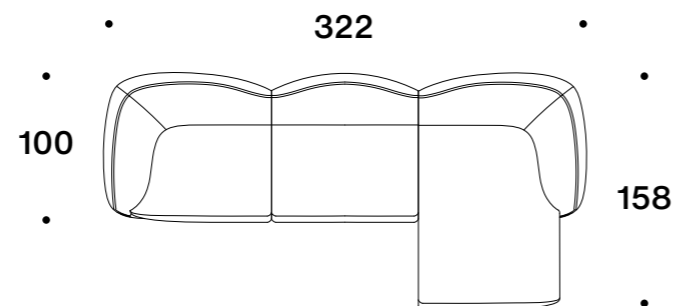

VELA PIPING B
Composizione 3

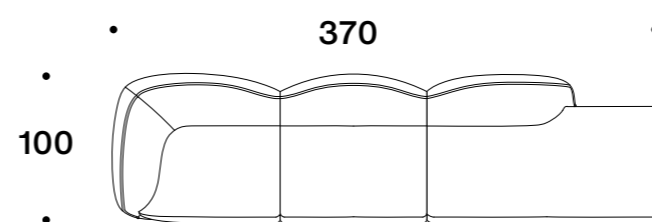

VELA PIPING B
Composizione 4

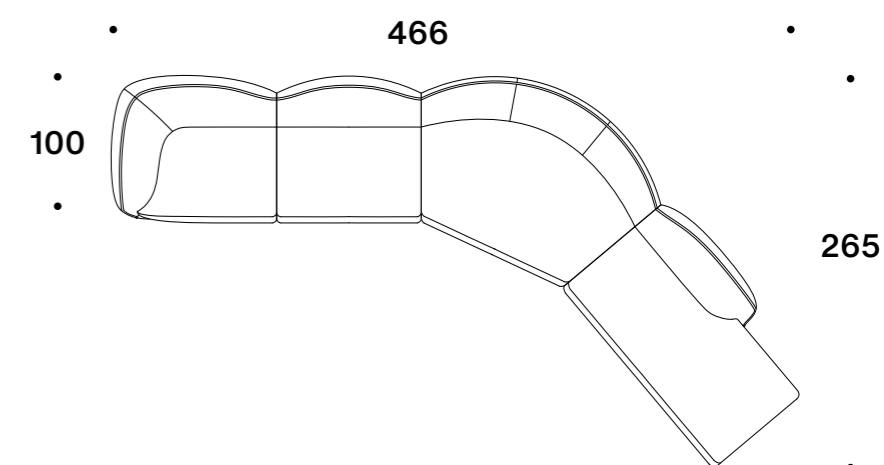

Beauty

Beauty è il nome della nuova poltroncina dedicata al gesto gentile del trucco. Femminile e ironica allo stesso tempo, è dotata di una base con movimento girevole per garantire agili posizioni.

Perfetta con Alphabet ora accessoriato di specchio, crea un angolo super ricercato e intimo. Del modello è **disponibile anche la sola seduta cilindrica da utilizzare come pouf trasversale.**

Beauty is the name of the new armchair dedicated to the gentle gesture of make-up. Feminine and ironic at the same time, it is equipped with a swivel base to ensure agile positions.

Perfect with Alphabet, now equipped with a mirror accessory, it creates a super refined and intimate corner. The **sole cylindrical seat is available to use as a transversal pouf.**

L 41 x P 49 x H 90 cm



Ø 45 x H 48 cm



Struttura - Imbottitura

In legno multistrato imbottito con poliuretano espanso a quote differenziate (25IM e 40IP), rivestito con velfodera accoppiata a vellutino 100gr/mq.

Piedini

Base e supporto schienale in metallo verniciato, spessore 10 mm.
La poltroncina è dotata di meccanismo girevole.

Structure - Padding

In plywood padded with variable-density polyurethane foam (25IM and 40IP), covered with velfodera coupled to velveteen 100gr/sqm.

Feet

Base and backrest support in 10 mm thick painted metal.
Small armchair is equipped with a swivel mechanism.

Poltroncina / Small armchair

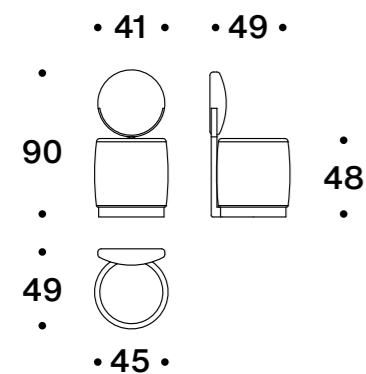

Finitura struttura - verniciatura opaca / Frame finish - matt painting

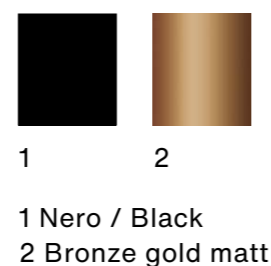

Pouf

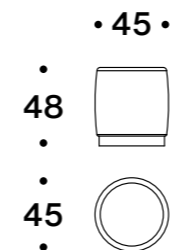

Finitura base - verniciatura opaca / Base finish - matt painting



Tres

Il coffee table **Tres** è il primo progetto che **Mut Design**, il duo creativo di Valencia, firma per Saba. La collezione è caratterizzata da **due piani triangolari arrotondati agli angoli**, distanziati da tre cilindri portanti. I volumi scultorei, proposti in due diverse dimensioni, assumono leggerezza grazie alle speciali finiture iridescenti che richiamano il madreperla delle conchiglie.

Solidità e leggerezza si fondono in una sintesi che rendono **Tres** un accessorio iconico, capace di **coniugare funzione e arte** in un solo gesto. Il nome **Tres** nasce dalla sincronicità di un incontro tra tre amici e risuona preciso nella corrispondenza dei tre angoli, nei tre cilindri e nelle tre verniciature madreperla. Disponibili nelle seguenti finiture: Opal Shell, Spring Shell e Honey Shell.

The **Tres low table** is the first project designed by **Mut Design**, creative duo from Valencia, for Saba. The collection is characterized by **two triangular surfaces with rounded edges**, distanced by three supporting cylinders. The **sculptural volumes**, available in two dimensions, acquire lightness thanks to the special **iridescent finishes** that recall the mother-of-pearl of shells.

Solidity and lightness become one in a synthesis that makes **Tres** an iconic accessory, capable of **combining function and art** into a single gesture. The name **Tres** comes from a spontaneous meeting between three friends and resonates precisely in the correspondence of the three corners, the three cylinders and the three mother- of-pearl finishes. Available in the following finishes: Opal Shell, Spring Shell e Honey Shell.

L 63 x P 57 x H 36 cm
L 40 x P 38 x H 50 cm



L 63 x P 57 x H 36 cm
L 40 x P 38 x H 50 cm



Struttura

In metallo spessore 2 mm di forma cilindrica, diametro 20 cm, agganciati su di una piastra metallica spessore 5 mm.
Finitura verniciata opaca oppure con effetto madreperla.

Top

In metallo spessore 5 mm con finitura verniciata opaca oppure con effetto madreperla.

Structure

In 2 mm thick metal with cylindric shape, diameter 20 cm, hooked on a 5 mm thick metal plate. Matt painted finish or pearl-effect pigments finish.

Top

In 5 mm thick metal with matt painted finish or with pearl-effect pigments finish.

Tavolini / Low tables

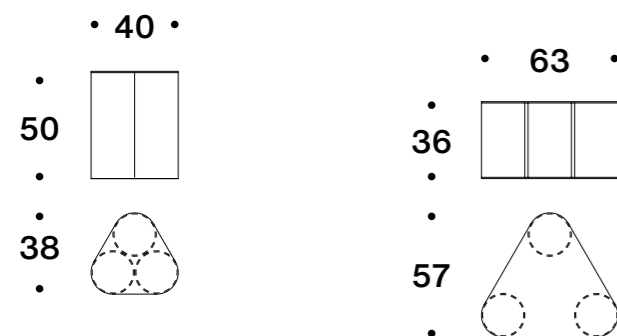

Finitura piedi-struttura / Top-frame finish

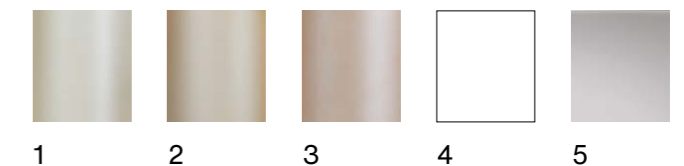

- 1 Opal Shell
- 2 Honey Shell
- 3 Spring Shell
- 4 Bianco / White
- 5 Grigio chiaro / Light grey

Butter

Evoca la lama che affonda il nuovo **tavolino Butter**. Progettato dallo studio 967arch, questa serie di elementi assolvono la loro funzione di appoggio con la **grazia delle geometrie pure**. Le forme quadrata o tonda in più dimensioni e altezze, permettono di creare **volumi disegnando lo spazio** giocando con le sfumature delle **laccature lucide o opache**.

Nella serie, anche un pratico tavolino spostabile all'occorrenza per essere collocato in prossimità di una seduta, fruibile come piano d'appoggio dove posare un libro o un oggetto. Prodotto in mdf laccato lucido o opaco, **gli elementi sono disponibili nei colori avorio e sabbia**.

The new **Butter coffee table** evokes the blade that sinks into butter. Designed by 967arch, this series of elements fulfils its function of a supporting surface with the **grace of pure geometries**. The square or round forms, available in several dimensions and heights, allow for **volumes to design the space**, by playing with the shades of the **glossy or matt finishes**.

The collection also offers a practical table that can be moved, if necessary, to be placed near a seat element, to be used as a surface to place a book or an object. Produced in glossy or matt lacquered mdf, **the elements are available in ivory and sand**.

Ø 40 x H 48 cm
Ø 50 x H 36 cm
Ø 85 x H 18 cm



L 85 x P 85 x H 18 cm
Ø 85 x H 18 cm



2 x L 85 x P 85 x H 18 cm



dati tecnici / technical data

Piedini

In metallo a sezione rettangolare 70 x 8 mm con finitura cromata o verniciata.

Feet

In rectangular section metal 70 x 8 mm with chromed or painted finish.

Top

In mdf spessore 30 mm o 80 mm con finitura laccata opaca o lucida spazzolata.

Top

In 30 mm or 80 mm thick mdf with matt lacquered or brushed glossy finish.

Tavolini - Top sottile
/ Low tables - Slim top

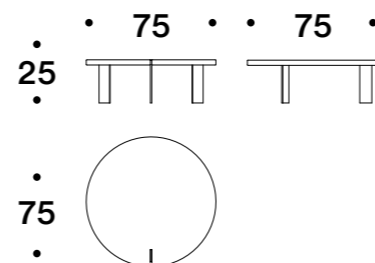
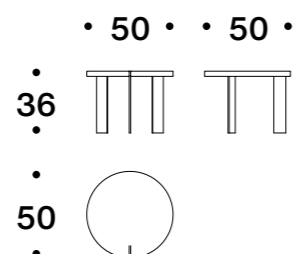
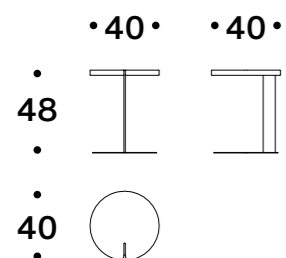

Tavolini - Top spesso
/ Low tables - Thick top

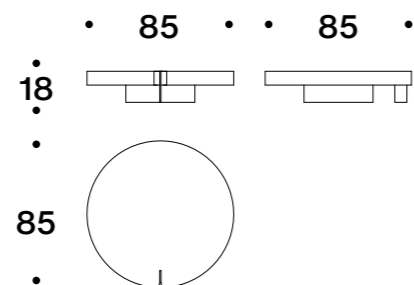
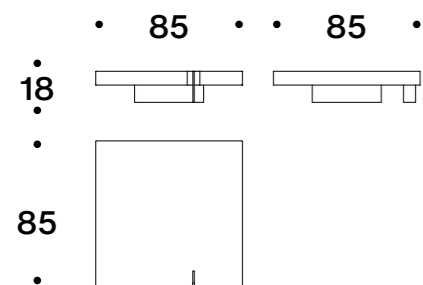

Finitura top - laccatura opaca e lucida
/ Top finish - matt and glossy lacquering

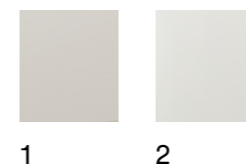

1 Sabbia / Sand
2 Avorio / Ivory

Finitura piedi-struttura
/ Top-frame finish

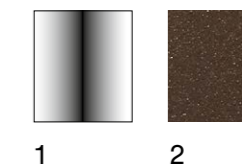

1 Black nichel / Black nickel
2 Verniciato corten / Painted corten

Cime Carpet Collection

La nuova collezione di tappeti “Cime”, nasce dal desiderio di Saba di usare la materia di cui è fatto un tappeto, quale tela per esprimere i suoi asset valoriali, ovvero la memoria e la poesia. Legare la memoria del passato, fatta di tradizioni artigianali da preservare, all'estetica contemporanea, è stato il tema affidato al duo creativo Zanellato/Bortotto, designers già attivi nella collaborazione con l'azienda. Così, come per il divano Vela, i designers hanno attinto nuovamente al mondo nautico per pensare al progetto ispirandosi alla Vela al Terzo. Caratteristica dell'Adriatico, la Vela al Terzo possedeva funzioni particolari tra cui quella di costituire un sistema di riconoscimento immediato in mare. La grafica dei tre tappeti che compongono la collezione, rimanda ai simboli e ai colori delle vele che identificavano le famiglie dei pescatori della laguna veneta, specie del polo nautico di Chioggia, ma ciò che emoziona la vista e il tatto è la tecnica antica sarda chiamata Pibiones tramandata da generazioni di donne. È stato un percorso coinvolgente di scambi stimolanti insieme al laboratorio Mariantonia Urru, una tessitura che guarda al futuro mantenendo una qualità di prodotto e di artigianato che appartiene al passato e che costituisce un grande patrimonio dal valore tecnico e culturale. Questi tappeti diventano luoghi di narrazione di storie e tradizioni e si raccontano attraverso un filo di lana “tinto in pecora” in cui la voce della natura è protagonista. La collezione comprende una grafica i cui colori sono assolutamente privi di coloranti (sono presenti due gradazioni di grigio e la tinta naturale) e una grafica disponibile in due varianti colori: tinto in pecora naturale e earth red.

The new “Cime” carpet collection stems from Saba’s desire to use the material of which a carpet is made of as a canvas to express its values, that is the concept of memory and poetry. To link the memory of the past, made of artisanal traditions to be preserved, to contemporary aesthetics, was the theme entrusted to the creative duo Zanellato/Bortotto, whose collaboration with the company had already been established. As previously done for the Vela sofa, the designers also drew on the nautical world for this project, this time inspired by lugsails. Characteristic of the Adriatic, lugsails held particular functions, including that of establishing a system of immediate recognition at sea. The graphics of the three carpets that make up the collection refer to the symbols and colors of the sails that identified fishermen families of the Venetian lagoon, especially of the Chioggia nautical center. However, what really excites visually and in a tactile form, is the ancient Sardinian technique called Pibiones, handed down by generations of women. The journey with the Mariantonia Urru laboratory has been engaging and stimulating, a weaving mill that looks to the future while maintaining a quality of product and craftsmanship that belongs to the past, constituting a great heritage of technical and cultural value. These carpets become places for narrating of stories and traditions and are told through a “sheep-dyed” wool thread, in which the voice of nature is the protagonist as these colors are created with no chemical intervention but only by mixing different amounts of the wool from white and black sheep. The collection includes a graphic whose colors are exclusively made with tonalities derived from the natural wool of sheep (there are two shades of gray and the natural dye) and a graphic available in two color variants: natural “sheep-dyed” and earth red.

L 240 x P 170 cm
L 300 x P 200 cm
L 350 x P 250 cm

Cime COLORS



L 240 x P 170 cm
L 300 x P 200 cm
L 350 x P 250 cm

Cime NATURAL



L 240 x P 170 cm
L 300 x P 200 cm
L 350 x P 250 cm

Cime EARTH RED



Materiale

20% cotone e 80% lana Sarda
(lavorazione artigianale Pibiones - made in Italy > autoestinguente
- brucia senza fiamma - certificazioni ignifughe in wip)

Material

20% cotton and 80% Sardinian wool
(artisanal Pibiones technique - Made in Italy > self-extinguishing
- can burn but without a flame - fire resistance certificate WIP)

Cime COLORS

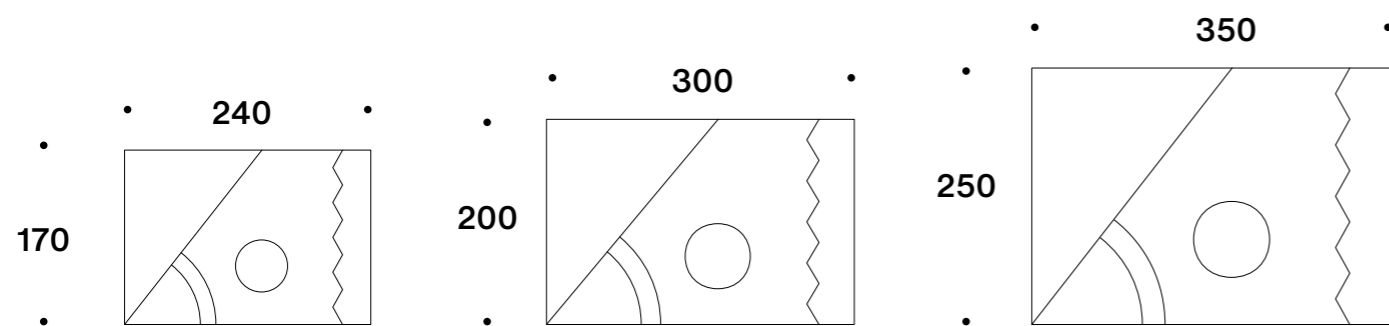

Cime NATURAL e Cime EARTH RED

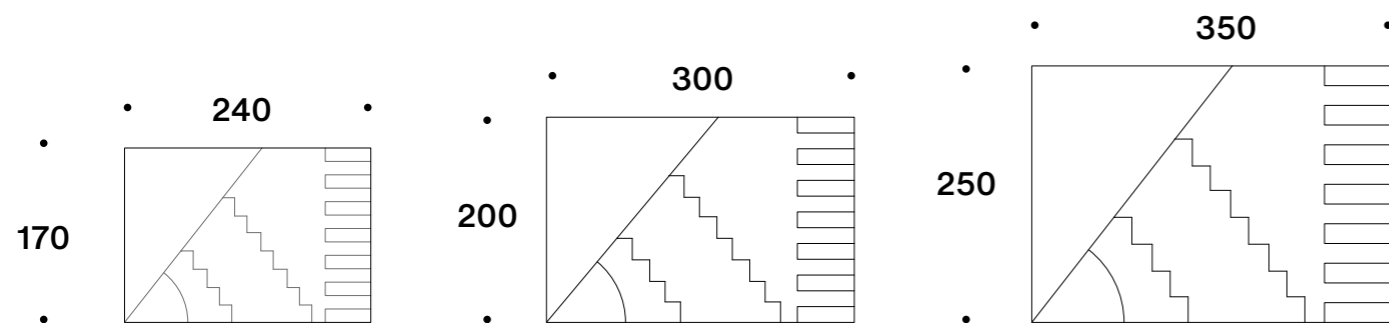

Tappeto - Lana / Carpet - Wool

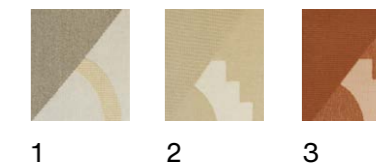

- 1 Cime colors
- 2 Cime natural
- 3 Cime earth red

Mirror (Alphabet)

Lo scrittoio **Alphabet** disegnato dallo studio **967arch**, si arricchisce dell'accessorio specchio.

Regolabile in tre altezze, lo specchio può essere integrato allo scrittoio in qualsiasi momento. Abbinato alla poltroncina **Beauty** ad esso coordinata nelle finiture e dimensioni, è un elemento d'arredo che va a completare la collezione dedicata alla zona notte.

The **Alphabet** desk, designed by **967arch**, is enriched with a mirror accessory.

Adjustable in three heights, the mirror can be integrated into the desk at any time. Combined with the **Beauty** armchair, coordinated with it in terms of finishes and dimensions, it is a piece of furniture that completes the collection dedicated to the bedroom.

L 115 x P 60 x H 121-126 cm
L 41 x P 49 x H 90 cm



L 115 x P 60 x H 121-126 cm



Struttura

In metallo verniciato.

Top

In mdf curvato, finitura laccata. Disponibile con o senza cassetto.
Quest'ultimo monta guide con rientro ammortizzato.

Specchio

Dal diametro di 41 cm e spessore 5 mm, agganciato al top attraverso un supporto metallico verniciato, regolabile a tre altezze.

Structure

In painted metal.

Top

In curved mdf, lacquered finish. Available with or without drawer.
The latter mounts guides with amortized return.

Mirror

With diameter 41 cm and thickness 5 mm, attached to the top through a painted metal support, adjustable to three heights.

Scrivania
/ Desk

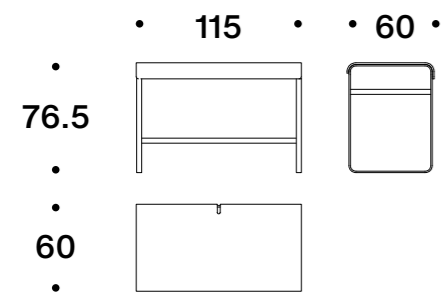

Scrivania con cassetto
/ Desk with drawer

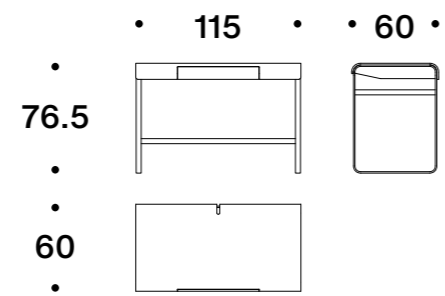

Specchio / Mirror
Optional

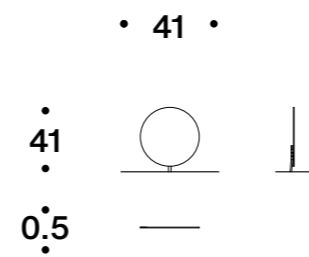

Scrivania con cassetto e specchio
/ Desk with drawer and mirror

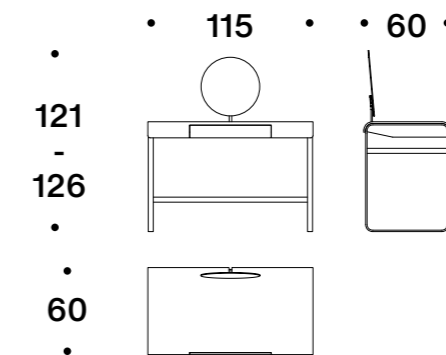

Combinazione finitura struttura opaca + top
/ Frame + top matt finish combo



Petits Transparents

Dal 2024 sono coordinabili alla collezione di tavolini Leyva e ripiani Rendez-vous i vassoi in vetro Petits Transparents disponibili in quattro formati e due finiture.

From 2024 the Petits Transparents trays, available in four sizes and two finishes, can be coordinated to Leyva low tables collection and Rendez-vous shelves.

L 25 x P 25 cm
Ø 27 cm
L 50 x P 50 cm

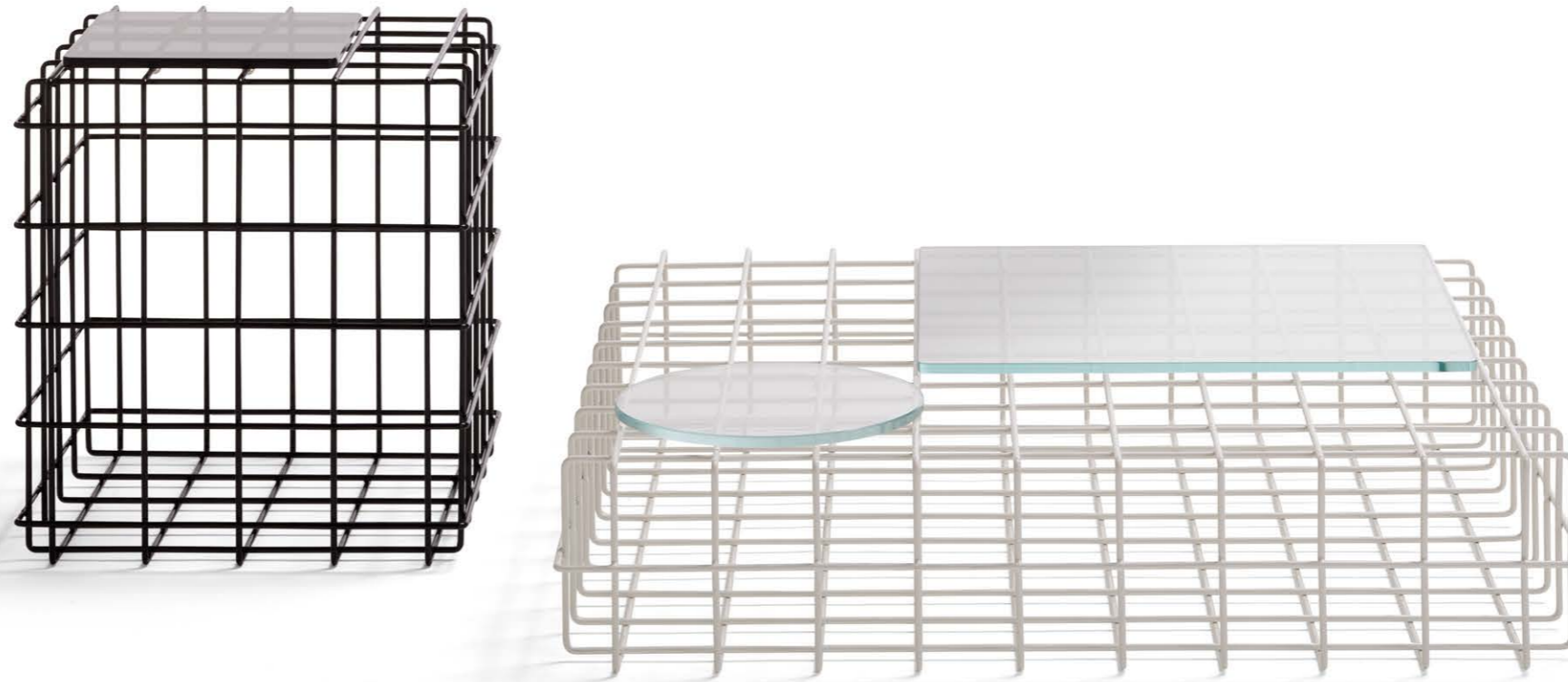

dati tecnici / technical data

Materiale

In vetro temperato spessore 10 mm.

Nota

Articolo coordinabile con Leyva tavolini e ripiani Rendez-vous.

Material

In tempered glass 10 mm thick.

Note

Coordinating article with Leyva low tables and Rendez-vous shelves.

Vassoi / Trays

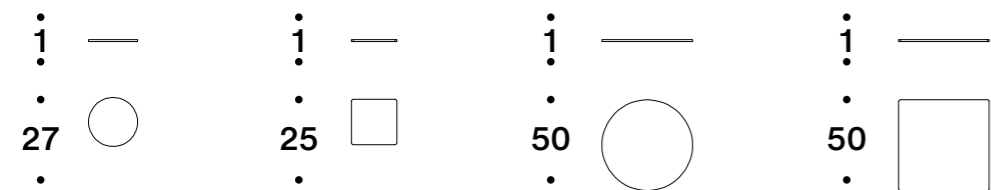

Articolo coordinabile con Rendez-vous ripiani - esempi disposizione / Coordinating article with Rendez-vous shelves - example layout

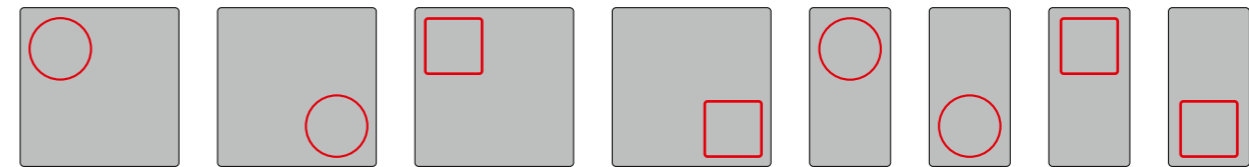

Finitura in vetro / Glass finish



1 Trasparente / Transparent
2 Fumè / Fumè

Articolo coordinabile con Leyva tavolini - esempi disposizione / Coordinating article with Leyva low tables - example layout

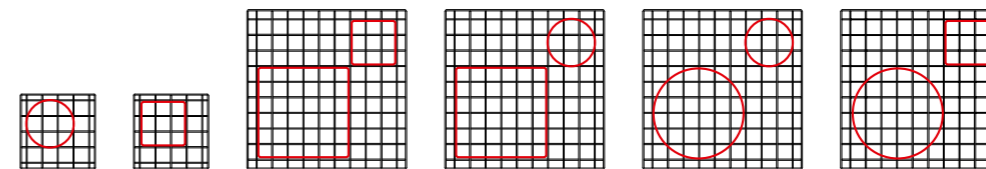

Ananta

A un ventennio dalla sua progettazione, Ananta continua a sorprendere per la sua modernità. Nato con lo scopo preciso di muoversi nello spazio in modo facile consentendo diverse configurazioni, torna ora svelando una nuova possibilità compositiva, ovvero la combinazione bifacciale degli elementi. Ananta ha anticipato il moderno concetto di fluidità ed è per questo suo valore intelligente che ce ne prendiamo cura per renderlo nel tempo sempre più coerente al moderno abitare.

Il restyling oltre a rendere possibile l'aggancio delle sedute in ogni direzione, lo ha addolcito ammorbidendo tutte le imbottiture, nuovi elementi pouf sono stati aggiunti alla già ricca modulistica e infine una nuova essenza dal colore morbido va a integrare la scelta per gli accessori tavolini. Memoria, innovazione ed eleganza fanno di Ananta un prodotto per sempre.

Twenty years after Ananta was designed it continues to surprise with its modernity. Created with the precise purpose of easily moving through space by allowing different configurations, it now unveils a new compositional possibility, the double-sided combination of elements. When conceived, Ananta anticipated the modern concept of fluidity and for this intelligent value it withholds, we care for it to be more and more consistent with the concept of modern living over time.

The restyling, in addition to making it possible to hook the seats in every direction, has mellowed it by softening all the padding. New pouf elements have been added to the already rich module options and lastly, a new soft wood finish has been integrated for the coffee table accessories. Memory, innovation and elegance make Ananta an everlasting product.

L 370 x P 340 x H 87 cm



L 370 x P 365 x H 87 cm



L 350 x P 185 x H 87 cm







Struttura

Base in legno imbottito con poliuretano espanso 30P, rivestito con velfodera accoppiata con resinato 200gr/mq. Il molleggio della seduta è assicurato da cinghie elastiche con anima in polipropilene. Gli schienali sono in legno imbottito con poliuretano espanso a quote differenziate (30P - 40IP e memory foam) ricoperti da una fodera in piuma.

Piedini

I piedini delle basi sono in ABS mentre i piedini della schiena sono in metallo con finitura cromata o verniciata.

Imbottitura

I cuscini dello schienale sono imbottiti con piuma d'oca lavata e sterilizzata suddivisa a scomparti. Ananta propone due tipi di sedute: versione piuma e versione espanso.

Versione in piuma

I cuscini della seduta sono realizzati in piuma d'oca lavata e sterilizzata suddivisa in scomparti e rivestita con tessuto di cotone bianco 100% con anima in poliuretano espanso a quote differenziate (40IP - 30IM e memory foam).

Versione in espanso

I cuscini seduta sono imbottiti in poliuretano espanso a quote differenziate (40IP e 30IM), rivestiti con vellutino accoppiato a dacron 380gr/mq.

Tavolino - struttura

In metallo con finitura corten o black nichel.

Tavolino - top

Impiallaccato noce canaletto o rovere chiaro oppure rivestito in cuoio rigenerato.

Structure

In wood padded with polyurethane foam 30P, covered with velfodera on a resin-coated backing 200gr/sqm. The seat is sprung with elastic straps reinforced with polypropylene. Backrests are in wood padded with variable-density polyurethane foam (30P - 40IP e memory foam) covered with a feather lining.

Feet

The bases have feet in ABS while the feet of the backs are in metal with chromed or painted finish.

Padding

The back cushions are padded with washed and sterilized goose down divided into sections. Ananta proposes two kinds of seats: feather and polyurethane foam versions.

Feather version

The seat cushions are filled with washed and sterilized goose down divided into sections and covered with white 100% cotton fabric with a variable-density polyurethane foam core (40IP - 30IM e memory foam).

Foam version

The seat cushions are padded with variable-density polyurethane foam (40IP e 30IM), covered with velveteen coupled with dacron 380gr/sqm.

Low table - structure

In metal with corten or black nickel finishing.

Low table - top

Canaletto walnut or light durmast veneer or covered in regenerated leather.

Basi / Bases

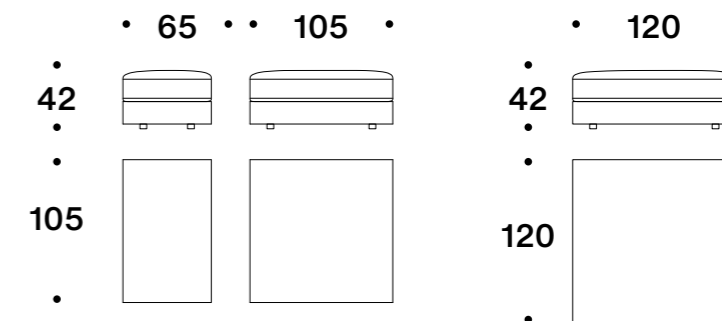
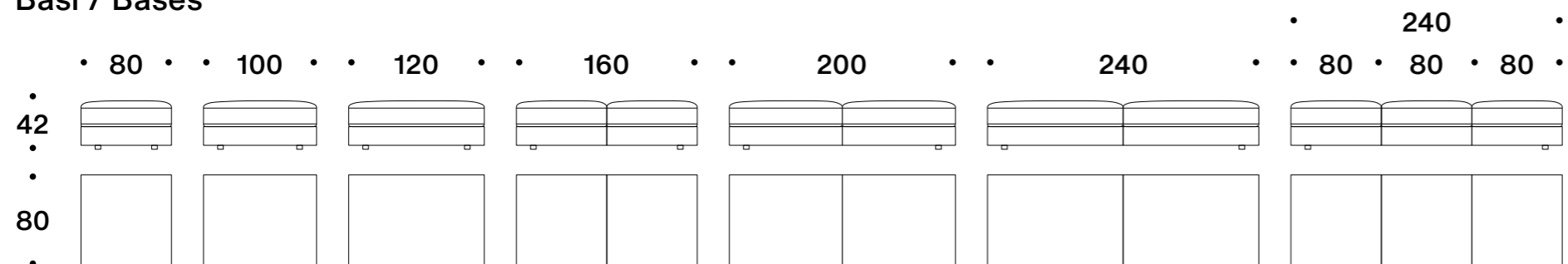

Bracciolo / Armrest

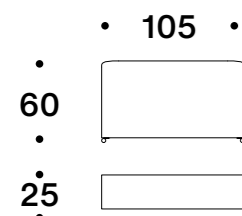

Schienali / Backrest

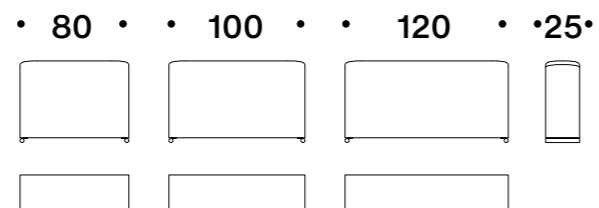

Schienali angolari / Corner backrests

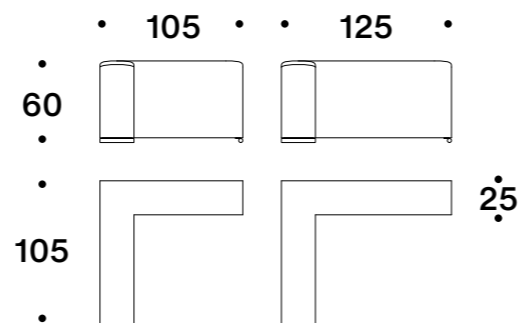

Fianco - Base con schienale / Side - Base with backrest



Tavolini / Low tables

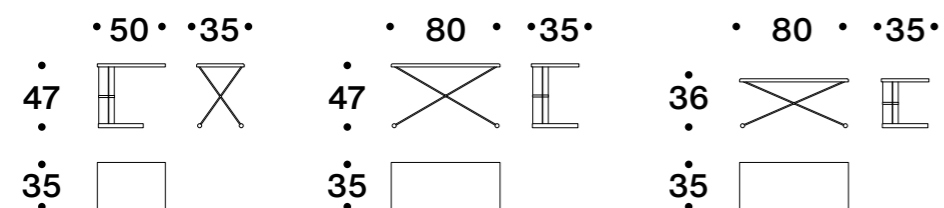

Cuscini schiena / Back cushions

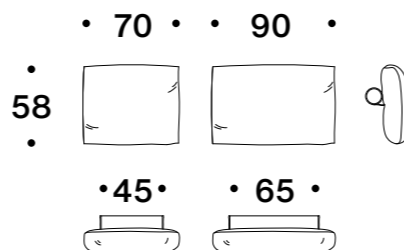

Cuscino arredo / Throw cushion

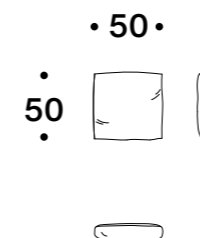

Finitura piedi schienale e struttura tavolino / Backrest feet and low table frame finish

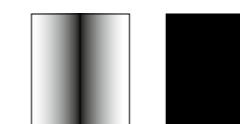

1 2

1 Black nichel / Black nickel
2 Verniciato corten / Painted corten

Ola

Ola nasce da un'idea semplice ma al tempo stesso complessa, creare una poltroncina accogliente utilizzando 4 fogli curvi indipendenti tra loro, ciascuno dei quali converge verso un unico centro rappresentato dall'individuo che la utilizza (i fogli diventano 2 per la versione senza braccioli). La struttura in metallo ha un tratto essenziale e grafico in contrasto con le rotondità della parte imbottita. Completamente sfoderabile. Dal 2024 il prodotto viene ricalibrato per garantirne un nuovo comfort.

Ola originates from a simple idea but at the same time represents a complex concept – a welcoming arm chair created utilising four individual curved sheets. Each sheet converges towards a single centre. Four sheets become two sheets for the variation without arm rests. The metal frame has an essential and graphic silhouette in contrast with the padded rounded forms. Fully removable covers. From 2024, the product has been recalibrated to ensure new comfort.

L 86 x P 80 x H 80 cm
L 75 x P 80 x H 80 cm



Struttura - Imbottitura

In legno di betulla multistrato curvato con poliuretano espanso rivestito con fibra poliestere. La seduta è realizzata con poliuretano espanso a quote differenziate (50IP - 30IM) e rivestita in fibra di poliestere 100gr/mq. Schienale e braccioli sono realizzati con poliuretano espanso 30IM e rivestiti in fibra di poliestere 100gr/mq.

Piedini

In metallo verniciato o cromato dal diametro 22 mm.

Note

Versione trapuntata: il tessuto di rivestimento esterno viene lavorato con resinato accoppiato a vellutino 150 gr/mq. Questa lavorazione implica una manutenzione della fodera con lavaggio a secco per tutti i tipi di tessuto.

Structure - Padding

In plywood curved birch with polyurethane foam covered with polyester fiber. Seating is made with variable-density polyurethane foam (50IP - 30IM) and covered with polyester fiber 100gr/sqm. Backrest and armrests are made in polyurethane foam 30IM and covered with polyester fiber 100gr/sqm.

Feet

In metal 22 mm of diameter painted or chromed finish.

Note

Quilted version: The external covering fabric is join with velfodera coupled to velveteen 150 gr/sqm. This process implies a maintenance of the cover with dry cleaning for all types of fabric.

Versione liscia / Smooth version

Versione trapuntata / Quilted version

Poltrona / Armchair

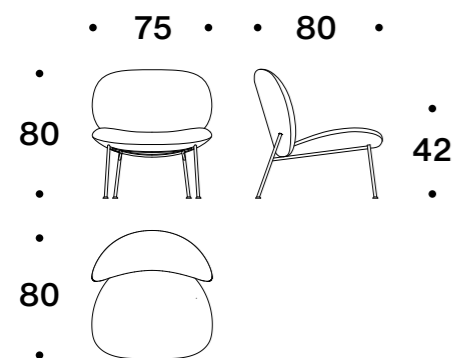

Poltrona con braccioli / Armchair with armrests

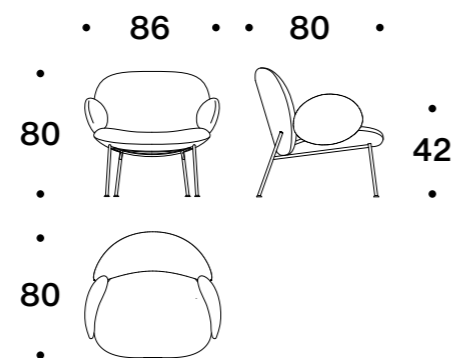

Poltrona / Armchair

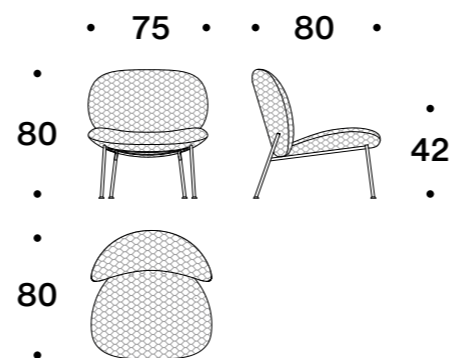

Poltrona con braccioli / Armchair with armrests

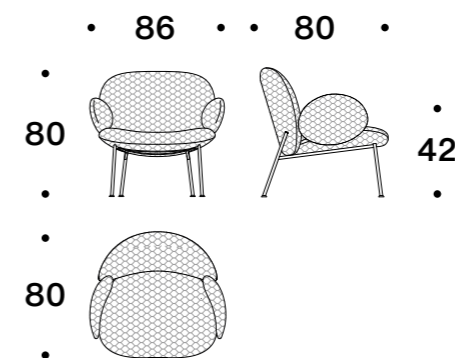

Sedia / Chair

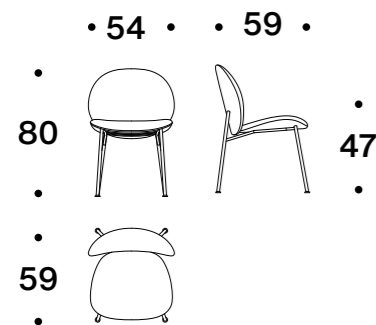

Sedia con braccioli / Chair with armrests

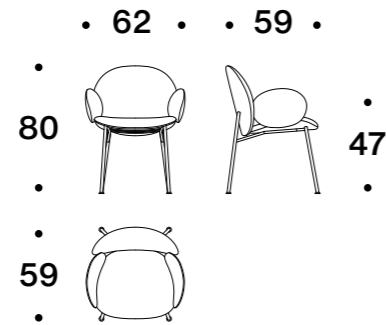

Sgabello alto / High stool

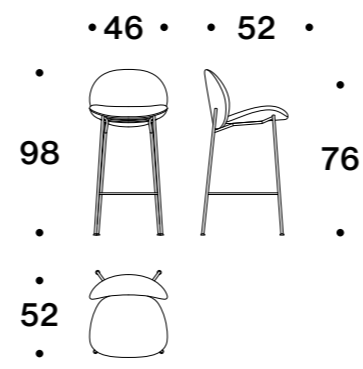

Sgabello basso / Low stool

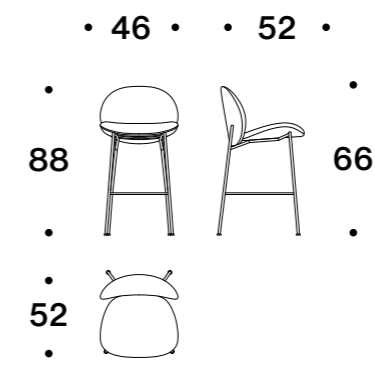

Finitura struttura / Frame finish



Fleur

La poltrona Fleur e la sedia Petite Fleur, designer Sergio Bicego, si ispirano alla grazia di un fiore e introducono la struttura cantilever all'interno della collezione di sedute e poltrone Saba. Pur rispettando la funzionalità della classica cantilever, **garantendo molleggio e flessibilità di seduta**, si distinguono per la loro **allure romantica e cocoon**. Completamente sfoderabile. Dal 2024 l'imbottitura della poltrona viene implementata per rendere il comfort più avvolgente.

The Fleur armchair and the Petite Fleur chair, designed by Sergio Bicego, are inspired by the graceful forms of a flower and introduce a cantilever structure in the Saba chair and armchair collection. Despite their traditional cantilever function, **ensuring a springy and flexible seat**, these items are distinguished for their **romantic allure and cocoon shape**. Fully removable covers. From 2024, the upholstery of the armchair has been enhanced to make the overall comfort more enveloping.

L 90 x P 76 x H 80 cm



Struttura - Imbottitura

In trafilato dal diametro di 11 mm, anima in poliuretano espanso 38IM, rivestita con poliuretano accoppiato a vellutino e ricoperto da resinato 280gr/mq accoppiato al tessuto di rivestimento. Il cuscino seduta è in poliuretano espanso a quote differenziate (43IP e memory foam) rivestito con cotone accoppiato a fibra di poliestere 380gr/mq.

Piedini

Basamento in trafilato dal diametro 25 mm con finitura cromata o verniciata.

Structure - Padding

In 11 mm wire drawn, polyurethane foam core 38IM, clothed with polyurethane coupled to velveteen and covered with 280gr/sqm resin coupled to the upholstery fabric. Seat cushion is in variable-density polyurethane foam (43IP and memory foam) clothed with cotton coupled with polyester fiber 380gr/sqm.

Feet

Base in 25 mm wire drawn with a chromed or painted finish.

**Fleur
Poltrona / Armchair**

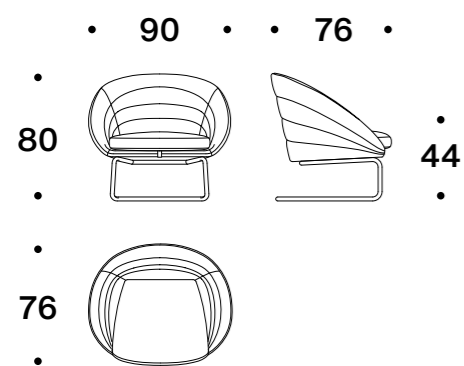

**Petite Fleur
Sedia / Chair**

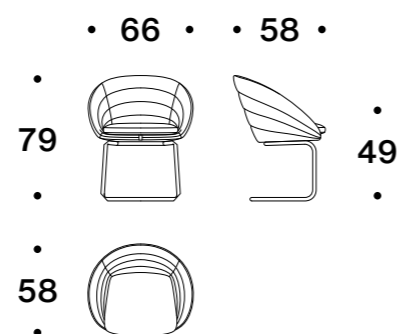

**Finitura struttura
/ Frame finish**

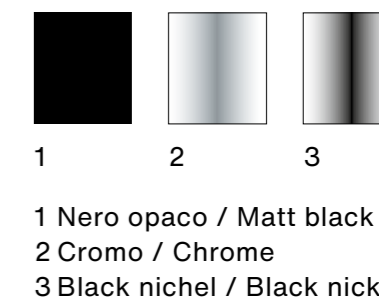

Ring Table

La collezione di tavolini Ring è stata rivisitata nelle proporzioni e finiture. Il restyling ne ha enfatizzato il carattere sofisticato, consentendo combinazioni inedite.

Eleganti come gioielli dalle cui forme traggono ispirazione, questi tavolini rendono prezioso l'ambiente e ingentiliscono anche gli arredi più semplici. I tavolini piccoli tondo e quadrato mantengono le dimensioni originali, mentre le stesse forme diventano H.35 diametro 80 per il tavolino tondo e H.30x80 nel tavolino quadrato.

The Ring coffee table collection has been revisited in its proportions and finishes. The restyling has emphasized its sophisticated character, allowing for new combinations.

Elegant like jewelry, whose shapes they draw inspiration from, these coffee tables embellish the surroundings and soften even the simplest furnishings. The small round and square coffee tables maintain their original dimensions, while the same shapes become H.35 diameter 80 for the round coffee table and H.30x80 for the square coffee table.

Ø 80 x H 35 cm
Ø 48 x H 50 cm



L 80 x P 80 x H 30 cm
L 53 x P 53 x H 45 cm



dati tecnici / technical data

Struttura

In ferro, spessore 4 mm, finitura cromata o verniciata.

Feet

In iron, 4 mm thick, chromed or painted finish.

Top

In vetro temperato spessore 8 mm.

Top

In tempered glass 8 mm thick.

Tavolini piccoli / Small low tables

Tondo / Round

Quadrato / Square

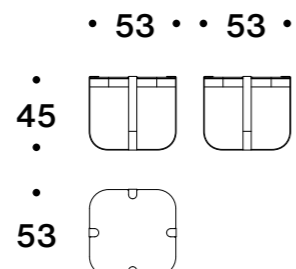
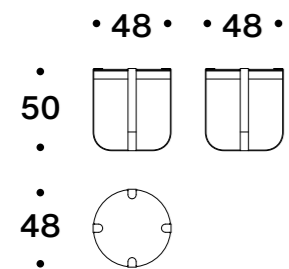

Tavolini grandi / Large low tables

Tondo / Round

Quadrato / Square

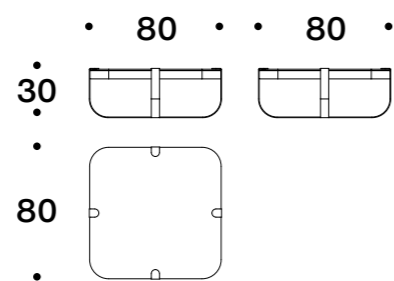
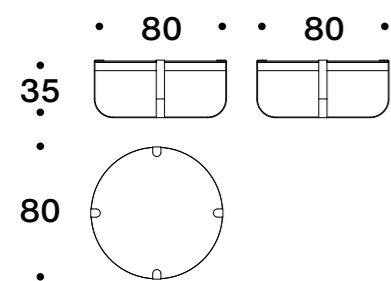

**Finitura top vetro
/ Glass top finish**



- 1 Trasparente / Transparent
2 Fumè / Fumè

**Finitura struttura
/ Frame finish**



- 1 Black nichel / Black nickel
2 Ottone satinato / Satin brass
3 Crema / Cream
4 Tortora / Dove-grey

Haiku

Haiku è il termine giapponese che descrive un componimento poetico costituito da soli tre versi per un totale di diciassette sillabe. Il coffee table firmato Marco Zito per Saba Italia si compone appunto di tre elementi: la struttura e i due piani. L'esile architettura sospende i piani su due livelli che giocano sulla parziale sovrapposizione e su accostamenti di colore dalle nuances pastello, in un semplice e misurato rapporto di equilibrio e proporzioni. Haiku è stato pensato in una palette raffinata di colori. Struttura in tondino metallico verniciato. Piani in MDF laccato. Dal 2024 il prodotto viene ricalibrato nelle sue proporzioni per garantirne la robustezza mantenendo la sua iconica leggerezza.

Haiku is a Japanese poem consisting of just three lines and a total of seventeen syllables. The coffee table designed by Marco Zito for Saba Italia is in fact made up of three parts: the frame and the two tops. The slim architecture suspends the tops on two levels which play with the partial overlap of colors, in a simple and well-gauged relationship of balance and proportions. Haiku was designed with a sophisticated color palette. Frame in painted metal rod. Top in lacquered MDF. From 2024, the product has been recalibrated in its proportions to ensure its robustness while maintaining its iconic lightness.

L 71 x P 36 x H 41 cm
L 71 x P 71 x H 31 cm



dati tecnici / technical data

Struttura

In trafilato verniciato opaco diametro 14 mm.

Top

Piano in MDF laccato opaco h 16 mm.

Structure

In matt painted wire drawn with diameter 14 mm.

Top

In matte lacquered finish MDF h 16 mm.

Tavolini / Low tables

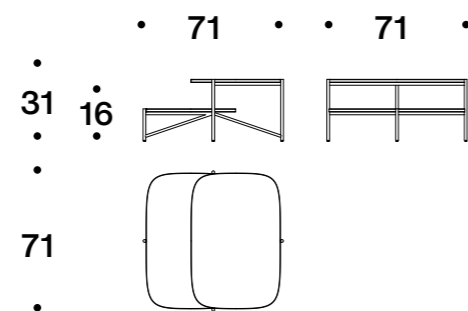
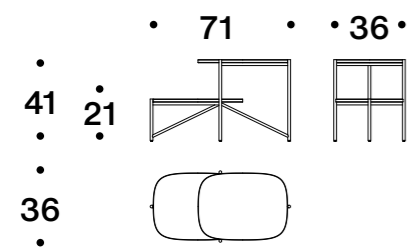

**Finitura struttura
/ Frame finish**



- 1
 - 2
- 1 Nero opaco / Matt black
2 Ottone satinato / Satin brass

**Finitura opaca piani
/ Tops matt finish**



- 1
- 1 Nero / Black

**Finitura struttura
/ Frame finish**



- 1
- 1 Nero opaco / Matt black

**Finitura opaca piani
/ Tops matt finish**



- 1
 - 2
 - 3
- 1 Cipria / Mud cream
2 Verde lichene / Moss green
3 Grigio / Grey

